

# **FURUNO**

## **OPERATOR'S MANUAL**

### *SATELLITE COMPASS*

**SC-70**

Model

**SC-130**

---

**ECF**

(Elemental Chlorine Free)

The paper used in this manual  
is elemental chlorine free.

**FURUNO ELECTRIC CO., LTD.**

9-52 Ashihara-cho,  
Nishinomiya, 662-8580, JAPAN

• FURUNO Authorized Distributor/Dealer

All rights reserved. Printed in Japan

Pub. No. OME-72820-F

(AKMU) SC-70/SC-130

A : JAN. 2017

F : APR. 10, 2018



0 0 0 1 9 2 4 0 7 1 5

# IMPORTANT NOTICES

## General

- This manual has been authored with simplified grammar, to meet the needs of international users.
- The operator of this equipment must read and follow the descriptions in this manual. Wrong operation or maintenance can cancel the warranty or cause injury.
- Do not copy any part of this manual without written permission from FURUNO.
- If this manual is lost or worn, contact your dealer about replacement.
- The contents of this manual and equipment specifications can change without notice.
- The example screens (or illustrations) shown in this manual can be different from the screens you see on your display. The screens you see depend on your system configuration and equipment settings.
- Save this manual for future reference.
- Any modification of the equipment (including software) by persons not authorized by FURUNO will cancel the warranty.
- The following concern acts as our importer in Europe, as defined in DECISION No 768/2008/EC.
  - Name: FURUNO EUROPE B.V.
  - Address: Ridderhaven 19B, 2984 BT Ridderkerk, The Netherlands
- All brand and product names are trademarks, registered trademarks or service marks of their respective holders.

## How to discard this product

Discard this product according to local regulations for the disposal of industrial waste. For disposal in the USA, see the homepage of the Electronics Industries Alliance (<http://www.eiae.org/>) for the correct method of disposal.

## How to discard a used battery

Some FURUNO products have a battery(ies). To see if your product has a battery, see the chapter on Maintenance. Follow the instructions below if a battery is used. Tape the + and - terminals of battery before disposal to prevent fire, heat generation caused by short circuit.

### In the European Union

The crossed-out trash can symbol indicates that all types of batteries must not be discarded in standard trash, or at a trash site. Take the used batteries to a battery collection site according to your national legislation and the Batteries Directive 2006/66/EU.

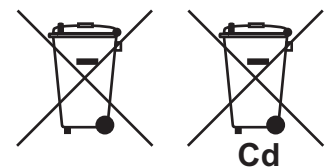

### In the USA

The Mobius loop symbol (three chasing arrows) indicates that Ni-Cd and lead-acid rechargeable batteries must be recycled. Take the used batteries to a battery collection site according to local laws.

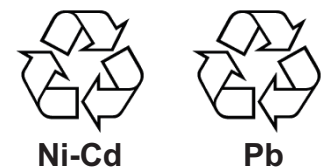

### In the other countries

There are no international standards for the battery recycle symbol. The number of symbols can increase when the other countries make their own recycle symbols in the future.



# SAFETY INSTRUCTIONS

The operator and installer must read the applicable safety instructions before attempting to operate or install the equipment. Failure to comply with these safety instruction may cause injury, loss of life or damage to the equipment.

<b>DANGER</b>	Indicates a potentially hazardous situation which, if not avoided, will result in death or serious injury.
<b>WARNING</b>	Indicates a potentially hazardous situation which, if not avoided, could result in death or serious injury.
<b>CAUTION</b>	Indicates a potentially hazardous situation which, if not avoided, can result in minor or moderate injury.





Warning, Caution	Prohibitive Action	Mandatory Action
------------------	--------------------	------------------

### Safety instructions for the installer

<b>WARNING</b>
<b>Turn off the power at the mains switchboard before beginning the installation.</b> Fire, electrical shock or serious injury can result if the power is left on or is applied while the equipment is being installed.
<b>ELECTRICAL SHOCK HAZARD</b> <b>Do not open the equipment unless totally familiar with electrical circuits and service manual.</b> Only qualified personnel should work inside the equipment.
<b>Use the specified power cable.</b> Fire can result if an incorrect cable is used.
<b>Do not disassemble or modify the equipment.</b> Fire, electrical shock or serious injury can occur.
<b>Do not install the equipment where it may get wet from rain or water splash.</b> Water in the equipment can cause fire, electrical shock or damage to the equipment.

<b>CAUTION</b>		
	<b>Ground the equipment to prevent electrical shock and mutual interference.</b>	
	<b>Observe the following safe compass distances to prevent interference to a magnetic compass:</b>	
	Standard compass	Steering compass
Display Unit SC-702	0.50 m	0.30 m
Junction Box SC-701	1.35 m	0.85 m
Antenna Unit SC-703	0.40 m	0.30 m
Antenna Unit SC-1303	0.30 m	0.30 m
Remote Display Unit RD-50	0.45 m	0.30 m
Remote Display Unit RD-20	1.25 m	0.80 m

***Safety instructions for the operator***

 <b>WARNING</b>	
	<b>ELECTRICAL SHOCK HAZARD</b> Do not open the equipment unless totally familiar with electrical circuits and service manual.  Only qualified personnel should work inside the equipment.
	<b>Do not disassemble or modify the equipment.</b>  Fire, electrical shock or serious injury can occur.
	<b>Turn off the power immediately if water leaks into the equipment or smoke or fire is coming from the equipment.</b>  Failure to turn off the equipment can cause fire or electrical shock. Contact a FURUNO agent for service.
	<b>Use the correct fuse.</b>  A wrong fuse can cause fire or serious damage to the equipment.

<b>CAUTION</b>	
	<b>No single navigation aid (including this unit) should ever be relied upon as the exclusive means for navigating your vessel.</b>  The navigator is responsible for checking all aids available to confirm his position. Electronic aids are intended to assist, not replace, the navigator.

**WARNING LABEL**

A warning label is attached to the Junction Box (SC-701). Do not remove the label.

If the label is missing or damaged, contact a FURUNO agent or dealer about replacement.

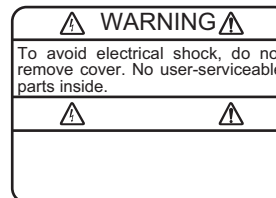

Unit: Junction Box (SC701)  
Name: Warning Label (1)  
Type: 86-003-1011-3  
CodeNo.: 100-263-233-10

**About the TFT LCD**

The TFT LCD is constructed using the latest LCD techniques, and displays 99.99% of its pixels. The remaining 0.01% of the pixels may drop out or blink, however this is not an indication of malfunction.

# TABLE OF CONTENTS

---

<b>FOREWORD</b> .....	<b>vii</b>
<b>SYSTEM CONFIGURATION</b> .....	<b>ix</b>
<b>EQUIPMENT LIST</b> .....	<b>x</b>
<b>1. INSTALLATION</b> .....	<b>1-1</b>
1.1 How to Install the Antenna Units .....	1-1
1.1.1 How to install the SC-703 Antenna Unit .....	1-3
1.1.2 How to install the SC-1303 Antenna Unit .....	1-5
1.1.3 How to retrofit from SC-603/SC-1203 .....	1-6
1.2 How to Install the Junction Box (SC-701) .....	1-7
1.3 How to Install the Display Unit (SC-702) .....	1-8
1.3.1 How to install the SC-702 on a desktop or overhead .....	1-8
1.3.2 How to flush mount the SC-702 .....	1-9
1.4 How to Install the Remote Display Unit (option) .....	1-10
1.5 Wiring .....	1-11
1.5.1 How to fabricate the cables .....	1-12
1.5.2 How to secure and waterproof the cable connections .....	1-14
1.5.3 How to fabricate the WAGO connectors .....	1-15
1.5.4 How to connect the Antenna Unit (SC-703/SC-1303) .....	1-15
1.5.5 How to connect the Junction Box (SC-701) .....	1-17
1.5.6 How to connect the Display unit (SC-702) .....	1-20
1.5.7 How to connect the Remote Display Unit (option) .....	1-23
1.6 Initial Settings .....	1-24
1.6.1 Main menu .....	1-25
1.6.2 How to set vessel dimensions, antenna location and CCRP .....	1-26
1.6.3 How to apply offsets for heading/pitch/heave/roll/position .....	1-27
1.7 How to Access and Use the [SERVICE] Menu .....	1-28
1.8 I/O Menu Settings .....	1-28
1.9 Initial Settings for the Remote Display .....	1-28
<b>2. OPERATION</b> .....	<b>2-1</b>
2.1 Controls Overview .....	2-1
2.2 How to Turn the Power On/Off .....	2-2
2.3 How to Adjust the Brilliance, Change the Background Color .....	2-3
2.3.1 How to adjust the screen and key panel brilliance .....	2-3
2.3.2 How to change the background and text color .....	2-3
2.4 Menu Overview .....	2-4
2.5 LIST Screens Overview .....	2-5
2.6 Display Modes Overview .....	2-5
2.6.1 Icons and indications .....	2-6
2.7 GPS Display Mode .....	2-7
2.7.1 GPS coordinates screen (main screen) .....	2-7
2.7.2 GPS integrity screen .....	2-8
2.7.3 BEACON INFO/TYPE 16 MESSAGE screen .....	2-9
2.8 THD Display Mode .....	2-10
2.8.1 HDG data screen .....	2-10
2.8.2 ROT data screen .....	2-11
2.8.3 HDG/ROT split screen .....	2-11
2.8.4 THD integrity screen .....	2-12
2.9 ROTI Display Mode .....	2-13
2.9.1 ROTI Display for RD-50/RD-20 (option) .....	2-13

2.10	SPD Display Mode (Non-IMO types only)	2-14
2.10.1	Speed and distance display screen	2-14
2.10.2	Navigational data screen	2-15
2.11	Alerts	2-15
2.11.1	How to acknowledge alerts	2-16
2.11.2	How to enable/disable the aural alert (Non-IMO type only)	2-16
2.11.3	How to access the alert list	2-17
2.11.4	How to access the alert log	2-18
2.12	How to View the Connected Devices	2-19
2.13	DISPLAY Menu	2-20
2.13.1	How To Change the Display Color	2-20
2.13.2	How to Change the Units of Measurement	2-20
2.13.3	How To Use The Smoothing Menu	2-21
2.13.4	How to set the number of digits after a decimal point	2-21
2.13.5	How to Set Geodetic Data	2-22
2.13.6	How to Reset the Trip Meter	2-22
2.13.7	How to Adjust the Date and Time	2-22
2.13.8	How to Set the Display Language	2-23
2.14	GNSS Menu	2-23
2.14.1	How to select the positioning system to use	2-23
2.14.2	How to set the positioning conditions	2-24
2.14.3	How to Set Up DGPS/SBAS	2-25
2.14.4	How to Set Up RAIM	2-26
2.14.5	How to set the rollover timing	2-26
2.15	How to Set Up the I/O Menu	2-27
2.15.1	How to set up serial data output	2-27
2.15.2	How to set up LAN data output	2-28
2.15.3	How to set up data sources (data input)	2-29
2.15.4	How to use the input/output logs	2-30
2.15.5	How to restart heading output	2-32
2.15.6	How to change the speed reference (Non-IMO types only)	2-33
2.16	SENSOR Menu	2-33
2.16.1	OTHER menu	2-33
2.16.2	SENSOR STATUS menu	2-34
2.17	SYSTEM Menu	2-34
2.17.1	Simulation mode	2-35
2.17.2	SYSTEM SOUND menu	2-37
2.17.3	SYSTEM LOG menu	2-37
2.17.4	How to save a sensor log	2-38
2.17.5	How to clear display settings and GPS memory	2-38
2.18	ROTI Display Operations (RD-50/RD-20, option)	2-38
<b>3.</b>	<b>MAINTENANCE, TROUBLESHOOTING</b>	<b>3-1</b>
3.1	Preventative Maintenance	3-1
3.2	Replacement of Fuse	3-1
3.3	Basic Troubleshooting	3-2
3.4	Maintenance Menu	3-3
3.4.1	How to find unit information	3-3
3.4.2	How to Backup User Settings	3-3
3.5	Diagnostic Tests	3-5
3.5.1	Memory test	3-5
3.5.2	Keyboard test	3-6
3.5.3	LCD test	3-6
3.5.4	Automatic Test	3-7
3.5.5	Sound test	3-7

TABLE OF CONTENTS

<b>APPENDIX 1 MENU TREE .....</b>	<b>AP-1</b>
<b>APPENDIX 2 ALERT LIST.....</b>	<b>AP-4</b>
<b>APPENDIX 3 ABBREVIATIONS AND UNITS .....</b>	<b>AP-6</b>
<b>APPENDIX 4 ICONS AND SYMBOLS.....</b>	<b>AP-8</b>
<b>APPENDIX 5 GEODETIC CHART CODES .....</b>	<b>AP-9</b>
<b>APPENDIX 6 WHAT IS SBAS? .....</b>	<b>AP-10</b>
<b>APPENDIX 7 DIGITAL INTERFACE (IEC 61162-1 EDITION 4(2010-11)).....</b>	<b>AP-11</b>
<b>APPENDIX 8 PARTS LIST/LOCATION.....</b>	<b>AP-23</b>
<b>APPENDIX 9 JIS CABLE GUIDE .....</b>	<b>AP-26</b>
<b>SPECIFICATIONS .....</b>	<b>SP-1</b>
<b>PACKING LISTS.....</b>	<b>A-1</b>
<b>OUTLINE DRAWINGS.....</b>	<b>D-1</b>
<b>INTERCONNECTION DIAGRAMS .....</b>	<b>S-1</b>
<b>INDEX.....</b>	<b>IN-1</b>



# FOREWORD

---

## A Word to the Owner of the SC-70/SC-130

FURUNO Electric Company thanks you for purchasing the FURUNO SC-70 or SC-130 Satellite Compass™. We are confident you will discover why the FURUNO name has become synonymous with quality and reliability.

Since 1948, FURUNO Electric Company has enjoyed an enviable reputation for quality and reliability throughout the world. This dedication to excellence is furthered by our extensive global network of agents and dealers.

Your equipment is designed and constructed to meet the rigorous demands of the marine environment. However, no machine can perform its intended function unless properly operated and maintained. Please carefully read and follow the operation and maintenance procedures in this manual.

We would appreciate feedback from you, the end-user, about whether we are achieving our purposes.

Thank you for considering and purchasing FURUNO.

## Features

The SC-70/SC-130 is a new Satellite Compass™ designed with FURUNO advanced GPS kinematic technology. This compass has a wide range of applications for both land and sea vessels.

The main features are:

- Meets the requirement for the following regulations: IMO MSC. 116(73), ISO 22090 Ed 2.0, IMO A. 694(17), IEC 60945, ISO 22090 Ed 2.0, IEC 61108-1 Ed 2.0, ISO 20672 Ed 1.0, IEC 61924-2 Ed 1.0, IEC 61162-1 Ed 4.0, IEC 61162-2 Ed 1.0, IEC 61162-450 Ed 1.0, IEC 62288 Ed 2.0, IEC 61924-2 Ed 1.0 RESOLUTION MSC. 302(87).
- Can output speed for any set location, allowing monitoring of bow and stern berthing speeds without the use of optional equipment.
- Perfect for use as a heading sensor for RADAR/ARPA, AIS, ECDIS and scanning SONARs.
- There are no mechanical parts such as gimbals or a rotating motor, thus the compass is free from routine maintenance.
- Geomagnetism does not affect the compass performance, making it usable on any vessel.
- No need for speed correction, unlike a gyrocompass.
- Short setting time
- Easily integrated into existing ship-board network via Ethernet.
- Remote Maintenance Service (RMS) ready, allowing hassle-free assistance when in port.
- Can be connected using existing antenna cabling (SC-50/60/110/120 only) by adding the optional conversion kit. Note that existing antennas units must be replaced. (Non-IMO type only)
- Uses multiple satellite types, eliminating the problem of not having enough satellites visible. (Non-IMO type only.)

## Software used in this product

This product includes software to be licensed under the GNU General Public License (GPL) version 2.0, GNU Lesser General Public Software License (LGPL) version 2.0, Apache, BSD and others. The program(s) is/are free software(s), and you can copy it and/or redistribute it and/or modify it under the terms of the GPL version 2.0 or LGPL version 2.0 as published by the Free Software Foundation. Please access to the following URL if you need source codes:

[https://www.furuno.co.jp/en/contact/cnt\\_oss\\_e01.html](https://www.furuno.co.jp/en/contact/cnt_oss_e01.html)

## CE declaration

With regards to CE declarations, please refer to our website ([www.furuno.com](http://www.furuno.com)), for further information about RoHS conformity declarations.

## Program numbers

Unit & PC Board	PCB/Application	Program No.*
Antenna Unit	MAIN	2051570-01.xx
	GNSS	48505230xx
Junction box	MAIN	2051562-01.xx
Display Unit	MAIN	2051566-01.xx
Remote Display Unit RD-50	Starter	2651006-01.xx
	Booter	2651007-01.xx
	Main	2651008-01.xx
Remote Display Unit RD-20	Starter	2651003-01.xx
	Booter	2651004-01.xx
	Main	2651005-01.xx

\*: "xx" denotes version number.

# SYSTEM CONFIGURATION

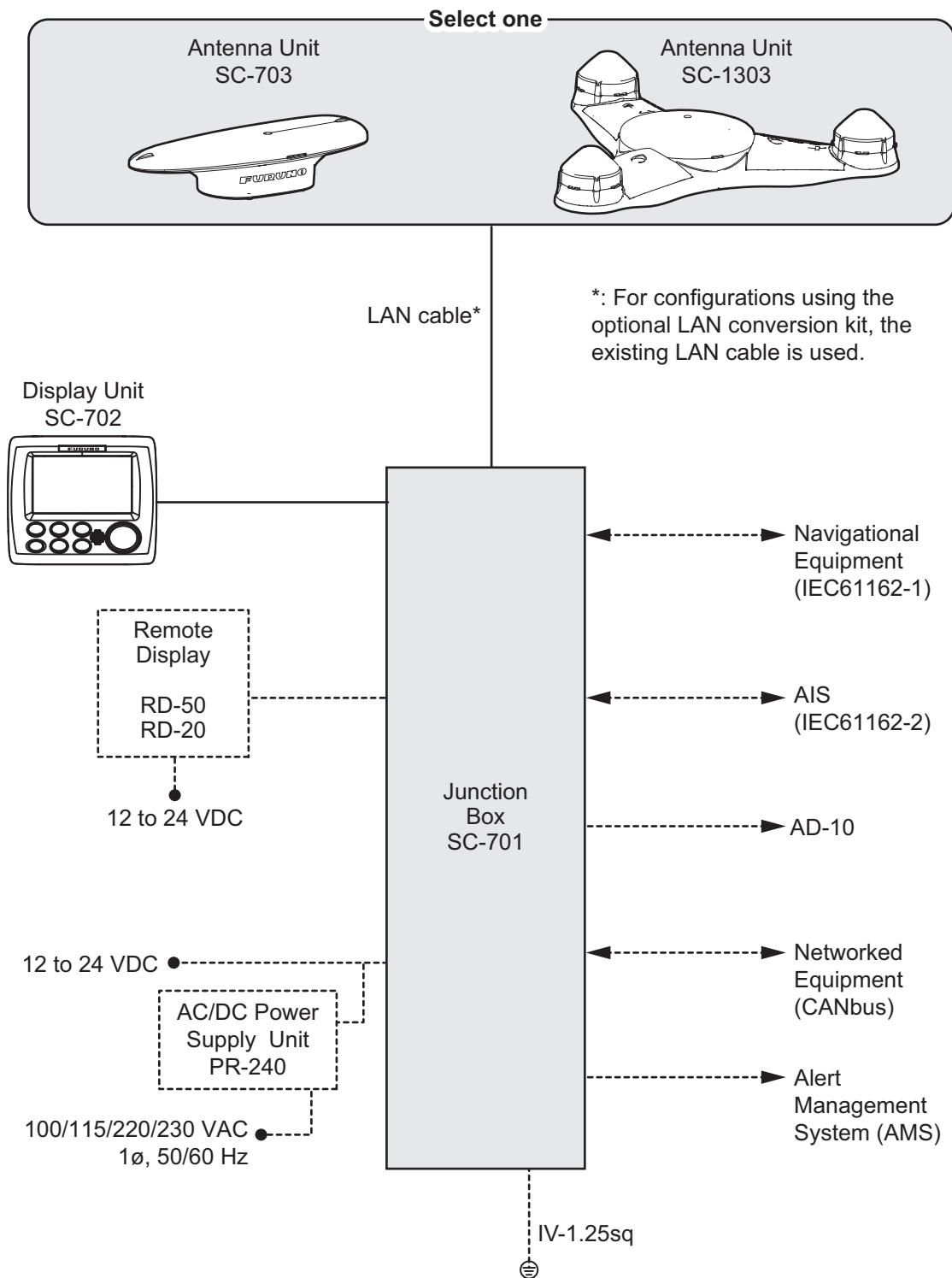

**Environmental categories:**

Antenna units:	Exposed to the weather.
Other units:	Protected from the weather.

—————: Standard supply  
 - - - - -: Optional/local supply

# EQUIPMENT LIST

## Standard supply

Name	Type	Code No.	Qty.	Remarks	
Antenna unit	SC-703	-	Select one	-	
	SC-703-L			Contains LAN-Coax conversion kit.	
	SC-1303				
	SC-1303-L			Contains LAN-Coax conversion kit.	
Display Unit	SC-702	-	1	-	
Junction Box	SC-701	-	Select one	-	
	SC-701-L	-		Contains LAN-Coax conversion kit.	
Installation materials	CP20-04300	000-033-318	Select one	LAN cable (30 m) for SC-701 to Antenna Unit connection.	
	CP20-04310	000-033-319		LAN cable (40 m) for SC-701 to Antenna Unit connection.	
	CP20-04320	000-033-320		LAN cable (50 m) for SC-701 to Antenna Unit connection.	
	CP20-04330	000-033-321		LAN cable (15 m) for SC-701 to Antenna Unit connection. No armor, with connector attached.	
	CP20-04340	000-033-322		LAN cable (30 m) for SC-701 to Antenna Unit connection. No armor, with connector attached.	
	CP20-04350	000-033-323		LAN cable (15 m) for SC-701 to Antenna Unit connection. No armor, with separate connector.	
	CP20-04360	000-033-324		LAN cable (30 m) for SC-701 to Antenna Unit connection. No armor, with separate connector.	
	CP20-04370	000-035-430		LAN cable (10 m) for SC-701 to Antenna Unit connection, with separate connector.	
	CP20-04380	000-035-431		LAN cable (15 m) for SC-701 to Antenna Unit connection, with separate connector.	
	CP20-04500	000-035-432		LAN cable (10 m) for SC-701 to Antenna Unit connection, with connector attached.	
	CP20-04510	000-035-433		LAN cable (15 m) for SC-701 to Antenna Unit connection, with connector attached.	
	CP20-04201	001-514-460		1	For SC-703.
	CP20-04202	001-514-570		1	For SC-1303.
	CP20-04001	001-514-470		1	For SC-701.
	CP20-04101	001-521-480		1	For SC-702.
	CP20-04100	000-035-376		Select one	For SC-702-E-1. 10 m cable.
CP20-04110	000-035-377	For SC-702-E-3. 30 m cable.			
Spare parts	SP20-01801	001-516-680	1	For SC-701. (Fuses × 2)	

Name	Type	Code No.	Qty.	Remarks
Accessories	FP19-01201	001-517-360	1	For SC-702. Front panel remover. (19-028-3124-1. Code: 100-340-471-10)

**Optional supply**

Name	Type	Code No.	Remarks
Interface Unit	IF-2503	000-010-101	-
	IF-NMEA SC	000-011-469	For analog output.
AC/DC Power Supply Unit	PR-240	000-013-632	100 VAC to 115 VAC, 200 VAC to 230 VAC
Remote Display Unit	RD-50	-	-
	RD-20	-	-
Cable Assembly (For NMEA2000)	M12-05BFFM-010	001-105-780-10	For NMEA2000 equipment connection.
	M12-05BFFM-020	001-105-790-10	
	M12-05BFFM-060	001-105-800-10	
LAN cable (For AMS or dual configurations)	FR-FTPC-CY *10M*	001-240-510	For AMS connection.
	FR-FTPC-CY *20M*	001-240-520	
	FR-FTPC-CY *30M*	001-240-530	
3 Pair Cable	Z-#26X2P+0.3SQX1PL30	000-192-277-10	For SC-702, 30 m
	Z-#26X2P+0.3SQX1PL10	000-192-276-10	For SC-702, 10 m
Connector (waterproof)	FRU-RJ-PLUG-ASSY	000-192-316-10	For connection between SC-701 and SC-703/SC-1303.
Bird Repellent Fixture	OP20-37	004-380-840	Single.
	OP20-36	004-380-830	Four pieces.
	OP20-49	001-482-870	Seven pieces.
Front Fixing Panel	OP24-35	001-247-240	For SC-702.
Water Proof Kit	OP05-139	001-426-500	For SC-702.
F_Mount Cushion Kit	OP05-141	001-436-880	For SC-702.
LAN_CNV kit	OP20-47	001-516-110	For SC-701.
	OP20-48	001-516-120	For SC-703/SC-1303.
Modular Connector	MPS588-C	001-459-840	For LAN cable.
Micro T-Connector	SS-050505-FMF-TS001	000-168-603-10	
Termination Resistor (Micro)	LTWMC-05BFFT-SL8001	000-168-605-10	
	LTWMC-05BMMT-SL8001	000-168-604-10	

This page is intentionally left blank.

# 1. INSTALLATION

---

This chapter covers the installation procedure and initial set up procedures and settings for the SC-70 and SC-130 systems.

**Note:** The settings and procedures outlined in this chapter are for technical personnel and should not be adjusted or changed by the user. If you require a change to any of these settings, contact your dealer.

## NOTICE

**Do not apply paint, anti-corrosive sealant or contact spray to coating or plastic parts of the equipment.**

Those items contain organic solvents that can damage coating and plastic parts, especially plastic connectors.

## 1.1 How to Install the Antenna Units

### General considerations

- Keep the length of the antenna cable in mind when selecting a mounting location.
- Select a location with minimal or no vibration.
- The sensor should be separated more than three meters from Inmarsat F/FB antennas. Select a location outside this transmission area.
- Do not loop the antenna cable or bundle the antenna cable with radio equipment cables. When these noise reductions are insufficient, adjust the squelch on the radio equipment.
- Select a location with obstructions to the radio waves.
- Select a location more than a meter from the floor/deck etc.
- Select a location with no local vibration or impact (including sympathetic vibrations due to engine or mast) for the GPS sensor in the antenna unit.

### Installing the antenna above superstructures

It is recommended that the antenna is installed above all other superstructures on the vessel. The antenna can obtain an unobstructed view of the available satellites, regardless of the vessel heading. Failure to install the antenna above all other superstructures can cause shadows and multipath reflection problems.

The following figure shows an example of the antenna installed above all other superstructures.

1. INSTALLATION

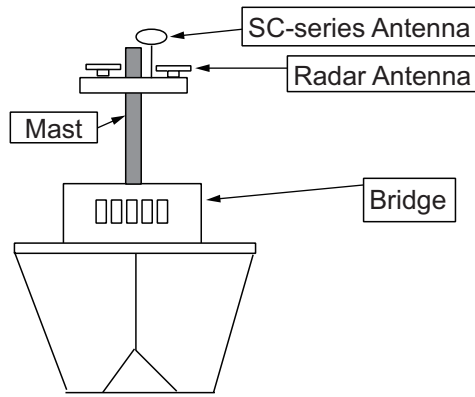

**Installing the antenna below superstructures**

Where the antenna is installed below superstructures on the vessel, shadows and multipath problems may occur on at least one heading, and possibly more. To avoid these problems where possible, follow the guidelines in this section.

**Note:** If the antenna is installed below any superstructure, the installation must be done over a two-day period, following the procedure in the service manual. At least 12 hours are required to capture tracking data to measure multipath indexes and locate areas of shading.

- The horizontal separation between the antenna and masts must be as shown in the table below and the figure on the following page:

Mast diameter	Minimum separation distance
10 cm	1.5 m
30 cm	3 m

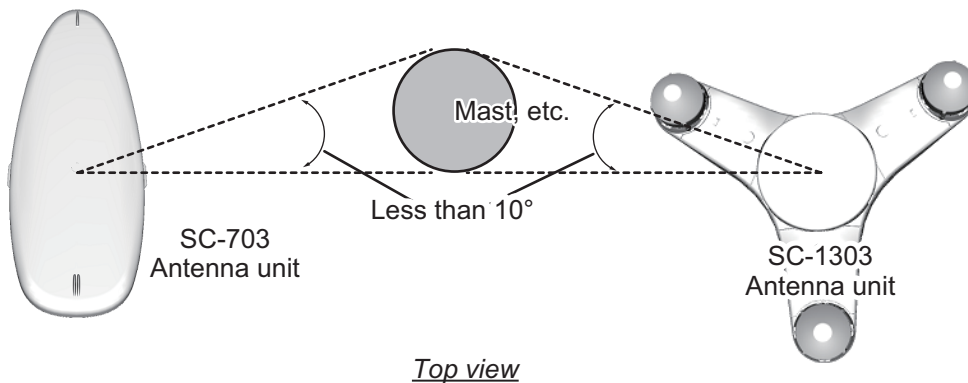
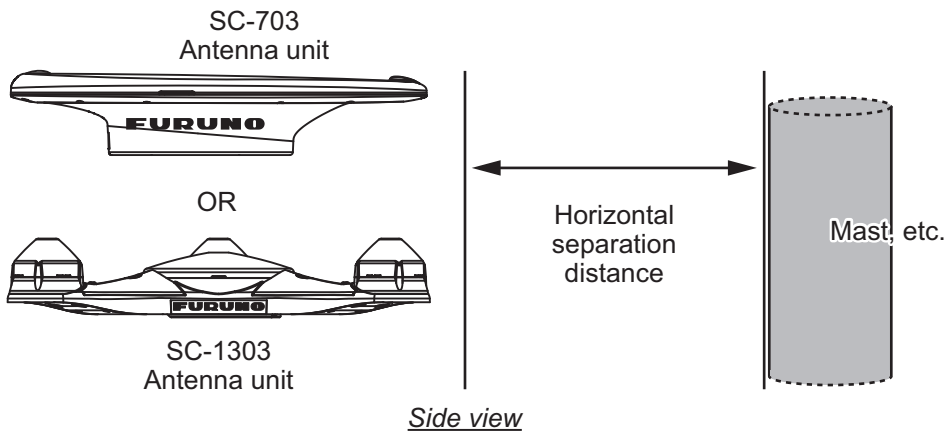



- The field of view above the antenna should be as shown in the figure below,  $\pm 80^\circ$  against the zenith. To avoid reflections from masts and other obstacles, locate the antenna well away from shadows of the radar mast, etc.

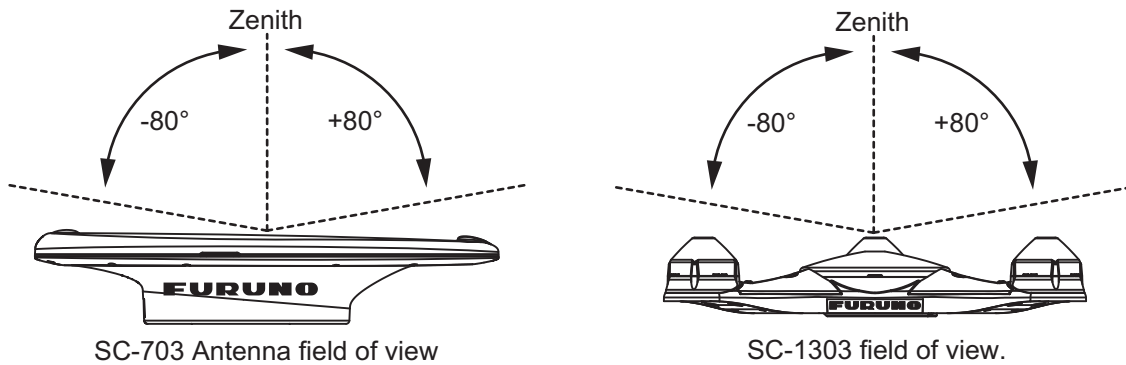

- Locate the antenna unit above the radar, out of the radar beam.

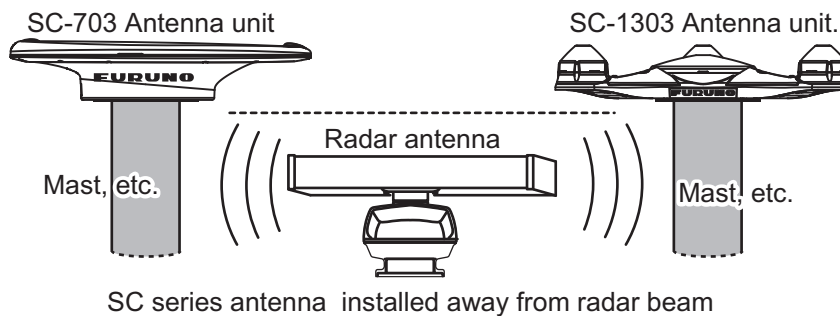

### 1.1.1 How to install the SC-703 Antenna Unit

**Note 1:** Where the installation location is inconvenient for cable connection, connect the cabling (see step 6) before securing the antenna unit to the mounting location.

**Note 2:** The bird-repellent fixtures can be attached to the antenna cover to prevent birds from landing on the cover. If it is more convenient to attach the bird repellent fixtures before securing the antenna unit to the mounting location, do step 7 of the procedure below before fixing the antenna unit.

- Prepare a mounting platform in accordance with the outline drawing at the back of this manual. If corrosive material is used, take necessary anti-corrosion measures.
 

**Note:** Holes drilled into the mounting platform must be parallel with the fore-aft line of the vessel.
- Orient the antenna unit to face the bow, referring to the figure below. The antenna should be installed within  $\pm 2.5^\circ$  of the bowline.
 

**Note:** The antenna cable must be routed via the indent at the rear of the base (see the following figure).

# 1. INSTALLATION

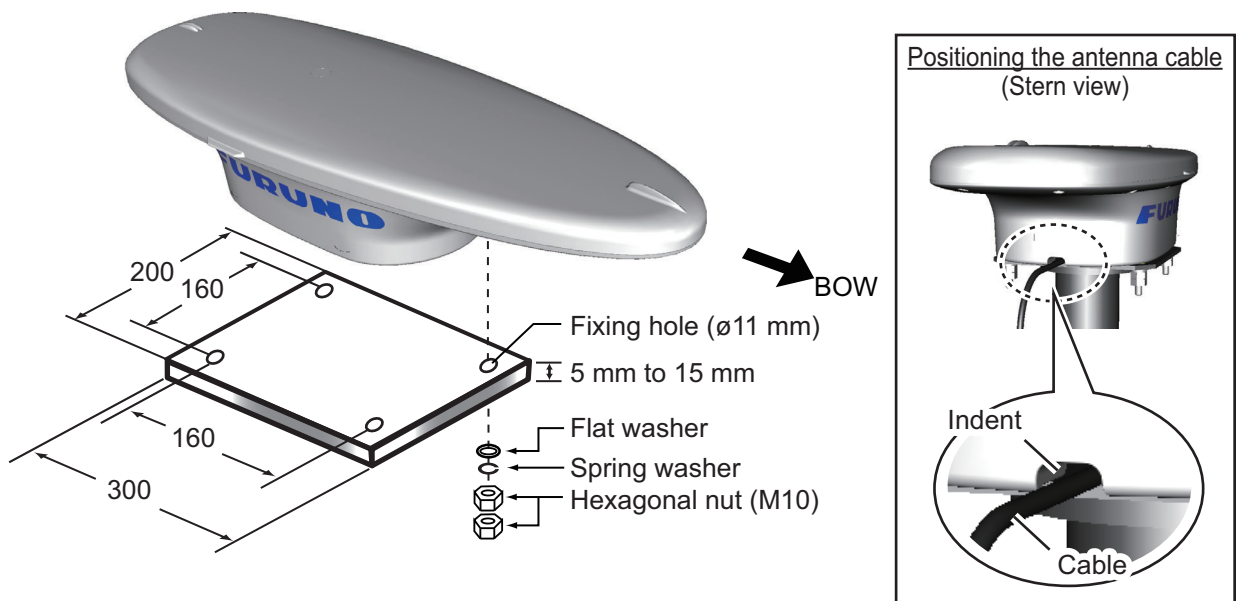

- Secure the unit to the platform with four sets of M10 hex. nuts, spring washers and flat washers (all included as installation materials) with  $20 \pm 2$  Nm torque.  
**Note 1:** Take care not to crush the cabling when mounting the antenna to the platform.  
**Note 2:** Take care not to cover the breathing hole on the antenna.
- Coat the exposed parts of the nuts, bolts and washers with the Adhesive TB5211 (included) to prevent corrosion.

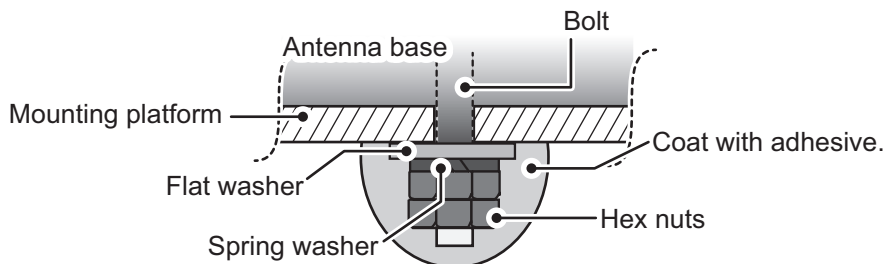

- Connect the SC-703 cable to the cable from the SC-701, then waterproof the connection (see section 1.5.2 for the waterproofing procedure).
- Remove the double-sided tape from the optional bird-repellent fixtures, then attach to the antenna cover. Coat around the bird-repellent fixtures with the Adhesive TB5211 (included).



- Secure the cables to the mast (or superstructure) with cable ties, at regular intervals.

## 1.1.2 How to install the SC-1303 Antenna Unit

**Note 1:** Where the installation location is inconvenient for cable connection, connect the cabling (see step 6) before securing the antenna unit to the mounting location.

**Note 2:** The bird-repellent fixtures can be attached to the antenna cover to prevent birds from landing on the cover. If it is more convenient to attach the bird repellent fixtures before securing the antenna unit to the mounting location, do step 8 before fixing the antenna unit.

1. Prepare a mounting platform in accordance with the outline drawing at the back of this manual. If corrosive material is used, take necessary anti-corrosion measures.

**Note:** Holes drilled into the mounting platform must be parallel with the fore-aft line of the vessel.

2. Orient the antenna unit to face the bow, referring to the figure below. The antenna should be installed within  $\pm 2.5^\circ$  of the bowline.

**Note:** The antenna cable must be routed via the indent at the rear of the base (see figure on the following page).

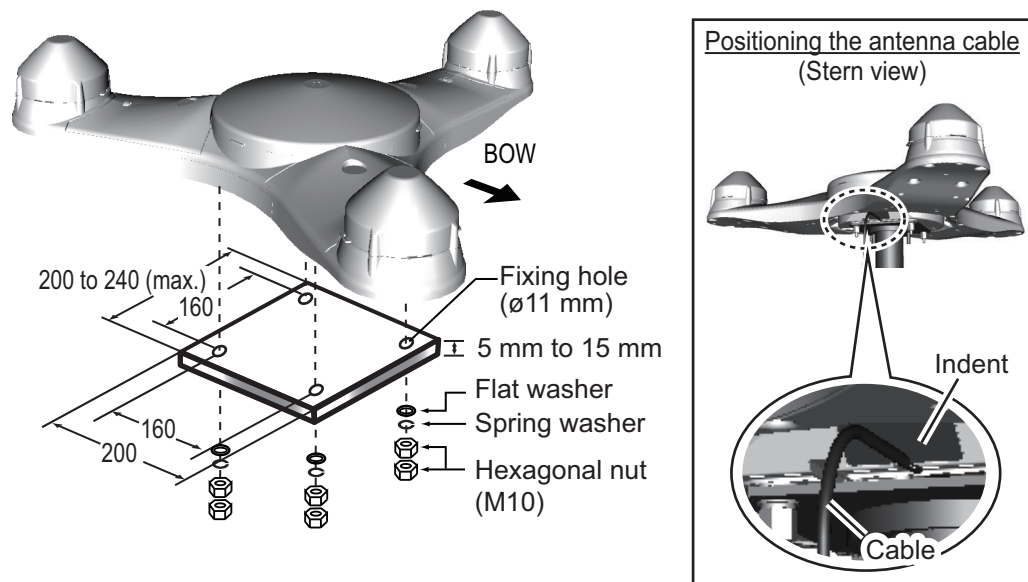

3. Coat the thread of the hex. bolts with silicone grease.
4. Fasten the unit to the platform with four sets of M10 hex. bolts, spring washers and flat washers with  $20 \pm 2$  Nm torque.  
**Note:** Take care not to crush the cabling when mounting the antenna to the platform.
5. Coat the exposed parts of the nuts, bolts and washers with the Adhesive TB5211 (included) to prevent corrosion.

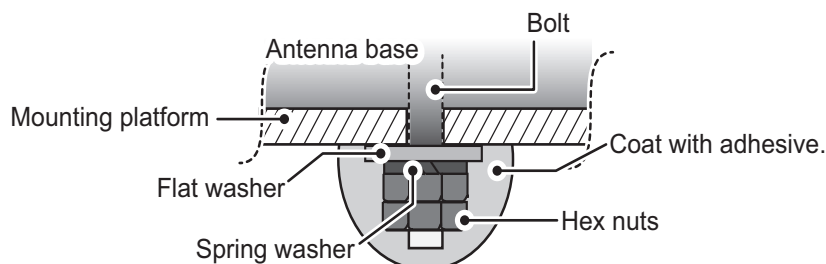

6. Connect the SC-1303 cable to the cable from the SC-701, then waterproof the connection (see section 1.5.2 for the waterproofing procedure).

## 1. INSTALLATION

- Remove the double-sided tape from the optional bird-repellent fixtures, then attach to the antenna cover. Coat around the bird-repellent fixtures with the Adhesive TB5211 (included).

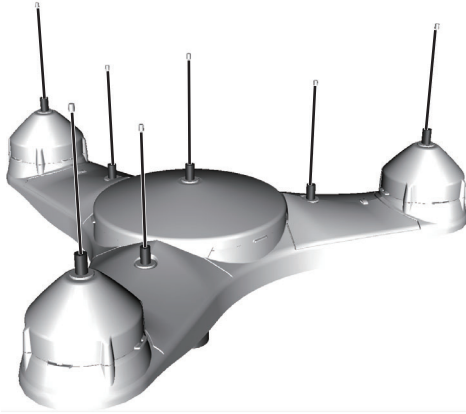

- Secure the cables to the mast (or superstructure) with cable ties, at regular intervals.

### 1.1.3 How to retrofit from SC-603/SC-1203

For retrofits from the SC-603 or SC-1203, the following attachments must be fabricated and attached to the mounting platform.

#### For SC-603 retrofits

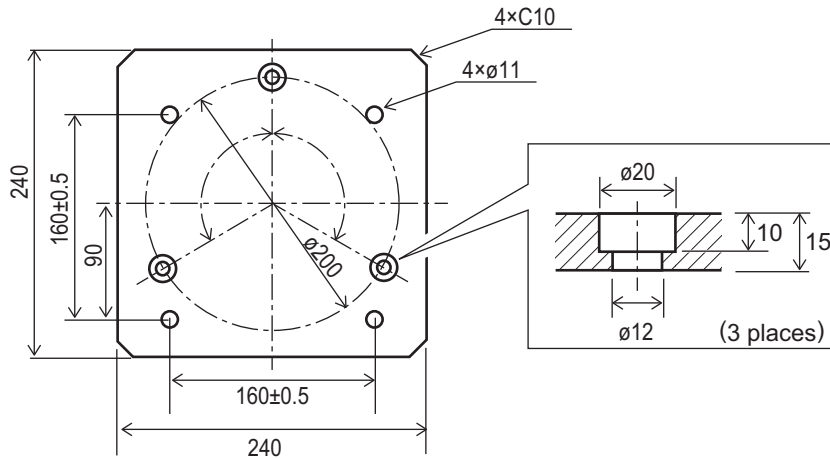

#### For SC-1203 retrofits

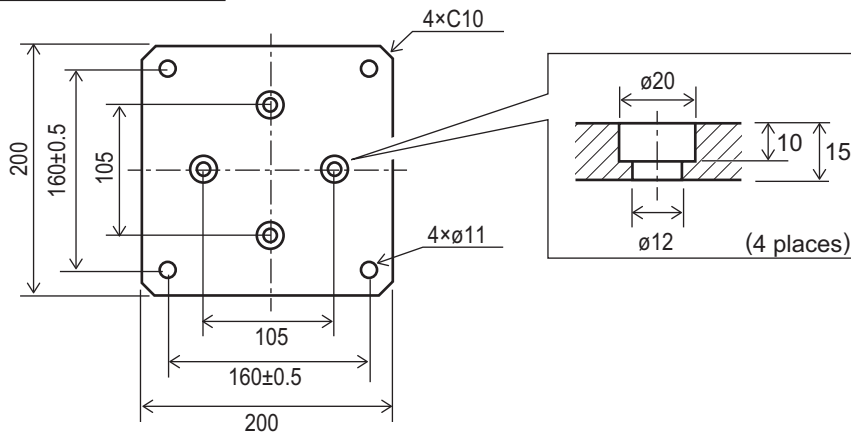

## 1.2 How to Install the Junction Box (SC-701)

The junction box can be mounted on the floor, bulkhead, on a desk/console or on the underside of a desk.

### Mounting considerations

Select a mounting location, keeping the following points in mind:

- Locate the SC-701 away from heat sources. Heat can build up inside the unit, causing damage to electrical parts.
- Locate the SC-701 away from areas prone to vibrations. The mounting location should have minimal vibrations.
- Locate the SC-701 away from areas prone to water splash and rain.
- Make sure to connect the unit's ground to the ship's ground.
- Leave sufficient space around the unit to allow access for maintenance. See the outline drawings at the back of this manual for the recommended maintenance space.
- A magnetic compass will be affected if the junction box is placed too close to the magnetic compass. Refer to the compass safe distances at the front of this manual when selecting a mounting location.
- The power switch has a small light which lights up when the unit is turned on.

**Note 1:** For wall/bulkhead mounted junction boxes, the cabling entrance indicated in the figure below must be oriented to face downwards, to avoid water entering the unit.

**Note 2:** For floor/desk mounted (top or bottom) junction boxes, select a location where water will not reach the cabling entrance indicated in the figure below.

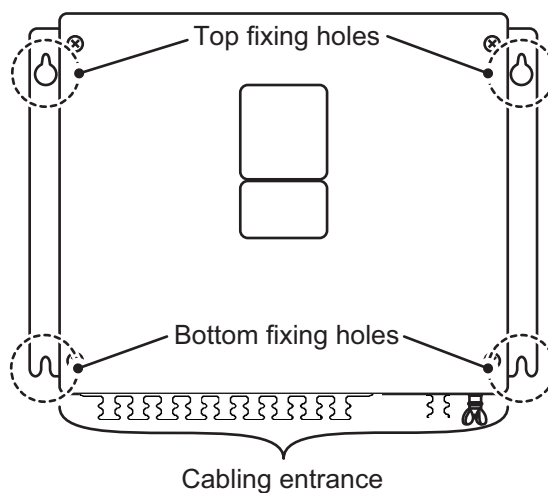

1. Referring to the outline drawing at the back of this manual, drill four pilot holes for the fixing screws.
2. Fasten two self-tapping screws ( $\phi 20$ , supplied) at the location for the top fixing holes. Leave approximately 5 mm of thread exposed.
3. Hang the SC-701 on the two screws using the two top fixing holes.
4. Fasten two self-tapping screws ( $\phi 20$ , supplied) to the bottom fixing holes.
5. Fasten all screws to secure the SC-701 in place.

## 1.3 How to Install the Display Unit (SC-702)

The display unit can be installed on a desktop, overhead (bulkhead) or flush mounted in a panel. Install the SC-702 on the chart table or near the helm, referring to the out-line drawing at the back of this manual.

### **Mounting considerations**

When selecting a mounting location for the display unit, keep the following in mind:

- Keep the unit out of direct sunlight.
- The temperature and humidity should be moderate and stable.  
(See the specifications at the back of this manual for operating temperatures.)
- Locate the unit away from heat sources, such as exhaust pipes and vents.
- The mounting location should be well ventilated.
- Keep the unit away from areas subject to rain or water splash.
- Install a ship-board earth to the grounding terminal at the rear of the unit.
- Mount the unit where shock and vibration are minimal.
- Keep the unit away from electromagnetic field generating equipment, such as motors and generators.
- Referring to the outline drawings at the back of this manual, leave sufficient space around the unit to allow access for maintenance.
- A magnetic compass will be affected if the unit is placed too close to it. Observe the compass safe distances listed on page ii to prevent magnetic disturbance.
- Leave enough slack in the unit's cabling to allow for maintenance and service.
- **For flush mount installations**, make sure the mounting location is flat.
- To avoid damage to the cabling when mounting the SC-702, make sure the cabling is not excessively bent.

### 1.3.1 How to install the SC-702 on a desktop or overhead

The display unit is shipped with the hanger, and must be removed from the hanger in order to be installed correctly.

1. Place the SC-702 on a firm, flat surface, then unfasten the two knobs on either side of the display unit to remove the unit.
2. Drill four holes for the self-tapping screws ( $\phi 5 \times 20$ ) at the installation location.
3. Secure the hanger to the desktop or overhead bulkhead with four self-tapping screws ( $\phi 5 \times 20$ , included). The hanger should be oriented with the insertion slots facing forwards. For mounting dimensions and required clearance, see the outline drawing at the back of this manual.

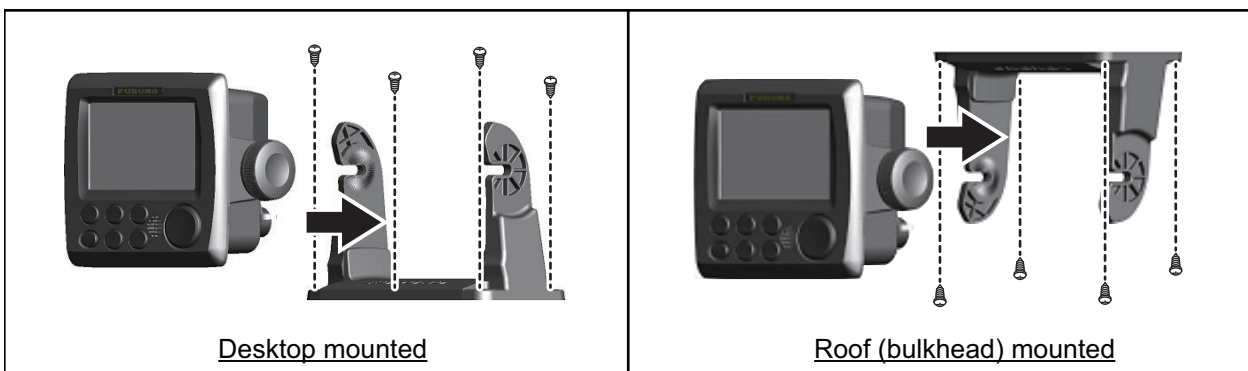

4. Referring to section 1.5.6, connect the cabling to the SC-702.
5. Fit the SC-702 to the hanger and tighten the bolts on either side evenly. Adjust the angle of the SC-702 so the screen can be viewed clearly.

### 1.3.2 How to flush mount the SC-702

There are two methods for flush mounting the SC-702. You can mount the unit directly onto the mounting area, or use the optional front fixing panel kit.

For both flush mount installation methods, the hanger and knobs are not required. remove the unit from the hanger and discard the hanger and knobs.

#### **Flush mounting the SC-702 (unit only)**

1. Cut a hole in the mounting location, using the template at the back of this manual.
2. Drill four holes for the self-tapping screws ( $\phi 5 \times 20$ ) at the installation location.
3. Place the SC-702 on a firm, flat surface, then unfasten the two knobs on either side of the display unit to remove the unit. The hanger can be disposed.
4. Gently lift the locking tabs at the rear of the front panel, then remove the front panel. Take care not to damage the locking tabs or the front panel.

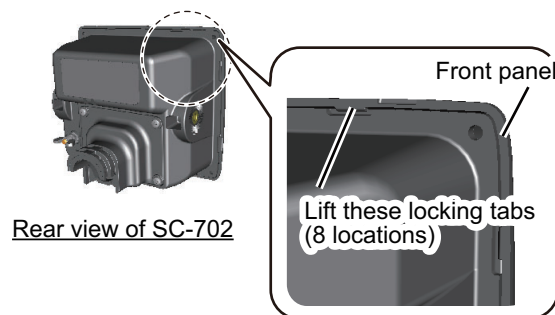

5. Fit the F Mount Cushion Kit (code: 20-032-106, included) to the rear of the SC-702 or to the mounting hole.
6. Run the cabling through the cutout, then, referring to section 1.5.6, connect the necessary cabling to the SC-702.
7. Referring to the figure below, fit the SC-702 to the cutout, then use the supplied self-tapping screws ( $\phi 3 \times 20$ ) to secure the SC-702 to the flush mount panel.

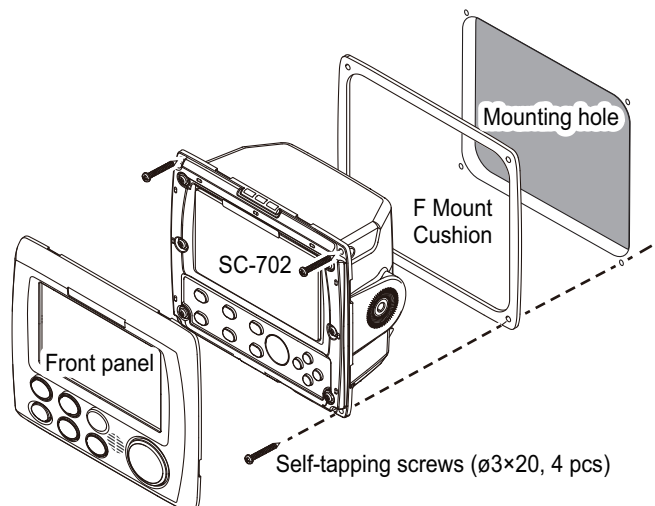

8. Re-fit the front panel that was removed at step 4.

## 1. INSTALLATION

**Note:** To remove the SC-702 from the mounting location, use the panel remover (FP19-01201, included).

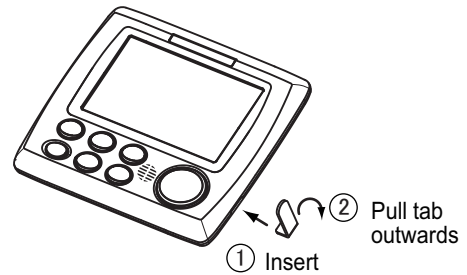

### **Flush mounting the SC-702 (with optional F Mount Panel)**

Use the optional kit (OP24-35), referring to the outline drawings at the back of this manual and the installation instructions (C42-01310) included with the optional kit.

## 1.4 How to Install the Remote Display Unit (option)

The RD-50/RD-20 can be connected as a ROTI (Rate Of Turn Indicator) display unit.

For installation instructions regarding the RD-50 or RD-20, see the appropriate operator's manual (RD-50: OME-44530-x, RD20: OME-44540-x; x denotes the manual version), included with your Remote Display.

**Note:** If your vessel is required to be ROTI type-test compliant, use the RD-50.



## 1.5 Wiring

This section covers general wiring. For further details see the interconnection diagram at the back of this manual.

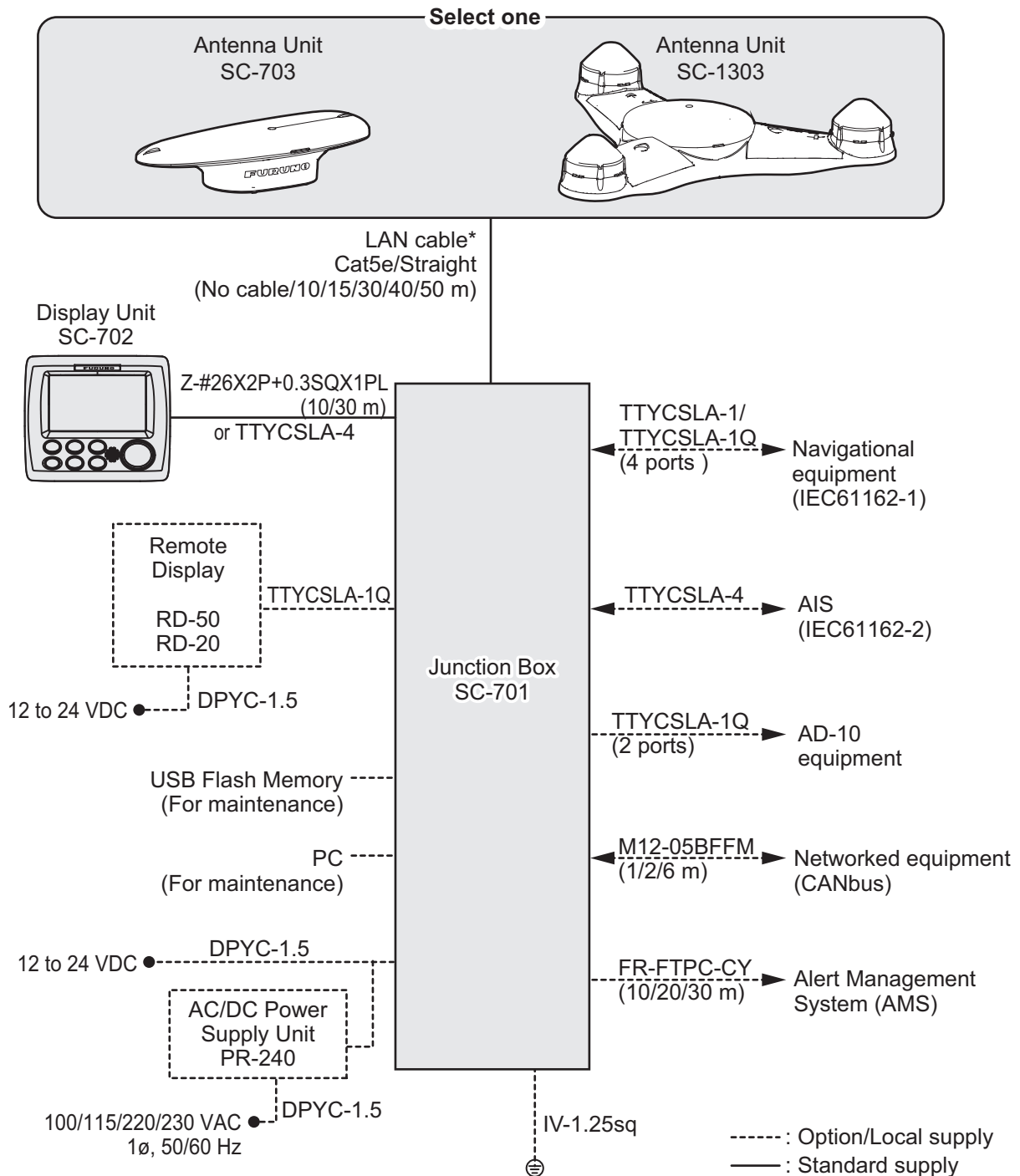

\*: Attach **the supplied modular connector to the supplied LAN cable**. Do not use a commercial STP cable (LAN cable) or connector due to their low durability. See "Mounting considerations" on page 1-8 for how to attach the modular plug. Also, when using the optional LAN CONV KIT, use the existing cables.

### 1.5.1 How to fabricate the cables

#### LAN cable

**Note 1:** When fabricating the LAN cable for connection to the antenna unit, remove the locking nut on the antenna base, then pass **the supplied LAN cable** through the cable entrance before fitting **the supplied modular plug** on the both ends.

- Modular plug for the junction box: MPS588-C
- Modular plug for the antenna unit: FRU-RJ-PLUG-ASSY

Secure to attach the shield (folded area) of the LAN cable to the chassis of the modular plug (see the following step 6). Then fit the locking nut on the LAN cable.

**Note 2:** This equipment only uses straight cables.

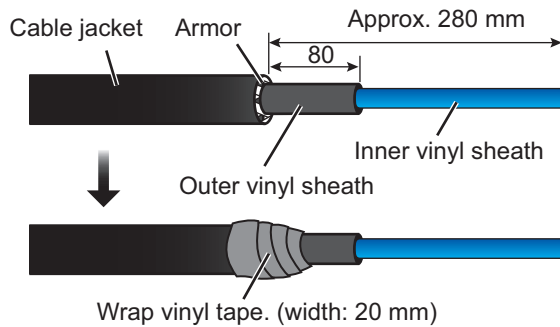

Expose the inner and outer sheaths as shown to the left.

Cover the cable jacket at the cut as shown to the left.



1 Expose inner vinyl sheath.

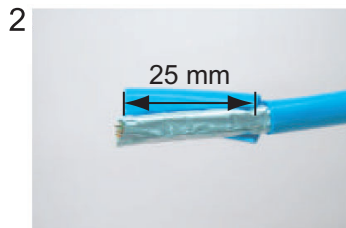

2 Remove the inner vinyl sheath by approx. 25 mm. Be careful not to damage inner shield and cores.

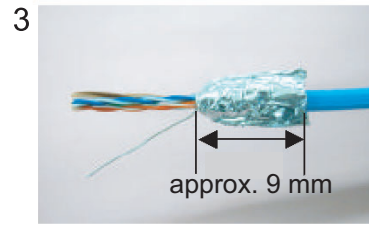

3 Fold back the shield, wrap it onto the inner vinyl sheath and cut it, leaving approx. 9 mm.

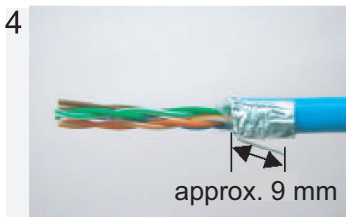

4 Fold back drain wire and cut it, leaving approx. 9 mm.

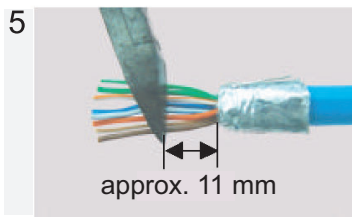

5 Straighten and flatten the cores in colored order and cut them, leaving approx. 11 mm.

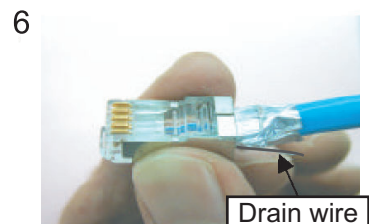

6 Insert the cable into the modular plug so that the folded part of the shield enters into the plug housing. The drain wire should be located on the tab side of the jack.



7 Using special crimping tool MPT5-8AS (PANDUIT CORP.), crimp the modular plug. Finally, check the plug visually.

#### Modular plug

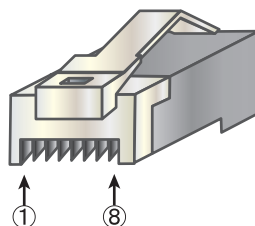

#### [Straight cable]

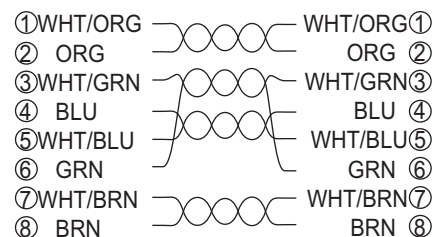

**Z-#26X2P+0.3SQX1PL10/30, TTYCSLA-1/1Q/4**

The supplied cable (Z-#26X2P+0.3SQX1PL10/30) does not have the armor.

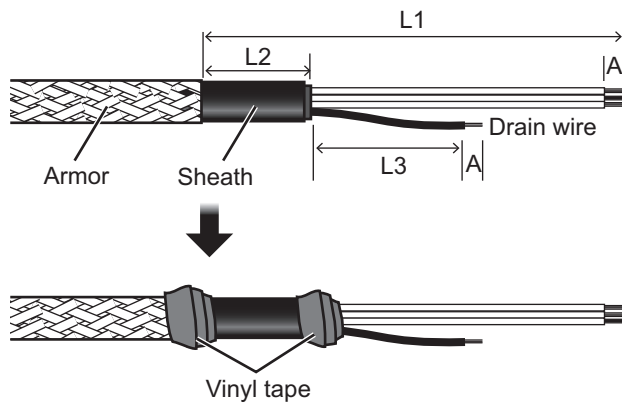

Measurements are displayed in mm

Unit	L1	L2	L3	A
Junction Box	*	80	80	6
Display Unit	130	80	50	6

\*: Length depends on installation configuration. When fabricating this cable, ensure enough slack is left to allow easy access for maintenance and service.

**Note:** L2 lengths displayed in the table above are the minimum recommended length. Adjust the length according to the installation configuration.

**Power cable DPYC-1.5**

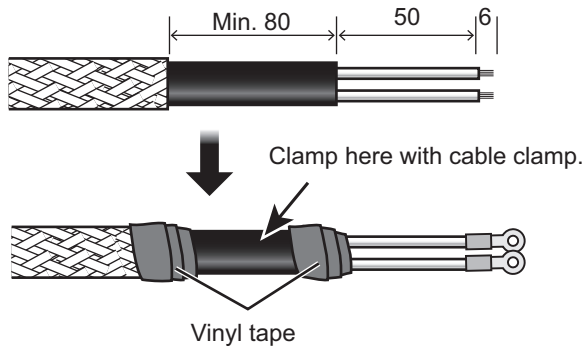

### 1.5.2 How to secure and waterproof the cable connections

All cable connections not inside the equipment, whether exposed to weather or otherwise, should be waterproofed and secured after making the connection.

To waterproof and secure each connection, refer to the procedure outlined below.

#### Securing and waterproofing connections

- 1) Wrap the connection with self-vulcanizing tape.

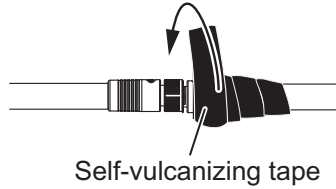

- 2) Wrap a second layer of self-vulcanizing tape in the opposite direction.

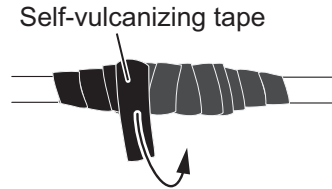

- 3) Wrap vinyl tape over the self-vulcanizing tape.

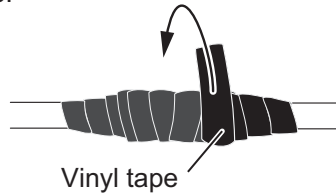

- 4) Wrap a second layer of vinyl tape in the opposite direction.

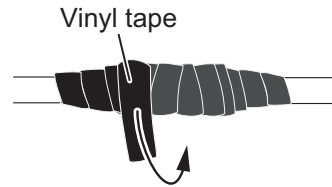

#### Securing and protecting unused cable connectors

- 1) Cover the loose end of the cable connector with self-vulcanizing tape.

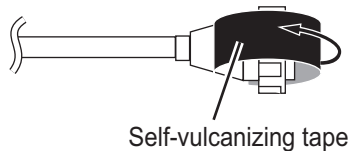

- 2) Wrap the connector with a layer of vulcanizing tape, covering approx. 50 mm of the connected cable. Confirm that the connector is covered.

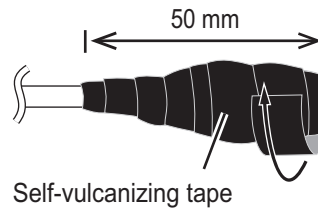

- 3) Wrap vinyl tape over the self-vulcanizing tape.



- 4) Wrap the connector with a layer of vinyl tape. Bind the tape end with a cable tie to prevent the tape from unraveling.

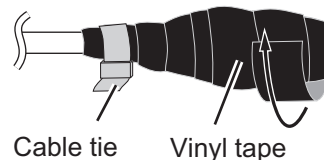

### 1.5.3 How to fabricate the WAGO connectors

Follow the procedure outlined below to fabricate the WAGO terminal connections.

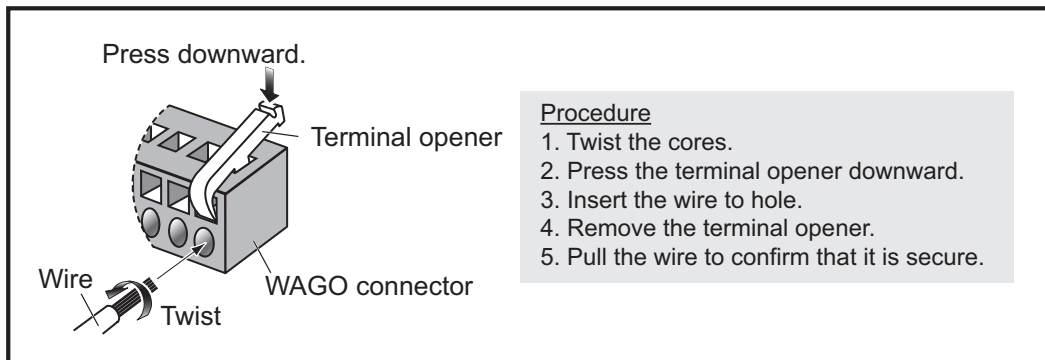

**Note:** Two terminal openers are included inside the SC-701. Check that the size of the opener is correct before use.

- Small opener (labeled as “DISP”): For use on connectors for cabling between the SC-702 and SC-701.
- Large opener: For use on the connectors inside the SC-701.

### 1.5.4 How to connect the Antenna Unit (SC-703/SC-1303)

Connect the LAN cable (included as installation materials; see table below) from the antenna LAN port to the J3 terminal inside the SC-701.

Installation materials type	LAN cable		Installation materials type	LAN cable	
	Length	Shielding		Length	Shielding
CP20-04300*	30 m	Yes	CP20-04370*	10 m	Yes
CP20-04310*	40 m	Yes	CP20-04380*	15 m	Yes
CP20-04320*	50 m	Yes	CP20-04500	10 m	Yes
CP20-04330	15 m	No	CP20-04510	15 m	Yes
CP20-04340	30 m	No	—		
CP20-04350*	15 m	No			
CP20-04360*	30 m	No			

#### How to fit the waterproof connector

Follow the procedure below to fit the waterproof connector (included in installation materials marked with “\*” in the above table).

*Waterproof connector components*

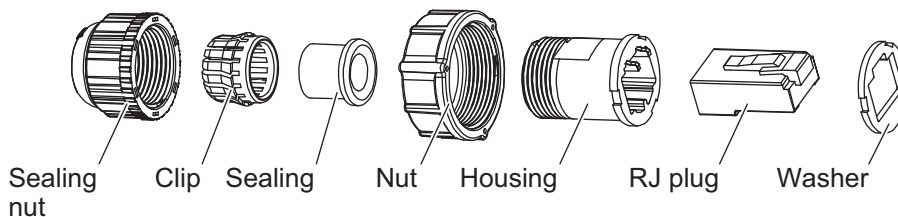

## 1. INSTALLATION

1. Referring to the figure below, fit the connector components to the LAN cable. Strip approximately 10 mm of the outer sheath to expose the cores, then fold the drain wire back, along the cable.

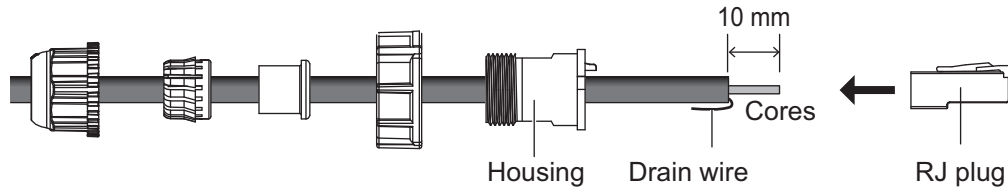

2. Insert the cable cores into the RJ plug, then secure the cores using a crimping tool (MPT5-8AS, or equivalent, local supply). Make sure the RJ plug is in contact with the drain wire.
3. Push the RJ plug into the housing. Make sure the RJ plug is aligned with the housing guides, then fit the nut, sealing, clip and sealing nut, in order.

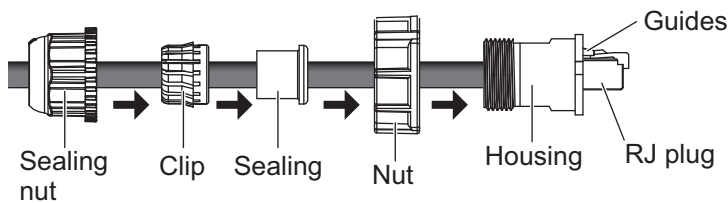

4. Fasten the sealing nut until the thread on the housing is not visible. Fastening torque: 0.72 to 0.98 N•m.

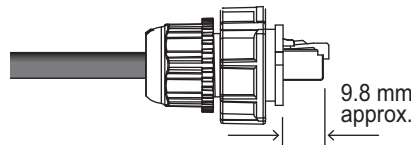

5. Fit the washer to the RJ connector, making sure that the indents on the washer match the indents on the connector.



6. Connect the assembled waterproof connector to the LAN cable on the antenna.
7. Use self-vulcanizing tape and vinyl tape to additionally waterproof the connection. For details on waterproofing cable connections, see section 1.5.2.

### **Retrofits - Coaxial cable connection**

You can use the existing coaxial cable for connection. In this case, the optional LAN\_CNV kits (OP20-47 and OP20-48) are required.

#### **Cable connection:**

For cable connection, use one of the three existing coaxial cables. Connect both ends of the cable, one end to the antenna unit, the other end to the junction box. Secure and protect the connection points of the coaxial cables, referring to paragraph 1.5.2.

For unused existing coaxial cables, secure and protect both ends of the coaxial cables, referring to paragraph 1.5.2.

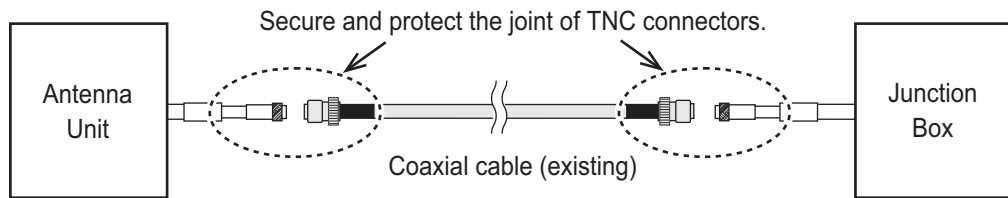

### 1.5.5 How to connect the Junction Box (SC-701)

The Junction Box (SC-701) has two rows of cable entrances for connection. The following figure and table show the internal connection points for the SC-701 and the recommended cable entrance for each connection (based on a configuration which uses all connections). The tables on the following pages show the pin connections for each WAGO connector.

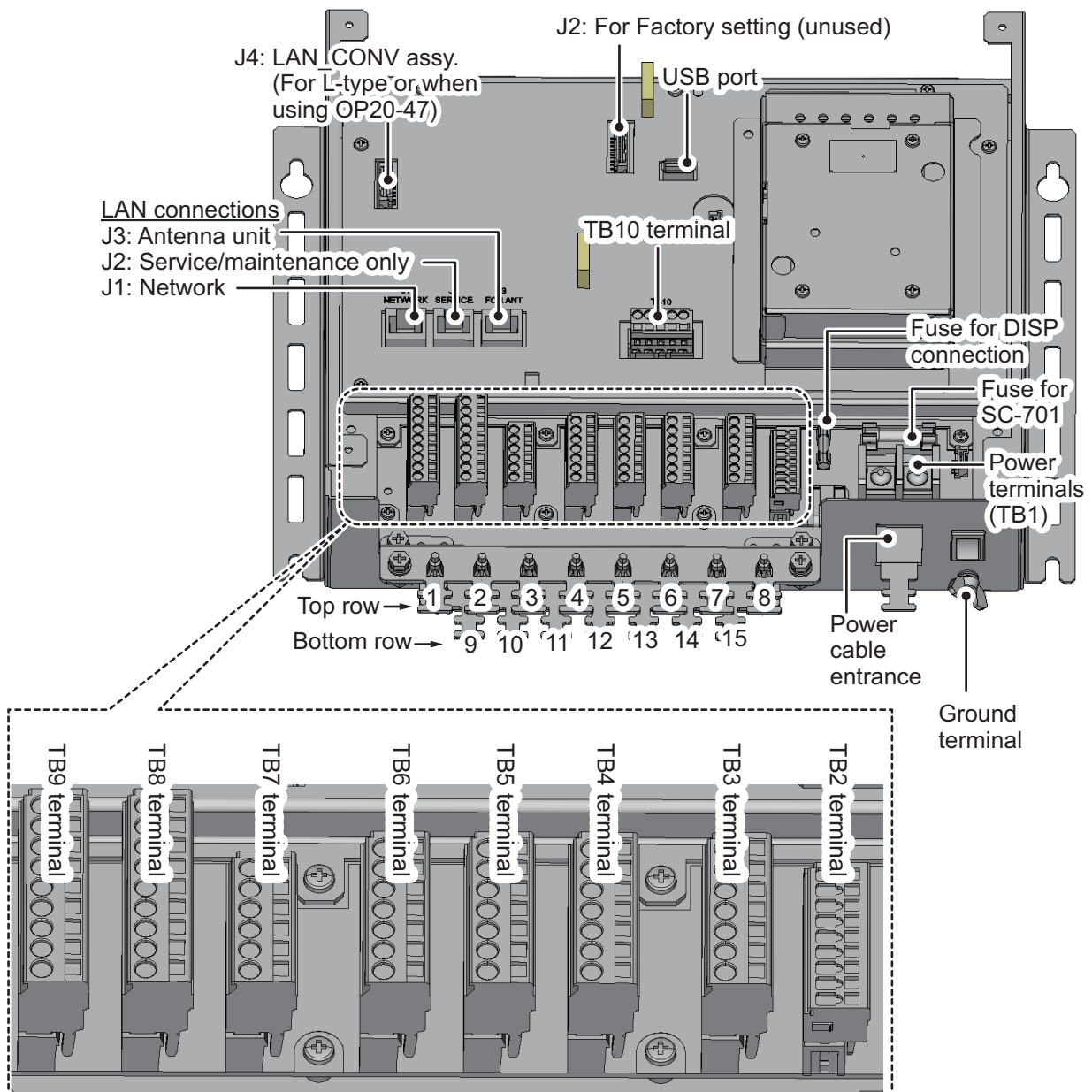

**Note 1:** LAN cable recommended entrances should be used to prevent undue stress to the LAN cables. The power and DISP cable must be passed through their recommended entrance to prevent damaged to the cabling.

## 1. INSTALLATION

**Note 2:** Cable entrances 1 through 8 are protected from foreign materials with a small plastic spacer. To use one these cable entrances, remove the spacer, then pass the cable through.

The table on the following page indicates the recommended cable entrance, connector number and the cable type required for connections to the SC-701.

External connection	Recommended entrance	Connector No.	Cable type
Power	Power cable entrance only	TB1	(JIS) DPYC-1.5
Shipboard network (AMS, etc.) (IEC61162-450)	1, 2 or 9	J1	(JIS) FR-FTPC-CY
Antenna unit (SC-703 or SC-1303)	9	J3	LAN
	10 or 11	LAN-Coaxial conversion kit	Existing coaxial.
AD-10 format data output	3 or 10	TB8 or TB9	(JIS) TTYCSLA-1Q
NMEA0183 (IEC61162-2)	3 or 10	TB7	(JIS) TTYCSLA-4
NMEA0183 (IEC61161-1)	4, 5, 6, 7 or 11, 12, 13, 14	TB3 to TB6	(JIS) TTYCSLA-1 or TTYCSLA-1Q
Display unit (SC-702)	15 only	TB2	(JIS) TTYCSLA-4
CANbus	4, 5, 6, 7 or 11, 12, 13, 14	TB10	M12-05BFFM** ("**" indicates length)
USB Flash Memory*	-	USB port	-

\*: To remove the USB Flash Memory, see "How to remove the USB Flash Memory" on page 3-4.

**Note:** For (JIS) cable equivalents, see the JIS cable guide at the back of this manual.

### **TB2 WAGO connector (9-pin, TTYCSLA-4)**

Pin no.	Connection (signal)	Description	Remarks
1	P12V	Power	-
2	GND	Grounding.	-
3			-
4			-
5	TD6_A	TX data	Fixed at 115200 bps.
6	TD6_B	TX data	
7	RD6_A	RX data	
8	RD6_B	RX data	
9	GND	Drain wire	Connect to drain wire.

### **TB3 to TB6WAGO connectors (7-pin, TTYCSLA-1/TTYCSLA-1Q)**

Pin no.	Connection (signal)	Description	Remarks	
1	TDx_1A	TX data	NMEA(Ver1.5/2.0/3.0/4.0), IEC61162-1	
2	TDx_1B	TX data	"x" denotes the connection to terminals as shown below.	
3	TDx_2A	TX data	<b>Signal</b>	<b>Terminal</b>
4	TDx_2B	TX data	TD/RD5	TB3



Pin no.	Connection (signal)	Description	Remarks	
5	RDx_H	RX data (Hot)	TD/RD4	TB4
6	RDx_C	RX data (Cold)	TD/RD3	TB5
7	GND	Drain wire	TD/RD2	TB6

**TB7 WAGO connector (6-pin, TTYCSLA-4)**

Pin no.	Connection (signal)	Description	Remarks
1	TD1_A	TX data	NMEA(Ver1.5/2.0/3.0/4.0) IEC61162-2
2	TD1_B	TX data	
3	RD1_A	RX data	
4	RD1_B	RX data	
5	ISO_GND	Isolating ground	
6	GND	Drain wire	

**TB8 WAGO connector (9-pin, TTYCSLA-1Q)**

Pin no.	Connection (signal)	Description	Remarks
1	DATA_3A	RS-485	Data output in AD-10 format.
2	DATA_3B		Shift output in AD-10 format.
3	SHIFT_3A		
4	SHIFT_3B		
5	DATA_4A		Data output in AD-10 format.
6	DATA_4B		Shift output in AD-10 format.
7	SHIFT_4A		
8	SHIFT_4B		
9	GND		

**TB9 WAGO connector (9-pin, TTYCSLA-1Q)**

Pin no.	Connection (signal)	Description	Remarks
1	DATA_1A	RS-485	Data output in AD-10 format.
2	DATA_1B		Shift output in AD-10 format.
3	SHIFT_1A		
4	SHIFT_1B		
5	DATA_2A		Data output in AD-10 format.
6	DATA_2B		Shift output in AD-10 format.
7	SHIFT_2A		
8	SHIFT_2B		
9	GND		

**TB10 WAGO connector (5-pin, M12-05BFFM-010/020/060)**

Pin no.	Connection (signal)	Description	Remarks
1	Shield	CAN_Shield	
2	NET_S	Power input	+9 V DC to +16 V DC
3	NET_C	CAN_GND	
4	NET_H	CANbus	Data I/O (Hot)
5	NET_L	CANbus	Data I/O (Cold)

### 1.5.6 How to connect the Display unit (SC-702)

The display unit is connected to the Junction Box using a 9-pin WAGO connector. Referring to section 1.5.3 and the table below, fabricate the WAGO connector. Note that the WAGO connector is included inside the SC-702 and must first be removed from the unit.

1. Unfasten the four screws on the rear cable clamp of the SC-702, then remove the cable clamp to reveal the WAGO connector.
2. Unplug the WAGO connector from the SC-702.
3. Pass the cable through the cable clamp.

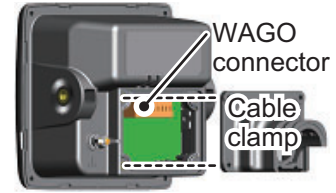

For the supplied cable (Z-#26X2P+0.3SQX1PL)

When the supplied cable is used, the supplied cable gasket (Type: 20-037-2104-0) must be attached. Open the cut line of the cable gasket then attach the cable gasket to the cable.

**Note:** To prevent water intrusion, the cut line of the cable gasket must face downward.

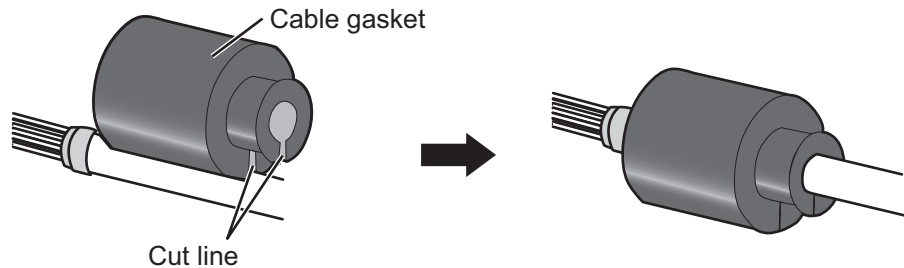

4. Referring to the following table and the interconnection diagram at the back of this manual, connect the cable to the WAGO connector.

**Display unit (SC-702) internal J301 WAGO connector (9-pin, TTYCSLA-4)**

Pin no.	Connection (signal)	Description	Remarks
1	P12V	Power	-
2	GND	Grounding. Connect to SC-701.	-
3			-
4			-
5	TD_A	TX data	Fixed at 115200 bps.
6	TD_B	TX data	
7	RD_A	RX data	
8	RD_B	RX data	
9	GND	Drain wire	Connect to drain wire.

5. Connect the cabling to the SC-702.
6. Slide the clamp along the cable towards the SC-702, then fasten the four screws which were removed at step 1.

7. Secure the cable to the cable clamp, referring to the figure below.

Top view of cable clamp

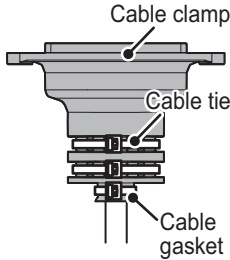
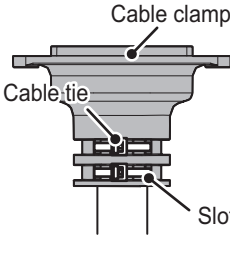
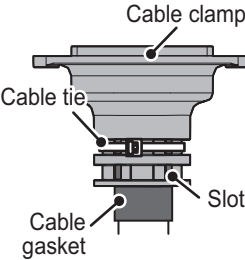
Supplied cable (Z-#26X2P+0.3SQX1PL)	Equivalent cable for JIS cable (TTYCSLA-4)	
	Without Water Proof Kit	With Water Proof Kit
With three cable ties	With two cable ties	With a single cable tie
 <p>Secure the cable gasket also with a cable tie.</p>	 <p>Wind cable ties through the slots.</p>	 <p>Wind a cable tie outside of the cable clamp.</p>

**Note:** In cases where the WAGO connector is connected to the cable before the cable is passed through the cable clamp, the cable clamp can be adjusted to allow connection. Adjusting the cable clamp as outlined in the figure below voids the IPx5 water-proof rating of the clamp and the unit.

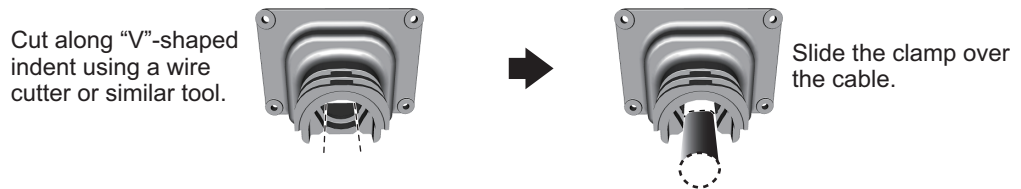

To keep the IPx5 rating, remove the WAGO connector, then repeat the procedure above.

## 1. INSTALLATION

### How to fit the optional waterproofing kit (OP05-139)

The optional waterproofing kit must be fitted at the same time as the cabling is connected to the SC-702.

**Note:** To satisfy the requirements for IPX5 waterproof rating, the cable used must have a diameter of 14.4 mm ( $\pm 0.4$  mm).

1. Unfasten the four screws on the rear cable clamp, then remove the cable clamp to reveal the WAGO connector.
2. Fit the cable gasket to the cable clamp, referring to the figure below.
  1. Fit the cable gasket to the cable clamp, passing the fixing lip partially through the cable clamp.
  2. To pass the fixing lip completely through the cable gasket, twist the cable gasket gently.

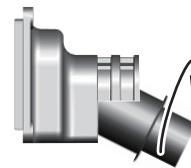
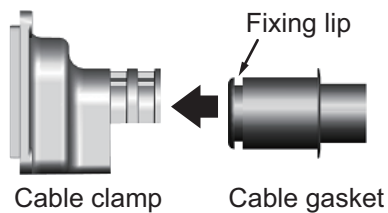

3. Check that the cable gasket is flush against the cable clamp, as shown below.

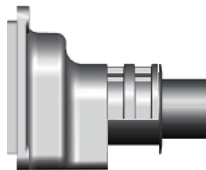

4. Check that the cable gasket's fixing lip is flush against the inside of the cable clamp.

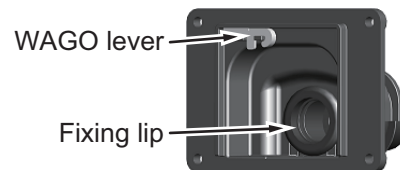

3. Pass the cabling through the cable gasket and cable clamp.
4. Fit the cover gasket (rubber seal) to the rear of the SC-702. Make sure the rubber seal is placed inside the groove indicated in the figure below.

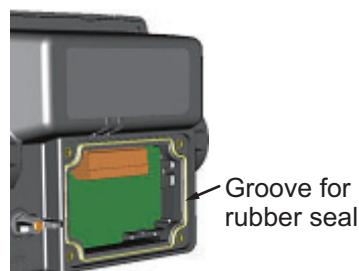

5. Connect the cabling to the SC-702, referring to section 1.5.6.
6. Slide the cable clamp along the cable until the clamp is flush against the rear of the SC-702.

**Note:** The cable clamp must be oriented with the dome facing upwards in order to retain its waterproofing rating.
7. Fasten the four screws removed at step 1.
8. Secure the cables to the cable clamp with cable ties.

### 1.5.7 How to connect the Remote Display Unit (option)

Connect the RD-50 to the SC-70/SC-130 referring to the connection diagram below.

#### RD-50 connection

**(For details, see the RD-50 Operator's Manual OME-44530)**

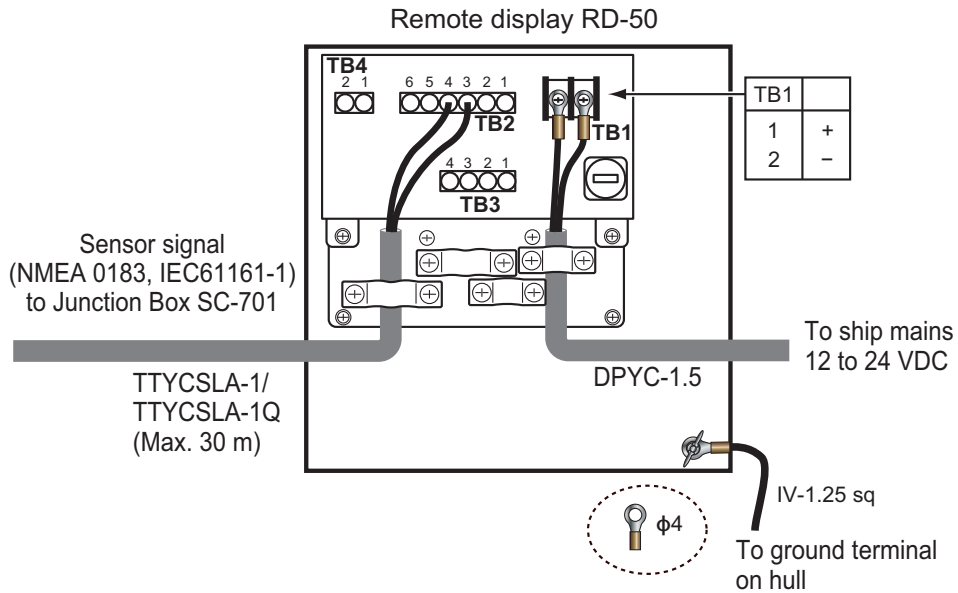

#### RD-20 Connection

**(For details, see the RD-20 Operator's Manual OME-44540)**

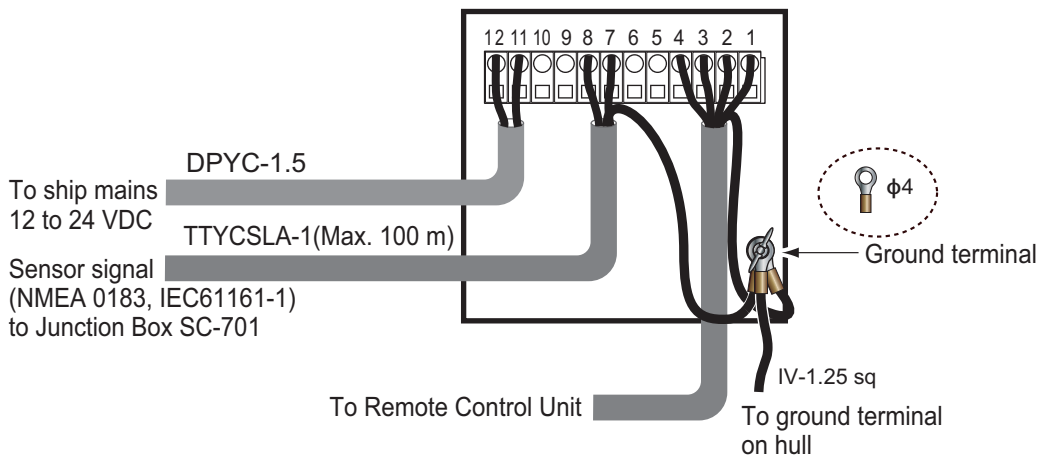

## 1.6 Initial Settings

The initial setup for your SC-70/SC-130 requires the system to be powered. Referring to the instructions at section 2.2, turn the power on.

For the sake of brevity, the following terminology is used.

Terminology	Meaning
"Select"	Example: "Select [SENSOR], then press the <b>ENT</b> key." Use the Cursorpad to select the menu item.
"Open the [MENU]."	Press the <b>MENU ESC</b> key; this opens the [MENU].
"Close the [MENU]."	<ul style="list-style-type: none"> <li>• Press the <b>MENU ESC</b> key; this closes the [MENU] and returns to the last used display screen or sub-screen.</li> <li>• Press the <b>DISP</b> key; this closes the [MENU] and returns to the main screen.</li> </ul>
IMO type	SC-70 or SC-130 systems which have been assigned as [MERCHANT] at installation and installed on vessels which meet the applicable IMO standards.
Non-IMO type	SC-70 or SC-130 systems which have been assigned as [FISHING] at installation and installed on vessels which do not meet the applicable IMO standards.

When the unit is powered for the first time, it is in a "cold start" state. There is no satellite data (almanac data) stored. In this state, the unit searches for, and stores, satellites to find its heading. This process takes approximately 90 seconds. If the heading is not found within 30 minutes, the antenna installation location may not be suitable. A lack of visible satellites (less than five) can also prevent the unit from finding a heading. Resolve the problem, then re-check the tracking status.

If the heading error is between 5° and 10°, adjust the antenna unit orientation while monitoring the heading indication on the SC-702.

Once a heading has been found, the following items may need setting or adjustment:

- Vessel dimensions.
- Antenna location.
- Offset heading, roll, pitch, heave, etc.
- Main device mode.
- Password (as necessary).
- Alert mode.
- Legacy sentence input.
- I/O menu settings as appropriate. (See section 1.8.)

**Note:** Some settings are set at installation and are non-selectable (gray in color) from the menu. These settings require password input. Password input is not covered in the setting procedures for these items. To adjust these settings, contact your dealer.

## 1.6.1 Main menu

### How to access the menu

The menu is locked with a password. Press the **MENU ESC** key to show the password input window (shown below-right).

If this is the first time the unit has been turned on, the password is not set at default. Press the **ENT** key to access the menu. It is recommended to set a new password in this case.

If the unit has a previously set password, input the password, then press the **ENT** key to access the menu.



**Note 1:** Password input is required to access the menu each time the unit is turned off, then on again.

**Note 2:** The menu closes automatically if no keys are pressed within one minute.

### How to change/set the password

1. Open the [MENU].
2. Select [SYSTEM], then press the **ENT** key.
3. Select [PASSWORD], then press the **ENT** key.
4. Select [CHANGE], then press the **ENT** key. An input window appears.

The currently selected input box is indicated with a small arrow to the left-side of the input box, as shown in the figure to the right.

To set the password for the first time, press the **ENT** key to select the [NEW PASSWORD] input box, then skip to step 6.

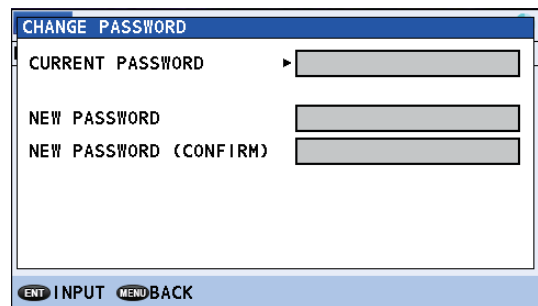

5. Enter the current user password. If the password is incorrect, the input window is reset to blank. If the password is correct, the arrow indication moves to the [NEW PASSWORD] input box.
6. Enter a new password, then press the **ENT** key. The arrow indication moves to the [NEW PASSWORD (CONFIRM)] input box.
7. Enter the new password again, then press the **ENT** key. If the passwords match, the [CHANGE PASSWORD] input window disappears. If the passwords do not match, the input boxes for [NEW PASSWORD] and [NEW PASSWORD (CONFIRM)] are reset and the arrow indication returns to the [NEW PASSWORD] box. Repeat the procedure from step 6.
8. Close the [MENU].

## 1. INSTALLATION

### How to disable access to the menu

Where necessary, you can disable menu access by doing the following:

1. Open the [MENU].
2. Select [SYSTEM], then press the **ENT** key.
3. Select [PASSWORD], then press the **ENT** key.
4. Select [LOGOUT], then press the **ENT** key. The menu closes.

### 1.6.2 How to set vessel dimensions, antenna location and CCRP

Access to the [OFFSET] menu requires the [SERVICE] menu to be unlocked. To unlock the service menu, see section 1.7.

1. Open the [MENU].
2. Select [SENSOR], then press the **ENT** key.
3. Select [OFFSET], press the **ENT** key.
4. Select [DIMENSIONS/CCRP], then press the **ENT** key. The settings window appears. The figure below is an example of the settings window.

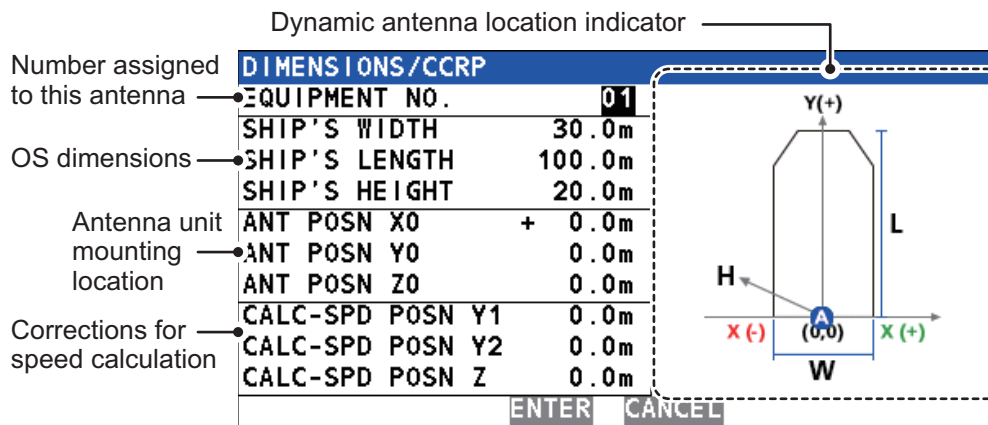

5. Select [EQUIPMENT NO.], then press the **ENT** key. The [INPUT EQUIPMENT NO.] pop up window appears.
6. Set the antenna number you wish to set the location for.
7. Select [ENTER], at the bottom of the pop up window, then press the **ENT** key. The antenna selected here is used to output the POS sentence to external equipment.
8. Select [SHIP'S WIDTH], then press the **ENT** key. A numerical pop up window appears. Referring to the figure above, set the dimensions of the vessel.
9. Set [SHIP'S LENGTH] and [SHIP'S HEIGHT] in a similar manner.
10. Referring to the table below, set the antenna mounting position (CCRP) and the speed calculation adjustments.

**Note:** These settings require CCRP and ship dimensions. Do step 5 and 6 before changing these settings.

Indication	Description	Setting range
[ANT POSN X0]	Port-starboard location of antenna unit. Enter a negative value for port-side, positive value for starboard-side. The center of the vessel is [0 m].	- ([SHIP'S WIDTH]/2) to + ([SHIP'S WIDTH]/2). For example, if the [SHIP'S WIDTH] is set to [100 m], the range is [-50 m] to [+50 m].



Indication	Description	Setting range
[ANT POSN Y0]	Bow-stern location of the antenna unit. Calculated from the center of the stern.	[0.0 m] to [SHIP'S LENGTH]. For example, if [SHIP'S LENGTH] is set to [45 m], the maximum range for this setting is also [45 m].
[ANT POSN Z0]	Height of antenna unit location, from the bottom of the ship.	[0.0 m] to [99.9 m]
[CALC-SPD POSN Y1]*	Ship's speed can be measured at two locations in addition to the antenna position. Enter the forward distance, calculated from the CCRP, to the location where you want to measure the ship's speed.	[0.0 m] to [SHIP'S LENGTH]. For example, if [SHIP'S LENGTH] is set to [45 m], the maximum range for this setting is also [45 m].
[CALC-SPD POSN Y2]*		[0.0 m] to [SHIP'S LENGTH]. For example, if [SHIP'S LENGTH] is set to [45 m], the maximum range for this setting is also [45 m].
[CALC-SPD POSN Z]*	Enter 0 to calculate the height from the bottom the ship. Enter the draught amount to calculate the height from the draught.	[0.0 m] to [ANT POS Z0].

\*: These settings are required in order to display correct data on the SPD display. See section 2.10.

11. To apply the settings, select [ENTER], then press the **ENT** key.  
To discard the changes and start again, select [CANCEL], then press the **ENT** key.
12. Close the [MENU].

### 1.6.3 How to apply offsets for heading/pitch/heave/roll/position

**Note:** Access to the [OFFSET] menu requires the [SERVICE] menu to be unlocked. To unlock the service menu, see section 1.7.

1. Open the [MENU].
2. Select [SENSOR], then press the **ENT** key.
3. Select [OFFSET], then press the **ENT** key.
4. Referring to the table below, select the appropriate item to offset, then press the **ENT** key.

Menu item	Description	Offset range
HDG OFFSET	Offset the heading.	-180° to +180°
PITCH OFFSET	Offset to compensate for pitch.	-10°000 to +10°000
ROLL OFFSET	Offset to compensate for roll.	
POSITION OFFSET	Offset the Own Ship position.	North/South: 00.0000' to 59.9999' East/West: 00.0000' to 59.9999'
DIMENSIONS/CCRP	Set the ship size, location of the antenna and CCRP.	See section 1.6.2.
SOG OFFSET	Offset the SOG.	-12.5% to +12.5%
ATM OFFSET	Offset atmospheric pressure.	-99.9 hPa to +99.9 hPa
TEMP OFFSET	Offset the temperature.	-99.9°C to +99.9°C

5. Use the arrows key to set the offset, then press the **ENT** key.
6. Close the [MENU].

## 1.7 How to Access and Use the [SERVICE] Menu

Menu items which require service level access are shown in gray. A password, obtained from FURUNO, is required to access the [SERVICE] menu. Several initial settings must be done from this menu to complete the setup of your SC-70 or SC-130. To adjust or change any of these settings, consult your local dealer.

## 1.8 I/O Menu Settings

To set which data to output to external equipment from the SC-70/ SC-130, see section 2.15.

## 1.9 Initial Settings for the Remote Display

After wiring is complete for all units in the configuration, setup the [ROTI Display] as follows. The RD-50 requires menu setup.

For detailed operational guidance for either Remote Display unit, see the appropriate Operator's Manual (RD-50: OME-44530-x, RD:20: OME-44540-x: "x" denotes version).

### How to setup the RD-50 for ROTI display.

1. Open the [SERVICE] menu for the RD-50.

<b>UNIT Name</b>	<b>: RD-50</b>
<b>Serial No</b>	<b>: 6408-XXXX</b>
<b>PWB No</b>	<b>: 26P0006-XX</b>
<b>Remote Dimmer</b>	<b>: Main</b>
<b>Depth Select</b>	<b>: Auto</b>
<b>Depth Position</b>	<b>: Single</b>
<b>L/L Digit</b>	<b>: 4digit</b>
<b>Without Checksum</b>	<b>: Disable</b>
<b>I/O Port</b>	
<b>Port1</b>	<b>: 4800</b>
<b>SIO Monitor</b>	
<b>Sensor Out</b>	<b>: ON</b>
<b>Device Mode</b>	<b>: Normal</b>
<b>LCD RESET</b>	
<b>SIM</b>	<b>: OFF</b>
<b>Service RESET</b>	
<b>[▲]/[▼] : Select</b>	
<b>[ENT] : Enter</b>	

XXXX: Serial number  
XX: Program version number

2. Select [Device Mode], then press the **ENT** key.  
**Note:** Do not change the settings for any other items in the [SYSTEM] menu for the RD-50.
3. Select [ROTI], then press the **ENT** key.
4. Press the **PWR** key to close the menu and turn off the power. When the power is next turned on, your RD-50 shows the [ROTI Display] from the SC-70/SC-130.

### How to setup the RD-20 for ROTI display

Press the **DISP** key on the RD-20 to show the ROTI display.

## 2. OPERATION

### 2.1 Controls Overview



No.	Key	Description
1	<b>BRILL</b>	<ul style="list-style-type: none"> <li>• Opens the [BRILL SETTING] window.</li> <li>• With the BRILL SETTING window open, adjusts the screen brilliance.</li> </ul>
2	<b>DISP</b>	<ul style="list-style-type: none"> <li>• <u>With the menu open:</u> Close the menu and return to the last used display mode's main screen.</li> <li>• <u>Without the menu open:</u> Change the display mode.</li> </ul>
3	<b>MENU ESC</b>	<ul style="list-style-type: none"> <li>• Open the main menu.</li> <li>• Close the menu and return to the last used screen.</li> <li>• Close settings pop up window and return to the last used menu.</li> </ul>
4	<b>ACK</b>	<ul style="list-style-type: none"> <li>• Acknowledge an individual alert and close the alert pop up message.</li> </ul>
5	<b>LIST</b>	<ul style="list-style-type: none"> <li>• Show the [LIST] display.</li> <li>• Cycle through the [LIST] display.</li> </ul>
6	<b>ENT</b>	<ul style="list-style-type: none"> <li>• Open a menu item.</li> <li>• Confirm selected setting in pop up window.</li> <li>• Switch between graphic and main display for the current device mode.</li> <li>• From the SPD main screen: Long press to reset track (for non-IMO types only).</li> </ul>
7	Cursorpad	<ul style="list-style-type: none"> <li>• Navigate menus. <ul style="list-style-type: none"> <li>◀ button: Go back one layer in the menu.</li> <li>▶ button: Open the selected menu item.</li> <li>▲ button: Move selection cursor to the item above the current selection.</li> <li>▼ button: Move selection cursor to the item below the current selection.</li> </ul> </li> <li>• Adjust settings. <ul style="list-style-type: none"> <li>◀ button: Move cursor to the left.</li> <li>▶ button: Move cursor to the right.</li> <li>▲ button: Increase the value of the selected item.</li> <li>▼ button: Decrease the value of the selected item.</li> </ul> </li> <li>• With [INTEGRITY] screen shown: scroll through the displayed data when more than one screen is available.</li> </ul>

## 2.2 How to Turn the Power On/Off

The power is turned on or off from the Junction Box (SC-701). Turn the SC-701 on/off to turn the SC-702 on/off.

The startup screen appears for five seconds, then the system starts a diagnostic test. The diagnostic test takes approximately 30 seconds to complete. After the diagnostic test is complete, the main screen appears. You can also bypass the diagnostic test and show the main screen at any time during the test, by pressing any key.

**Note 1:** If the startup process has one or more errors, the message "COMMUNICATION ERROR" appears at the bottom of the diagnostic test screen.

**Note 2:** The display may appear "sluggish" if the ambient temperature is low.

**Note 3:** Viewable angles may vary between daylight and nighttime.



Startup/initialize screen.  
Shown for approximately five seconds.

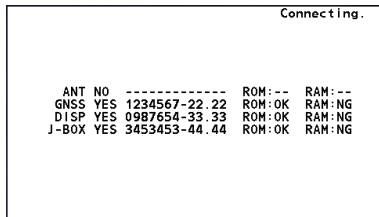

Self-test screen.  
Shown for approximately 30 seconds.

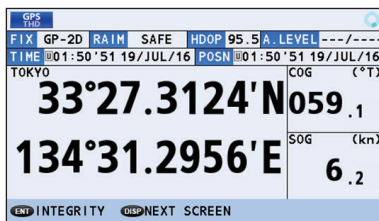

Main screen.  
For IMO type vessels: The preset [DEVICE MODE]\* screen appears.  
For non-IMO vessels: The last used screen appears.

\*: The [DEVICE MODE] is set at installation. To change this setting, consult your local dealer.

## 2.3 How to Adjust the Brilliance, Change the Background Color

The display unit (SC-702) has brilliance (brightness) controls for the screen and the key panel.

### 2.3.1 How to adjust the screen and key panel brilliance

To change the brilliance, do the following:

1. Press the **BRILL** key. The brilliance pop up window appears.

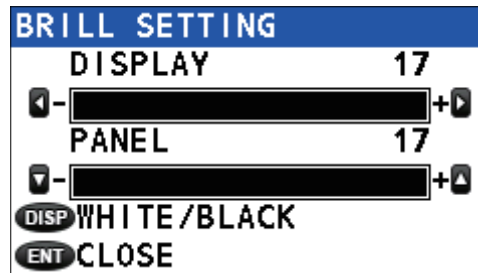

**Note:** The pop up window automatically disappears if there is no operation detected.

2. Press ◀ to reduce, or ▶ to increase, the display brilliance.
3. Press ▼ to reduce, or ▲ to increase, the key panel brilliance.
4. Press the **ENT** key to close the pop up window.

The factory default settings and setting range for brilliance are listed in the table below.

Display	Panel
Setting range: [1] to [17]	Setting Range: [0] to [17]
White background default: [14]	White background default: [10]
Black background default: [6]	Black background default: [10]

**Note:** The brilliance default setting for RD-50/RD-20 is [9], and the setting range is [0] to [9]. See the operator's manual (RD-50: OME-44530-x, RD:20: OME-44540-x; "x" denotes version) for details.

### 2.3.2 How to change the background and text color

1. Press the **BRILL** key to show the brilliance pop up window.
2. Press the **DISP** key to alternate background/text color.

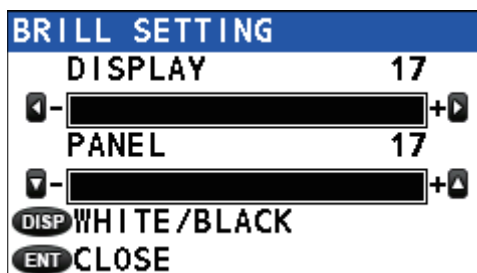

White background

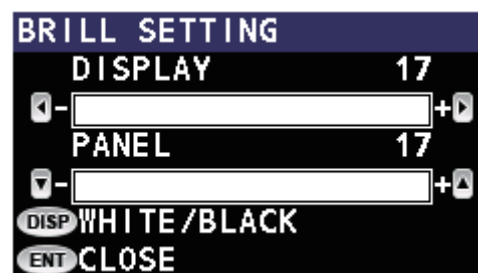

Black background

3. Press the **ENT** key to close the pop up window.

The background color can also be changed from the menu, see section 2.13.1.

## 2.4 Menu Overview

The main menu can be password protected. For information on how to access and operate the main menu, see section 1.6.1.

For the sake of brevity, the following terminology is used in this manual:

Terminology	Meaning
"Select"	Example: "Select [SENSOR], then press the <b>ENT</b> key." Use the Cursorpad to select the menu item.
"Open the [MENU]."	Press the <b>MENU ESC</b> key; this opens the [MENU].
"Close the [MENU]."	<ul style="list-style-type: none"> <li>Press the <b>MENU ESC</b> key; this closes the [MENU] and returns to the last used display screen or sub-screen.</li> <li>Press the <b>DISP</b> key; this closes the [MENU] and returns to the main screen.</li> </ul>
IMO type	SC-70 or SC-130 systems which have been assigned as [MERCHANT] at installation and installed on vessels which meet the applicable IMO standards.
Non-IMO type	SC-70 or SC-130 systems which have been assigned as [FISHING] at installation and installed on vessels which do not meet the applicable IMO standards.

**Note:** The default operation mode for the SC-70/SC-130 is [MERCHANT] (IMO compliant). [FISHING] is not compliant with the IMO regulations and must not be used for vessels which are required to be IMO compliant. To change the operation mode, consult your local dealer.

1. Press the **MENU ESC** key to open the menu.

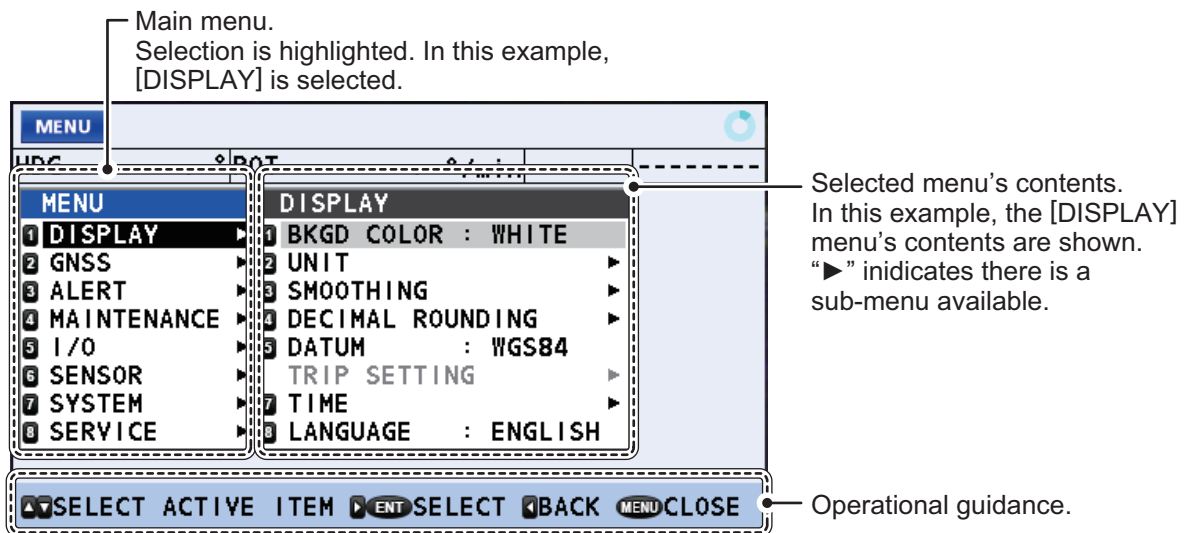

2. Press ▲ or ▼ to select a menu item, then press the **ENT** key.  
"▶" next to a menu item indicates that there is a sub-menu available.
3. Press the **MENU ESC** key to close the menu.

## 2.5 LIST Screens Overview

LIST display mode shows the [ACTIVE ALERT] list, [ALERT LOG] and [DEVICE LIST] in cyclic order with the display mode currently in use.

Press the **LIST** key to cycle through the lists in the order shown below. Press and hold the **LIST** key to cycle through the lists in reverse order.



## 2.6 Display Modes Overview

The available display modes are GPS, THD, ROTI and SPD.

**Note:** The SPD display mode is available only for non-IMO compliant vessels. If the device mode is changed to [MERCHANT] and the SPD display mode is in use, it is automatically changed to the THD display mode. Consult your local dealer for details.

### How to change the display mode

Press the **DISP** key to cycle through the display modes. The order in which the display modes are shown is: GPS → THD → ROTI → SPD → GPS...



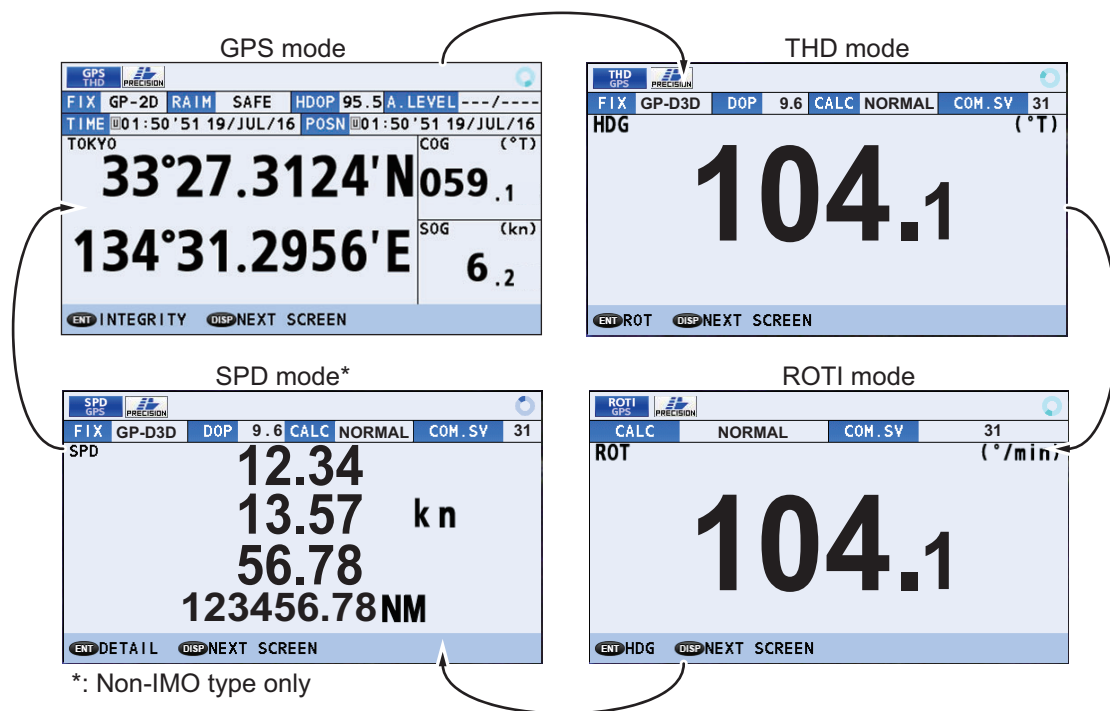

**Note:** Some display modes may not be available, depending on vessel configuration. The figures below shows all four available display modes.



### 2.6.1 Icons and indications

The top section of all device modes displays various icons and the operational status icon is always displayed. The example figure below shows all icons, along with a brief description.



No.	Description
1	<p>Indicates the displayed screen.</p> <p>Display mode icon: (Two-tier)  — Current display mode                      — Preset [DEVICE MODE] (Startup screen)</p> <p>Display mode icon: (Single-tier)  — Indication appears on one line when the currently selected screen matches the preset [DEVICE MODE].</p> <p>LIST screen: </p> <p>MENU screen: </p>
2	Precision indicator - displayed when five or more satellites are available for position fixing.
3	GNSS core number - shown for non IMO-types only. Shown only when GNSS core 1 is faulty; the substituted core number is shown here.
4	Simulation mode indicator. Shown only when the system is in simulation mode.
5	Excessive vibration icon - displayed when the antenna location is subjected to excessive vibration.
6	Operational status indicator - rotates in a clockwise direction when the system is operating normally. If this indicator does not move for more than 30 seconds, restart the equipment. For Non IMO-types, this icon is displayed in a light-blue color. For IMO-types, this icon is displayed in a dark blue color.

#### Alerts and operational guidance

The bottom section of the screen for all device display modes shows operational guidance and alerts.

Alerts take priority over guidance and must be acknowledged before normal operational guidance can be displayed again.

Operational guidance



Alert message (flashing)





## 2.7 GPS Display Mode

The GPS display mode has three display screens. Press the **ENT** key to cycle through the screens in the following order: Main screen → INTERGITY → BEACON/TYPE 16 MESSAGE → main screen...

### 2.7.1 GPS coordinates screen (main screen)

The GPS main screen shows own position, COG, SOG and other important GPS information.

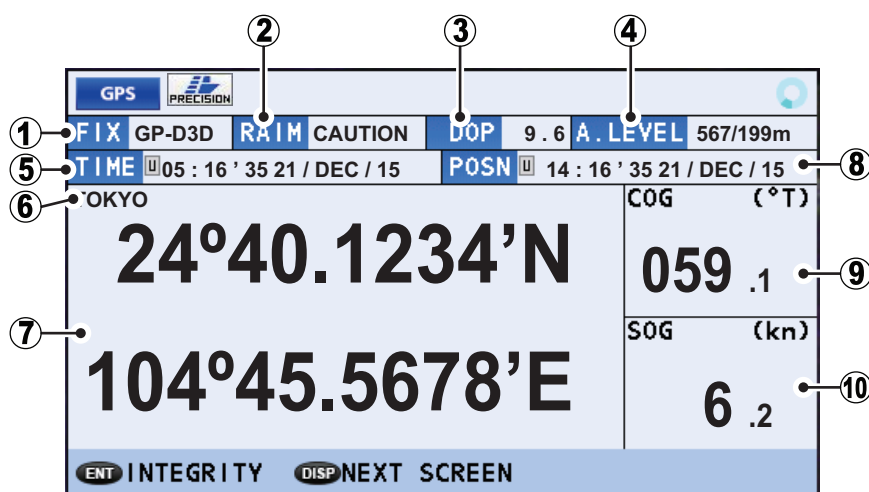

No.	Indication	Description
1	[FIX]	Current position fixing method (GP-3D, GP-D3D, etc.)
2	[RAIM]	Current RAIM status. <ul style="list-style-type: none"> <li>• SAFE: GPS signal is normal, positioning accuracy satisfies the setting value.</li> <li>• CAUTION: RAIM accuracy cannot be calculated. (Signals from more than five GPS satellites are necessary.) The positioning accuracy does not satisfy the setting value.</li> <li>• UNSAFE: GPS signal is abnormal, therefore the positioning accuracy is not reliable.</li> <li>• OFF: RAIM is disabled.</li> </ul>
3	[PDOP], [HDOP]	Current DOP (Dilution Of Precision). Displayed as PDOP for positional dilution, HDOP for horizontal dilution.
4	[A. LEVEL]	Accuracy offset for RAIM.
5	[TIME]	Time and date. Displayed with the prefix "L" for local time, "U" for UTC.
6	Datum	Current Datum in use.
7	Location	Own ship latitude and longitude (coordinates).
8	[POSN]	Time and date of last position calculation. Displayed in a orange color when the unit is restarted. When connection is established and positioning can be calculated, the indication changes to the opposite color of the setting selected from the [DISPLAY] → [BKGD COLOR] menu.
9	[COG]	Course Over Ground.
10	[SOG]	Speed Over Ground.

### 2.7.2 GPS integrity screen

The GPS integrity display shows satellite status and various integrity-related data, as shown in the figure and table below.

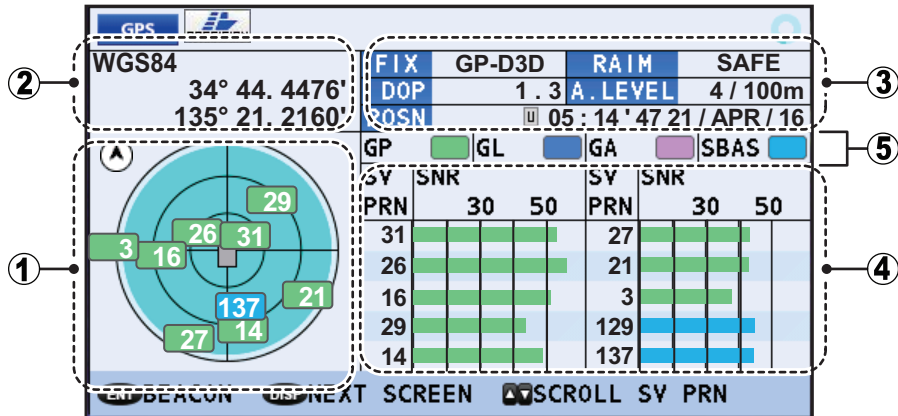

No.	Name	Description
1	Satellite positions	Shows the available satellites and their elevation. <ul style="list-style-type: none"> <li>Light blue shaded circle: Indicates area where multipath can be used.</li> <li>White numerals: Indicates satellites used for position fix.</li> <li>Own ship is shown at the center of the circle.</li> </ul> Press ► to alternate between North-Up and Head-Up orientations.
2	Own ship position/positioning reference	Shows OS coordinates and positioning reference.
3	Text data box	See section 2.7.1.
4	RX level	Shows the strength of the signal received from the satellite code. <ul style="list-style-type: none"> <li>[SV PRN]: Satellite number.</li> <li>[SNR]: Signal to Noise Ratio.</li> </ul> When more than 10 satellites are in use, press ▲ or ▼ to scroll through the list.
5	Satellite color codes	Shows the color code for the satellites currently in use. The displayed indications are abbreviated as follows: <ul style="list-style-type: none"> <li>[GP]: GPS.</li> <li>[GL]: GLONASS.</li> <li>[GA]: Galileo</li> <li>[SBAS]: SBAS</li> </ul>

### 2.7.3 BEACON INFO/TYPE 16 MESSAGE screen

The beacon information display screen has two information tabs, the [BEACON INFO] tab and the [TYPE16 MESSAGE] tab.

The GPS [BEACON INFO] tab displays important information about the selected GPS beacon.

The [TYPE16 MESSAGE] tab displays all received TYPE16 messages received from beacons.

To switch tabs, press either the ◀ or the ▶ arrow key.

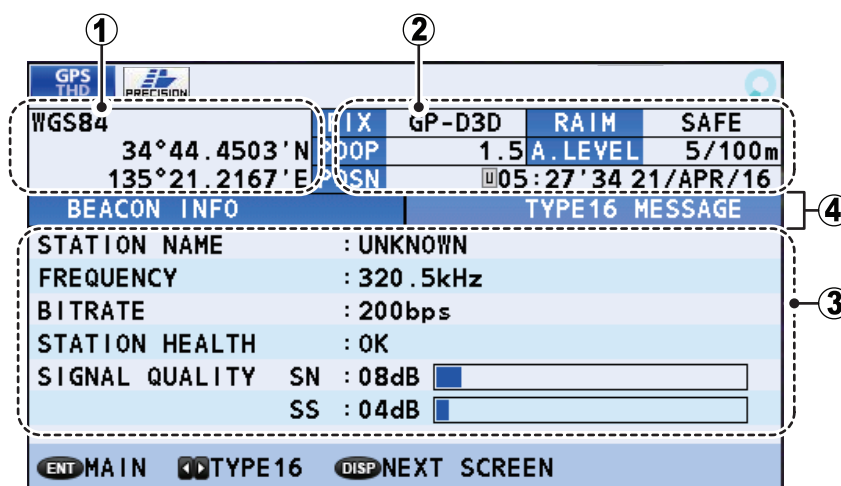

No.	Name	Description
1	Own ship position/positioning reference	Shows OS coordinates and positioning reference
2	Text data box	See section 2.7.1.
3	Information/message box	<b>BEACON INFO tab:</b> <ul style="list-style-type: none"> <li>• STATION NAME: Always shown as "UNKNOWN".</li> <li>• FREQUENCY: Beacon/station's frequency</li> <li>• STATION HEALTH: Always shown as "Not Available".</li> <li>• SIGNAL QUALITY: SN = Signal to noise ratio (range: 00 dB to 99 dB); SS = Signal strength (range: 00 dB to 99 dB).</li> </ul> <b>Note:</b> Where the value for SN or SS exceeds the maximum displayable value, the indicated value appears as bars ("99dB").
4	[BEACON INFO] / [TYPE16 MESSAGE] tabs	Displays beacon information ([BEACON INFO] tab), or displays received [TYPE16 MESSAGE] messages.

## 2.8 THD Display Mode

THD (Transmitting Heading Device) display mode outputs heading data to external equipment. This display mode has three sub display screens. The default screen is the HDG (heading) data screen. The sub screens, in displayed order, are: ROT (Rate Of Turn) screen → HDG/ROT split screen → THD integrity screen.

Press the **ENT** key to cycle through the display screens.

### 2.8.1 HDG data screen

The HDG data screen shows your current heading and any offset applied to the heading data.

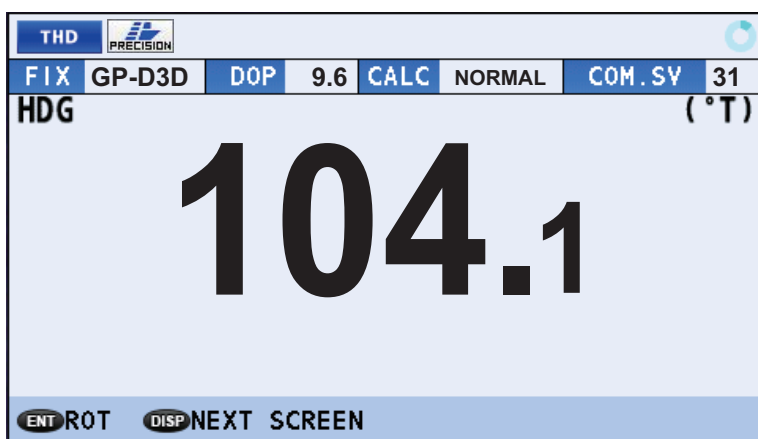

#### How to interpret the THD data display screen

Indication	Description
FIX	Current position fixing method (GP-3D, GP-D3D, etc.)
PDOP	Current DOP (Dilution Of Precision). Displayed as PDOP for positional dilution, HDOP for horizontal dilution.
CALC	Calculation status. <ul style="list-style-type: none"> <li>• [NORMAL]: HDG and ROT are calculated normally.</li> <li>• [DR]: HDG and ROT are calculated using Dead Reckoning.</li> <li>• [STOPPED]: HDG calculation stopped.</li> <li>• [SYS FAULT]: System fault.</li> </ul>
COM. SV	Commonly used satellite's number.

## 2.8.2 ROT data screen

The ROT data screen shows your vessel's current rate of turn.

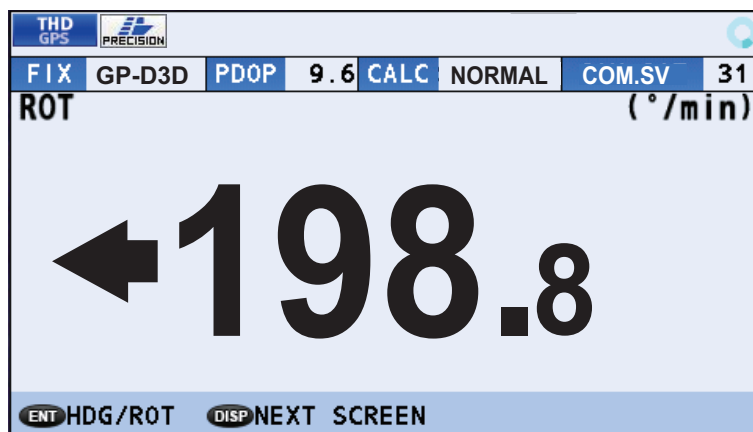

### How to interpret the ROT data screen

Indication	Description
FIX	Current position fixing method (GP-3D, GP-D3D, etc.)
PDOP	Current DOP (Dilution Of Precision). Displayed as PDOP for positional dilution, HDOP for horizontal dilution.
CALC	Calculation status. <ul style="list-style-type: none"> <li>• [NORMAL]: HDG and ROT are calculated normally.</li> <li>• [DR]: HDG and ROT are calculated using Dead Reckoning.</li> <li>• [STOPPED]: HDG calculation stopped.</li> <li>• [SYS FAULT]: System fault.</li> </ul>
COM. SAT	Commonly used satellite's number.

## 2.8.3 HDG/ROT split screen

The HDG/ROT split screen shows heading and rate of turn data with roll/pitch/heave.

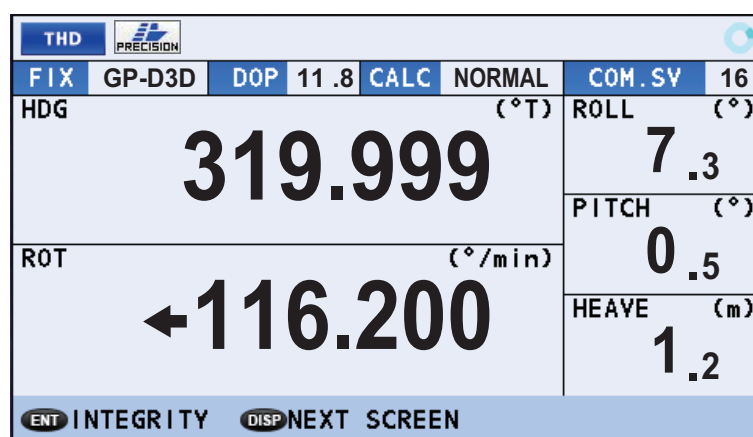

### 2.8.4 THD integrity screen

The THD integrity display shows satellite status and various integrity-related data, as shown in the figure and table below.

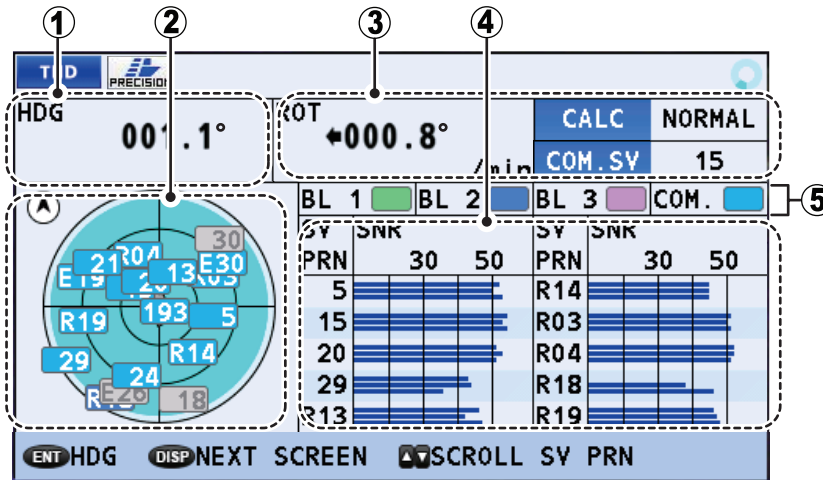

No.	Indication	Description
1	HDG	Current heading.
2	Available satellites	Shows the available satellites and their elevation. Press ► to alternate between North-Up and Head-Up orientations.
3	<ul style="list-style-type: none"> <li>• ROT</li> <li>• CALC</li> <li>• COM. SAT</li> </ul>	<ul style="list-style-type: none"> <li>• Current Rate Of Turn.</li> <li>• Calculation status. (See the table in "HDG data screen" on page 2-10 for details.)</li> <li>• Commonly used satellite's number.</li> </ul>
4	Satellite details	Shows the strength of the signal received from the satellites. More than one bar indicates that more than one antenna is using that satellite. <ul style="list-style-type: none"> <li>• [SV PRN]: Satellite number.</li> <li>• [SNR]: Signal to Noise Ratio.</li> </ul> When more than 10 satellites are in use, press ▲ or ▼ to scroll through the list.
5	Antenna baseline color codes	Shows the color for each antenna baseline in use. The displayed indications are abbreviated as follows: <ul style="list-style-type: none"> <li>• [BL 1] - Antenna No. 1 + Antenna No. 2</li> <li>• [BL 2]* - Antenna No. 2 + Antenna No. 3</li> <li>• [BL 3]* - Antenna No. 3 + Antenna No. 1</li> <li>• COM - Common</li> </ul> *: Shown only when a SC-1303 is connected.

## 2.9 ROTI Display Mode

The ROTI display mode is essentially the same as the THD display mode, in terms of displayed data. However, the following items are displayed in a different manner:

- [DOP] and [FIX] are not shown.
- The indications for [ROT] and [HDG] in the split-screen are reversed.

This display mode has three sub display screens. The default screen is the ROT (Rate Of Turn) data screen. The sub screens, in displayed order, are: HDG (Heading) screen → ROT/HDG split screen → THD integrity screen.

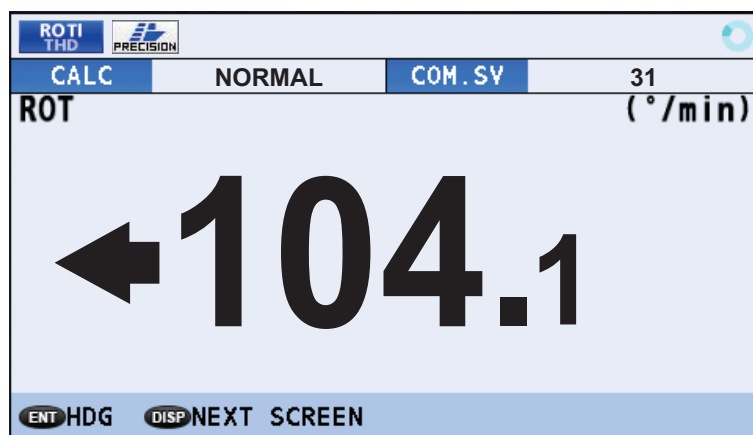

### 2.9.1 ROTI Display for RD-50/RD-20 (option)

For vessels with the optional RD-50/RD-20 installed as part of the SC system configuration, you can show the ROTI data on the RD-50/RD-20 display. See the appropriate operator's manual for details (RD-50: OME-44530-x; RD-20: OME-44540-x; "x" denotes the manual version).

**Note:** For IMO-type vessels, the RD-50 remote display is compatible with IMO regulations. If you use the RD-20 remote display, your vessels no longer meets the IMO requirements.

## 2.10 SPD Display Mode (Non-IMO types only)

The speed and distance data display screen is the default. The sub screen shows navigational data. This display mode is only available for non-IMO types.

### 2.10.1 Speed and distance display screen

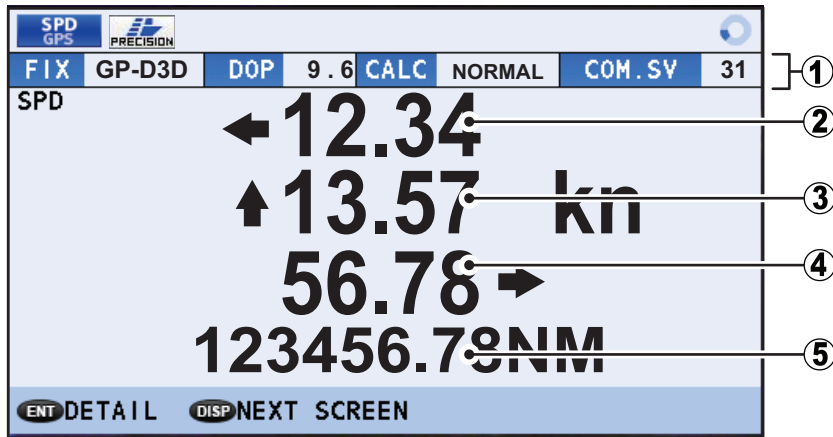

#### How to interpret the speed and distance display screen

No.	Indication	Description
1	[FIX], [DOP], [CALC], [COM.SV]	See section 2.8.1.
2	Lateral bow speed*	Shows the calculated speed at the bow of your vessel. The arrow indicates tendency to port or starboard.
3	Bow to stern speed*	Shows the calculated speed of your vessel. The arrow indicates forward or reverse motion.
4	Lateral stern speed*	Shows the calculated speed at the stern of your vessel. The arrow indicates tendency to port or starboard.
5	Distance traveled	Shows the distance traveled for this trip.

\*: CALC-SPD values must be set at installation to show these speeds. See section 1.6.2 for details.



## 2.10.2 Navigational data screen

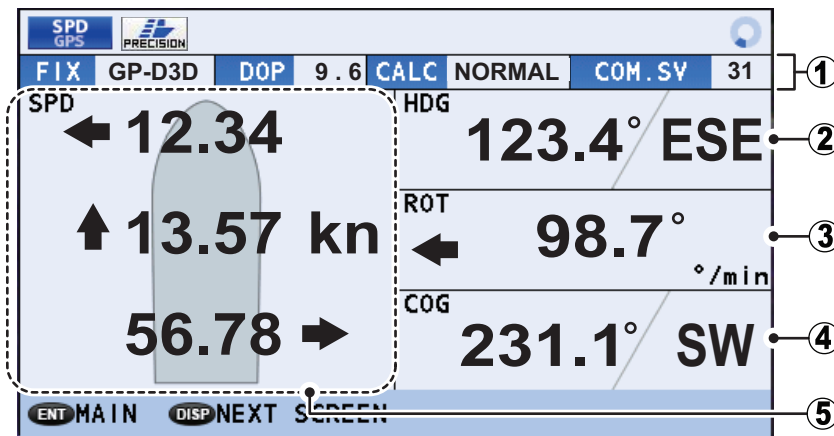

### How to interpret the navigational data

No.	Indication	Description
1	FIX	See section 2.8.1.
2	HDG	Current heading
3	ROT	Rate of turn.
4	COG	Course Over Ground.
5	Speed data	Top line: Lateral bow speed. Middle line: Bow to stern speed. Bottom line: Lateral stern speed.

## 2.11 Alerts

When an alert is triggered, a flashing indication appears at the bottom of the screen and an alert sound is released. The indication shows the alert name, alert code and alert icon.

[Warning] level alerts are shown in yellow-orange color, [Caution] level alerts are shown in yellow color.

### Example alert message (flashing)



The SC-70/SC-130 tracks active (acknowledged but not rectified, or unacknowledged) alerts in the [ALERT LIST] (see section 2.11.3). Alerts which are acknowledged and rectified are saved in the [ALERT LOG] (see section 2.11.4).

For a full list of possible alerts, along with their details such as alert codes and remedies or action required, see "ALERT LIST" on page AP-4.

### 2.11.1 How to acknowledge alerts

There are two methods by which you can acknowledge an alert.

#### **How to acknowledge an alert from the display unit (All alert modes)**

Press the **ACK** key to acknowledge the alert.

#### **How to acknowledge an alert remotely (LEGACY alert mode only)**

The [REMOTE ACK I/F] setting sets the behavior of external equipment which can acknowledge alerts. To use this function, the [ALERT MODE] must be set to [LEGACY] at installation. (Consult your dealer to change this setting.)

To set remote acknowledge, do the following:

1. Open the [MENU].
2. Select [ALERT], then press the **ENT** key.
3. Select [REMOTE ACK I/F], then press the **ENT** key.
4. Select the appropriate setting, then press the **ENT** key.

Setting	Description
[ACK]	External equipment can acknowledge alerts.
[BUZZER STOP]	External equipment can stop aural alerts, but cannot acknowledge alerts.

5. Close the [MENU].

Refer to the operator's manual for the external equipment for alert acknowledgment procedures.

### 2.11.2 How to enable/disable the aural alert (Non-IMO type only)

This setting is only available for non-IMO types.

1. Open the [MENU].
2. Select [ALERT], then press the **ENT** key.
3. Select [SOUND], then press the **ENT** key. An options pop up window appears.
4. Select the appropriate option, then press the **ENT** key.

Option	Description
[OFF]	Disable aural alerts.
[SHORT]	Release two short beeps when an alert is triggered.
[LONG]	Release three long beeps when an alert is triggered.
[CONTINUOUS]	Release a continuous beep when an alert is triggered.

5. Close the [MENU].

### 2.11.3 How to access the alert list

The alert list shows all currently violated alerts and state of acknowledgment.

All unacknowledged alerts are shown, even those whose reason for the alert has been rectified or passed (except for cautions). To access the alert list, do the following:

1. Open the [MENU].
2. Select [ALERT], then press the **ENT** key.
3. Select [ALERT LIST], then press the **ENT** key. The list of active alerts appears.

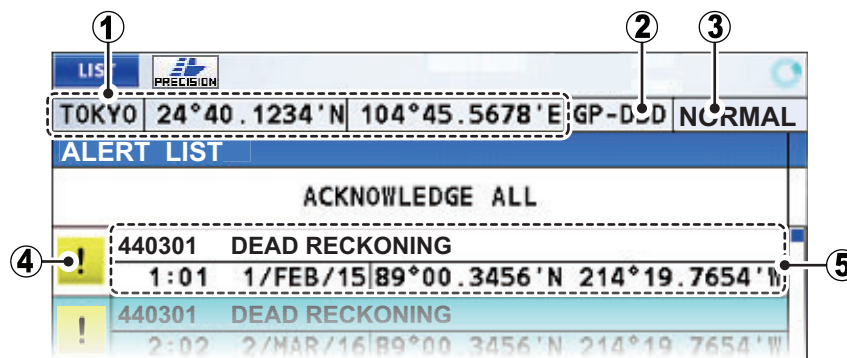

4. Press **▲** or **▼** to scroll up or down through the alert log.
5. Press the **DISP** key to close the [ALERT LIST].

**Note:** You can also access the [ALERT LIST] from the [LIST] display. Press the **LIST** key to cycle through the lists.

#### How to interpret the alert list

No.	Indication name	Description
1	DATUM/OS coordinates or [HDG]/[ROT]	<p>Where the device mode is [THD] or [ROT]:</p> <ul style="list-style-type: none"> <li>• [HDG]: OS heading, oriented to North. If the heading data is received from an external device, the device name and external input talker are shown.</li> <li>• [ROT]: Rate of turn with arrow indicating turn direction to port or starboard.</li> </ul> <p>Where the device mode is [SPD] or [GPS]: Datum and OS coordinates are displayed.</p>
2	FIX	Current position fixing method (GP-3D, GP-D3D, etc.)
3	CALC	<p>Calculation status.</p> <ul style="list-style-type: none"> <li>• [NORMAL]: Data is calculated normally.</li> <li>• [DR]: Data is calculated using Dead Reckoning.</li> <li>• [STOPPED]: Data calculation stopped.</li> <li>• [SYS FAULT]: System fault.</li> </ul>
4	Alert icon	Shows alert status. See page AP-8 for details.
5	Alert details	<p>Top line: alert code, alert message Bottom line: time of alert, coordinates at time of alert.</p> <p><b>Note:</b> A full list of alert codes, meaning and measure is included at "ALERT LIST" on page AP-4.</p>

### 2.11.4 How to access the alert log

The alert log shows the latest 50 alerts. When the log becomes full, the oldest entry is erased to make room for current alerts. To access the alert log, do the following:

1. Open the [MENU].
2. Select [ALERT], then press the **ENT** key.
3. Select [ALERT LOG], then press the **ENT** key.

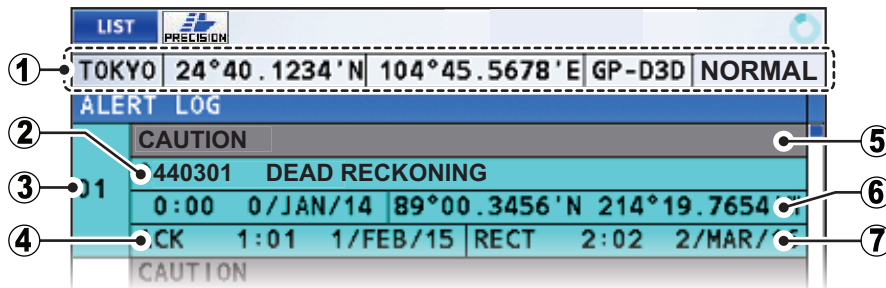

4. Press **▲** or **▼** to scroll up or down through the alert log.
5. Press the **DISP** key to close the [ALERT LOG].

**Note:** The [ALERT LOG] can also be accessed from the [LIST] display. Press the **LIST** key to cycle through the lists.

#### How to interpret the alert log

No.	Indication name	Description
1	DATUM, OS coordinates, Calculation status, [HDG], [ROT]	See section 2.11.3.
2	Alert code and message	Alert code appears in six digit format. <b>Note:</b> A full list of alert codes, meaning and measure is included at "ALERT LIST" on page AP-4.
3	Alert number	Number assigned to the selected alert by the alert log. Up to 50 alerts are stored. <b>Note:</b> This is not an alert code.
4	[ACK]	Time and date the alert was acknowledged.
5	Alert priority	The priority level assigned to the selected alert. Displayed as "WARNING" or "CAUTION".
6	Alert time / coordinates	Time of alert, coordinates at time of alert.
7	[RECT]	Time and date alert was rectified.

## 2.12 How to View the Connected Devices

The [DEVICE LIST] shows up to 51 devices connected to the same CANbus network. You can also view details for each displayed device.

To view the [DEVICE LIST], press the **LIST** button to cycle through the [LIST] screens.

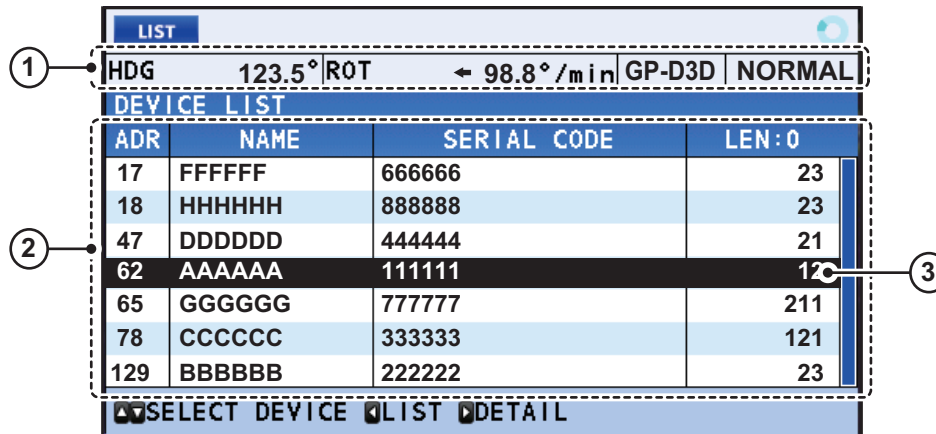

**Note:** The [DEVICE LIST] is updated each time it is accessed. If a device is added to the network while the [DEVICE LIST] is open, close, then re-open the [DEVICE LIST] to show the newly added device.

### How to interpret the device list

No.	Indication name	Description
1	DATUM, OS coordinates, Calculation status, [HDG], [ROT]	See section 2.11.3.
2	[ADR]	CANbus network address (0 to 255). Devices are listed in numerical order.
	[NAME]	CAN Device name.
	[SERIAL CODE]	CAN device's address claim.
	[LEN]	CAN device's LEN (Load Equivalency Number).
3	Selected item (highlighted)	Press ▼ or ▲ to scroll through the device list.

### How to interpret device details

Select the device whose details you want to view, then press ►. The device details appears at the center of the screen.

INFORMATION	
ProductCode	Sample Data
UniqueNumber	12321
SoftwareVersionCode	12345678901234567890123456
ModeID	12345678901234567890123456789012

Selected device's unique CAN number

Selected device's mode ID

Selected device's code

Selected device's software version

## 2.13 DISPLAY Menu

You can customize the manner in which most items are displayed on your screen, from the [DISPLAY] menu.

Press the **MENU ESC** key, select [DISPLAY], then press the **ENT** key to show the [DISPLAY] menu.

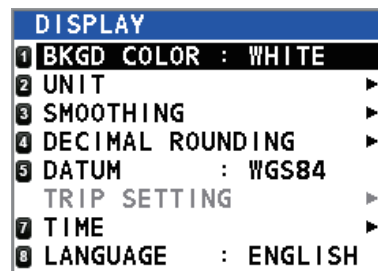

### 2.13.1 How To Change the Display Color

You can change the background and text color for better visibility. There are two options, White background and Black background.



The color change can be made using of the two following methods:

#### How to change the color from the menu

1. Open the [DISPLAY] menu.
2. Select [BKGD COLOR], then press the **ENT** key.
3. Select [BLACK] or [WHITE] as appropriate, then press the **ENT** key.
4. Close the [MENU].

#### How to change the color from the controls

See section 2.3.2 for details.

### 2.13.2 How to Change the Units of Measurement

To change the unit of measurement for distance, follow the procedure below.

1. Open the [DISPLAY] menu.
2. Select [UNIT], then press the **ENT** key.
3. [DISTANCE] is selected, press the **ENT** key.
4. Select the appropriate distance unit, then press the **ENT** key.

**Note:** The unit of measurement for speed is also changed, as shown below

- [NM]: Nautical Miles - speed shown as [kn].
- [KM]: Kilometers - speed shown as [km/h].
- [SM]: Statute Miles - speed shown as [mph].

5. Close the [MENU].

### 2.13.3 How To Use The Smoothing Menu

Data received from external sensors can be smoothed. This helps to reduce variations caused by unfavorable receiving conditions or other factors.

1. Open the [DISPLAY] menu.
2. Select [SMOOTHING], then press the **ENT** key.
3. Select the appropriate item to smooth, then press the **ENT** key.

Menu item	Description	Setting range
VTG	Course over ground, ground speed	0000 s to 9999 s
6DoF	Six Degrees of Freedom - Roll/Pitch	0000 s to 9999 s
OS SPEED (X,Y)	Dual water/ground speed	0000 s to 9999 s <b>Note:</b> Available for non-IMO types only.
ROT	Rate of turn	00 s to 30 s

4. Close the [MENU].

To disable smoothing for any of the above menu items, repeat the above procedure, then set the smoothing value to [0] (zero).

### 2.13.4 How to set the number of digits after a decimal point

To change the number of digits displayed after a decimal point, follow the procedure below. Up to three digits can be set.

1. Open the [DISPLAY] menu.
2. Select [DECIMAL ROUNDING], then press the **ENT** key.
3. Select the appropriate item, then press the **ENT** key.

Item	Affected indications
[VTG]	Speed indications which use the VTG sentence for data input.
[VBW]	Speed indications which use the VBW sentence for data input.
[HDG]	All heading indications. ([ROT] is also affected, see section 2.8.2.)
[ROLL, PITCH]	All roll/pitch indications. ([HEAVE] is also affected, see section 2.8.3.)

4. Select [1], [2] or [3] as appropriate, then press the **ENT** key.
  - [1]: Values are displayed with one digit after the decimal point. The values are also rounded up or down as appropriate.
  - [2]: Values are displayed with two digits after the decimal point. The values are also rounded up or down as appropriate.
  - [3]: Values are displayed with three digits after the decimal point. The values are also rounded up or down as appropriate.

**Note:** This setting also affects serial output data, sent to other equipment.

5. Close the [MENU].

### 2.13.5 How to Set Geodetic Data

The SC-70/SC-130 uses the WGS84 datum as the default geodetic datum. To change the datum used, follow the procedure below.

1. Open the [DISPLAY] menu.
2. Select [DATUM], then press the **ENT** key.
3. Select the appropriate datum, then press the **ENT** key. The available selections are: [WGS84], [WGS72], [PZ90], [CK42], [CK95] and [OTHERS].  
If the datum you wish to use is not displayed, select [OTHERS].
4. If you selected [OTHERS], proceed to step 5. For all other selections, close the menu.
5. Input the chart number, referring to the geodetic chart list at the back of this manual, then press the **ENT** key.
6. Close the [MENU].

### 2.13.6 How to Reset the Trip Meter

The trip meter calculates the distance your vessel has traveled and can be restarted at any time. This menu is not available for IMO types.

To reset the trip meter, do the following:

1. Open the [DISPLAY] menu.
2. Select [TRIP SETTING], then press the **ENT** key.
3. [CLEAR] is already selected. Press the **ENT** key to reset the meter.
4. Close the [MENU].

### 2.13.7 How to Adjust the Date and Time

The SC-70/SC-130 can display the date and time in UTC format or as the local (geographical) time. You can also set for summer time. To adjust time settings, refer to the appropriate topic below.

#### **How to change the time display format**

1. Open the [DISPLAY] menu.
2. Select [TIME], then press the **ENT** key.
3. Select [LOCAL TIME], then press the **ENT** key.
4. Select [UTC] or [LOCAL] as appropriate, then press the **ENT** key.

Setting	Remarks
[UTC]	UTC (Coordinated Universal Time) time is calculated automatically.
[LOCAL]	Manually input the time offset (based on UTC time).

5. Close the [MENU].



### How to enable/disable summer time

You can manually adjust the time to reflect summer (daylight saving) time.

1. Open the [DISPLAY] menu.
2. Select [TIME], then press the **ENT** key.
3. Select [SUMMER TIME], then press the **ENT** key.
4. Select [ON] to enable summer time, [OFF] to disable summer time.
5. Close the [MENU].

## 2.13.8 How to Set the Display Language

The SC-70/SC-130 can display menus and data in English or Japanese. If the display language has been changed to Japanese, do the following to change the language back to English.

**Note:** This procedure uses the menu item numbers which are displayed at the left-side of each menu.

1. Open the [MENU].
2. Select [1], then press the **ENT** key.
3. Select [8], then press the **ENT** key.
4. Select [ENGLISH], then press the **ENT** key.
5. Close the [MENU].

## 2.14 GNSS Menu

You can adjust various GNSS-related settings from the [GNSS] menu.

Press the **MENU ESC** key, select [GNSS], then press the **ENT** key to show the [GNSS] menu.

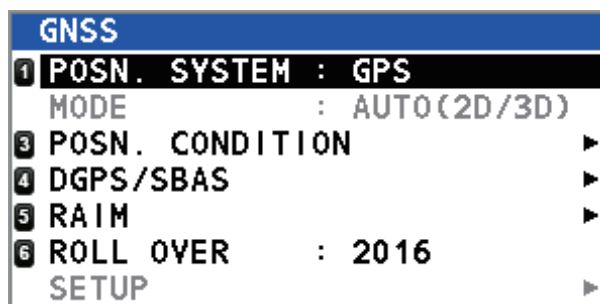

### 2.14.1 How to select the positioning system to use

1. Open the [GNSS] menu.
2. Select [POSN. SYSTEM], then press the **ENT** key.
3. Select the appropriate positioning system, then press the **ENT** key.

**Note:** At the time of printing, only [GPS] is available for selection. Other positioning system may be added at a later date.

4. Close the [MENU].

### 2.14.2 How to set the positioning conditions

1. Open the [GNSS] menu.
2. Select [POSN. CONDITION], then press the **ENT** key.
3. Referring to the table below, set the conditions for position fixing, then press the **ENT** key.

Menu item	Options	Remarks
QZSS	<ul style="list-style-type: none"> <li>• [OFF]</li> <li>• [ON] (default)</li> </ul>	Enable/disable the use of the QZSS system.
ELEVATION MASK	For technical personnel only. Not changeable.	
IGNORED GNSS	[000] to [999]	<p>The system uses the on-board almanac to ignore satellites which are known to provide incorrect data. However, some of these satellites may not be registered in the almanac. You can add satellites to be ignored using this function.</p> <ol style="list-style-type: none"> <li>1) Select the satellite network to which the satellite you want to ignore is registered. The [IGNORED SATELLITE] window appears.</li> <li>2) Enter the satellite number to be ignored. You can enter up to 3 satellites per network. Press ▲ to increase the value, ▼ to decrease the value and press ► or ◀ to move the input cursor.</li> </ol> <div style="display: flex; align-items: center; justify-content: center;"> <div style="border: 1px solid black; padding: 5px; margin-right: 10px;"> <p style="text-align: center; margin: 0;">IGNORED GNSS</p> <p style="margin: 0;">1 QZSS</p> <p style="margin: 0;">2 GPS</p> <p style="margin: 0;">3 GLONASS</p> <p style="margin: 0;">4 GALILEO</p> </div> <div style="font-size: 2em; margin-right: 10px;">➔</div> <div style="border: 1px solid black; padding: 5px; margin-left: 10px;"> <p style="text-align: center; margin: 0;">IGNORED SATELLITE</p> <p style="text-align: center; margin: 0;">▲ 000 ▼</p> <p style="text-align: center; margin: 0;">000</p> <p style="text-align: center; margin: 0;">000</p> <p style="text-align: center; margin: 0;">ENTER CANCEL</p> </div> </div> <ol style="list-style-type: none"> <li>3) Select [ENTER], then press the <b>ENT</b> key.</li> </ol>

4. Close the [MENU].

### 2.14.3 How to Set Up DGPS/SBAS

The SC-70/SC-130 can connect to DGPS beacons or SBAS (Satellite Based Augmentation Systems) to refine position fixing.

#### How to select the mode of refinement

- 1) Open the [GNSS] menu.
- 2) Select [DGPS/SBAS], then press the **ENT** key.
- 3) Select [DIFFERENTIAL], then press the **ENT** key.
- 4) Referring to the list below, select the appropriate mode, then press the **ENT** key.
  - [GNSS]: No position refinement used.
  - [GNSS+SBAS]: Use SBAS to refine position fixing.
  - [GNSS+EXTERNAL]: Use beacons to refine position fixing.  
**Note:** The [MODE] setting for [DATA5] in the [I/O] menu must be set to [RTCM] to enable this mode.
  - [AUTO]: The SC-70/SC-130 automatically switches modes as required.  
 The priority is: [EXTERNAL] > [SBAS] > [GNSS].
- 5) Close the [MENU].

#### How to search for available SBAS

- 1) Open the [GNSS] menu.
- 2) Select [DGPS/SBAS], then press the **ENT** key.
- 3) Select [SBAS SEARCH], then press the **ENT** key.
- 4) Select [AUTO] or [MANUAL] as appropriate, then press the **ENT** key.
  - [AUTO] selects the highest elevated satellite available.
  - [MANUAL] requires the manual input of the three-digit satellite number.
- 5) Close the [MENU].

#### How to ignore SBAS satellites

- 1) Open the [GNSS] menu.
- 2) Select [DGPS/SBAS], then press the **ENT** key.
- 3) Select [IGNORED SBAS], then press the **ENT** key.
- 4) Enter the satellite number to be ignored. You can enter up to 3 satellites per network. Press **▲** to increase the value, **▼** to decrease the value and press **▶** or **◀** to move the input cursor.
- 5) Close the [MENU].

#### How to select the DGPS beacon

- 1) Open the [GNSS] menu.
- 2) Select [DGPS/SBAS], then press the **ENT** key.
- 3) Select [BEACON SETUP], then press the **ENT** key.
- 4) Select [AUTO] or [MANUAL], then press the **ENT** key.
  - [AUTO]: The SC-70/SC-130 automatically select the beacon to use.
  - [MANUAL]: Manually input the beacon frequency and bit rate.
- 5) Close the [MENU].

### 2.14.4 How to Set Up RAIM

RAIM (Receiver Autonomous Integrity Monitoring) is a diagnostic feature which tests the integrity (accuracy) of the position fixing signal.

The receiver estimates position confidence using range value and detected satellite error, and displays (provided the RAIM function is active) the results as one of three levels of position confidence in the text data box of the GPS display mode only. The three levels are as follows:

- [SAFE]: GPS signal is normal. The positioning accuracy satisfies the setting value.
- [CAUTION]: RAIM accuracy cannot be calculated. (Signals from five or more GPS satellites are necessary for calculation.) The positioning accuracy does not satisfy the setting value.
- [UNSAFE]: GPS signal is abnormal, therefore the positioning accuracy is not reliable.

To use the RAIM feature, do the following:

1. Open the [GNSS] menu.
2. Select [RAIM], then press the **ENT** key.
3. Select [RAIM FOR GPS], then press the **ENT** key.
4. Select [SETTING], then press the **ENT** key. An options pop up window appears.
5. Select [ON] to enable the RAIM feature, select [OFF] to disable the RAIM feature.
6. Select [ACCURACY LEVEL], then press the **ENT** key. A numerical input pop up window appears.
7. Set the compensation for RAIM accuracy.
8. Select [ENTER], then press the **ENT** key to apply the RAIM settings, or select [CANCEL] then press the **ENT** key ignore the settings changes.
9. Close the [MENU].

### 2.14.5 How to set the rollover timing

The SC-70/SC-130 uses the positioning system to calculate date and time. Date and time data sent via satellite signal is reset once every few years, which can cause problems in date/time display. The rollover is used to prevent this from occurring. By setting the correct year on your SC-70/SC-130, the satellites and your system become synchronized.

1. Open the [GNSS] menu.
2. Select [RAIM], then press the **ENT** key.
3. Select [ROLL OVER], then press the **ENT** key. The [INPUT ROLL OVER] window appears.
4. Enter the current year.  
Press ▲ to increase the value, ▼ to decrease the value and press ► or ◀ to move the input cursor.
5. Select [ENTER] to apply the new setting, select [CANCEL] to keep the current setting.  
If you select [ENTER], a confirmation window appears. Select [YES] to confirm and restart the system with the new setting.

## 2.15 How to Set Up the I/O Menu

Besides its fundamental function of displaying position, the SC-70/SC-130 can also output various data to external equipment. Before outputting data to external equipment, first determine what data the external equipment requires. Only the necessary data should be output, to ensure that the data will be output correctly.

All data transmitted by marine electronics equipment are prefixed with a two character code, known as a “talker”. The same talker must be shared by the transmitting and receiving equipment to transmit and receive data successfully.

### 2.15.1 How to set up serial data output

The SC-70/SC-130 has five serial data ports which can be set up for data output.

To set up more than one port, repeat the procedure below as necessary.

1. Open the [MENU].
2. Select [I/O], then press the **ENT** key.
3. Select [DATA 1], or the appropriate data port, then press the **ENT** key.
4. Select [DATA OUTPUT], then press the **ENT** key. An options pop up window appears.
5. Select [IEC/NMEA] or [RTCM] as appropriate, then press the **ENT** key.  
[IEC/NMEA]: Output data in NMEA format.  
[RTCM]: Output data in binary format.  
**Note:** [RTCM] can only be selected as the mode of output at [DATA 5], all other ports display [RTCM] in gray color and [RTCM] is not selectable.
6. For non-IMO vessels only, select [OUTPUT FORMAT], then press the **ENT** key. An options pop up window appears.  
For IMO type vessels, go to step 12. [OUTPUT FORMAT] and [BAUD RATE] are fixed for IMO type vessels.
7. Select the appropriate port output format, then press the **ENT** key. The available options are: [IEC61162-1ED.4], [IEC61162-1ED.3], [NMEA V2.0], [NMEA V1.5].
8. Select [TALKER], then press the **ENT** key. An options pop up window appears.
9. Select the appropriate talker, then press the **ENT** key. The available options are listed in the table below with a brief description.

Talker	Description	Talker	Description
GN	Mixed GPS and GLONASS	GP	GPS
HE	Heading - North seeking gyrocompass	GL	GLONASS
HN	Heading - Non-north seeking gyrocompass	GA	Galileo
HC	Heading - Magnetic compass		

**Note:** For IMO-types, the talkers are fixed as follows.

THD, ROTI device mode : Fixed at [HE].  
GPS device mode : Fixed at [GP].

10. Select [BAUD RATE], then press the **ENT** key. An options pop up window appears.
11. Select the appropriate baud rate for data transfer, then press the **ENT** key.

## 2. OPERATION

12. Select [SENTENCES], then press the **ENT** key. The sentence setup window appears.

13. Press the arrow keys to move the selection cursor and highlight the sentence to set up, then press the **ENT** key. The cycle section of the sentence is now highlighted.

14. Press ◀ or ▶ to adjust the sentence output cycle, then press the **ENT** key.

15. To set up other sentences, repeat steps 13 and 14 as necessary.

**Note:** The sentence load rate indicates the workload required to process the sentences. When setting sentences, observe the load rate carefully and ensure it does not reach or exceed 100%.

16. To apply the changes, select [ENTER], at the bottom of the sentence list, then press the **ENT** key.

To cancel any changes to the sentences, select [CANCEL], then press the **ENT** key.

17. Close the [MENU].

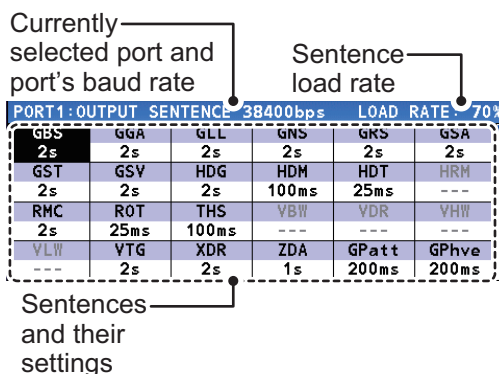

### 2.15.2 How to set up LAN data output

When connecting the SC-70/SC-130 to a shipboard LAN network, perform the following procedure to set up data output.

1. Open the [MENU].

2. Select [I/O], then press the **ENT** key.

3. Select [NETWORK], then press the **ENT** key.

4. For non-IMO vessels, select [TALKER], then press the **ENT** key.

An options pop up window appears.

For IMO-type vessels, go to step 6.

5. Select the appropriate talker, then press the **ENT** key. The available options are listed in the table at step 9 of section 2.15.1.

**Note:** For IMO-types, the talkers are fixed as follows.

THD, ROTI device mode : Fixed at [HE].

GPS device mode : Fixed at [GP].

6. Referring to steps 12 through 15 of section 2.15.1, set up the sentences as appropriate.

7. Select [IP ADDRESS/PORT], then press the **ENT** key. A numerical pop up window appears.

Use the following IP Address and Port combinations to show the log data in the [ETHERNET] log:

IP Address	Port	IP Address	Port
239.192.000.001	60001	239.192.000.004	60004
239.192.000.003	60003	239.192.000.008	60008

8. Set the IP address and port as appropriate, select [ENTER], then press the **ENT** key.

9. Close the [MENU].

### 2.15.3 How to set up data sources (data input)

1. Open the [MENU].
2. Select [I/O], then press the **ENT** key.
3. Select [DATA SOURCE], then press the **ENT** key.
4. Select [HDG] (Heading) or [EXT. STW] (External Speed Thru Water), then press the **ENT** key. An options pop up window appears.
5. Referring to the table below, set the appropriate data source for [HDG] or [EXT. STW].

Menu option	Description
[INTERNAL LAN]*	Use the SC-70/SC-130 antenna as the data source. This is the default setting.
[DATA 1] to [DATA 5]	Select the serial port for position data input from an external source.
[USER PRIORITY]	<p>Set the priority for serial ports. If the signal from a port is interrupted, the SC-70/SC-130 automatically switches to the next available port (sensor), in priority order.</p> <p>The port numbers are listed on the left-side of the window.</p> <p>The priority settings, at the right-side of the window, show the highest priority sensor to the left, and the lowest priority sensor to the right.</p> <p>In the example figure, the priority order is set as follows: 1→6→4→2→5→3.</p> <p><b>Note:</b> [1: INTERNAL LAN] is fixed as the highest priority data source.</p>

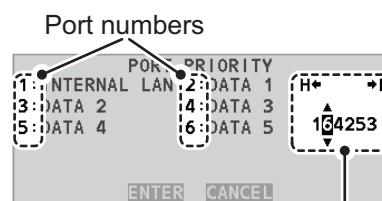

#### Priority settings

Press ▲ or ▼ to change port.  
Press ◀ or ▶ to move the cursor.

\*: The [INTERNAL LAN] menu option is not available for [EXT. STW].

6. Close the [MENU].

### 2.15.4 How to use the input/output logs

The [I/O LOGS] display logged data for input/output information for serial ports and LAN connections. You can export the logged data to an external flash memory.

The following keys have specific functions when a log screen appears.

Key	Function
◀	Close the log and return to the [I/O] menu.
▲ or ▼	Toggle input and output log displays.
ENT	Press with external flash memory connected: start/pause saving the log.
MENU ESC	Close the logs and the [I/O] menu.

Saved log files are automatically named in the following format:

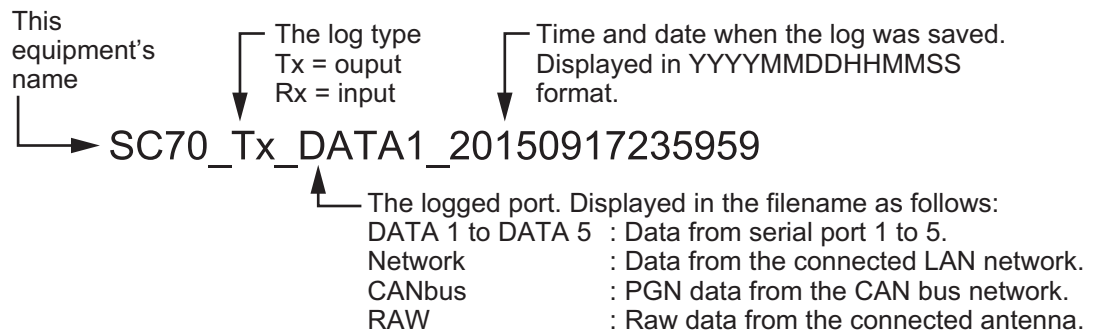

The log data which can be saved depends on the monitor type selected.

#### [DATA1] to [DATA5] - Serial data

Selected port and port's baud rate → SERIAL DATA: 1 38400bps

Currently displayed data  
TX = Output data  
RX = Input data → TX

USB status  
No USB = No external flash memory connected.  
SAVING = Saving log data to external flash memory.  
STOP SAVING = Flash memory connected, no log data currently being saved.

Logged input/output data is displayed here.



**[ETHERNET] - LAN data**

**Note:** If the IP address & port combination is not a recognized combination (see section 2.15.2), the [ETHERNET] log screen appears blank.

Data source's IP address      Destination broadcast address and port

MENU	PRECISION			
HDG	01.495°	ROT	+0(0.858° /min)	GP-S3D NORMAL
IEC 6	162-450			NO USB
1	172.31.18.22	→ SATD(239.192.0.3:60003)		
	\s:HE0002,n:258*01\SHETHS,180.5,A*21<0D><0A>			
2	172.31.18.22	→ SATD(239.192.0.3:60003)		
	\s:HE0002,n:259*00\SPFEC,GPatt,180.5,-2.2,-23.4*71<0D><0A>			
3	172.31.18.22	→ SATD(239.192.0.3:60003)		
	\s:HE0002,n:260*0A\SPFEC,GPhve,0.024,A*39<0D><0A>			
SHOW DETAIL   BACK   MENU/CLOSE   (ENT) LONG   REFRESH				

Packet summary  
Press ▲ or ▼ to select a packet. Selection is highlighted in gray.

Select a packet, then press ► to view the packet details.

MENU	PRECISION			
HDG	002.320°	ROT	+000.816° /min	GP-S3D NORMAL
172.31.18.22 → SATD(239.192.0.3:60003)				
\s:HE0002,n:869*09\SHEHDT,181.7,T*20<0D><0A>				
SHOW DETAIL   BACK   MENU/CLOSE   (ENT) LONG   REFRESH				

**[CAN] - CAN Bus network data**

PGN destination's CAN address (broadcast to 255)

PGN source's unique CAN address

CAN SRC	BUS DST	PGN	PGN name	NO USB
000	255	127251	Rate of Turn	
000	255	127252	Heave	
000	255	127257	Attitude	
000	255	127258	Magnetic Variation	
000	255	129025	Position	
000	255	129026	COG & SOG Rapid Update	
000	255	129029	GNSS Position Date	
SHOW DETAIL INFORMATION   BACK   MENU/CLOSE				

USB status  
**No USB** = No external flash memory connected.  
**SAVING** = Saving log data to external flash memory.  
**STOP SAVING** = Flash memory connected, no log data currently being saved.

Select a PGN, then press ► to view the PGN details.

PGN and name	PGN details
60928 ISO Address Claim	Unique Number : 1
	Manufacture Code : 1855
	Device Instance Lower : 1
	Device Instance Upper : 1
	Device Function : 1
	Reserved : -
	Device Class : 1
	System Instance : 1
SHOW DETAIL INFORMATION   BACK   MENU/CLOSE	

**[LAN ERROR LOG]**

The [LAN ERROR LOG] counts LAN errors, filing the errors in one of six error groups. The table below shows the error groups along with possible causes for their errors.

LAN ERROR COUNTER		
1	INCORRECT SENTENCE	0
2	TAG BLOCK FRAMING ERROR	0
3	TAG SYNTAX ERROR	0
4	TAG BLOCK CHECKSUM ERROR	0
5	INCORRECT TAG BLOCK	0
6	INVALID HEADER	0

Error	Possible cause(s)
[INCORRECT SENTENCE]	<ul style="list-style-type: none"> <li>• Sentence in TAG block has an error.</li> <li>• CHECKSUM error.</li> <li>• Sentence does not meet NMEA0183 standards.</li> </ul>
[TAG BLOCK FRAMING ERROR]	Unexpected transmission start/stop in TAG block.
[TAG SYNTAX ERROR]	<ul style="list-style-type: none"> <li>• One or more errors in TAG block.</li> <li>• Data length is too long or too short.</li> <li>• Delimiter is in use.</li> <li>• Use of incorrect characters.</li> </ul>
[TAG BLOCK CHECKSUM ERROR]	TAG block has one or more CHECKSUM errors.
[INCORRECT TAG BLOCK]	One or more instances of the following: <ul style="list-style-type: none"> <li>• Incorrect talker used.</li> <li>• Incorrect SFI used.</li> <li>• Incorrect parameters (g, s, p, n, t) used.</li> </ul>
[INVALID HEADER]	One or more instances where the following are not included: <ul style="list-style-type: none"> <li>• UdPbC</li> <li>• RaUdP</li> <li>• RrUdP</li> </ul>

Press and hold the **ENT** key to clear the [LAN ERROR LOG].

### 2.15.5 How to restart heading output

In cases where the heading signal is lost or interrupted, the SC-70/SC-130 can restart signal output. There are two methods, [AUTO] and [MANUAL].

1. Open the [MENU].
2. Select [I/O], then press the **ENT** key.
3. Select [MISCELLANEOUS], then press the **ENT** key.
4. Select [HDG OUTPUT RESTART], then press the **ENT** key. An options pop up window appears.
5. Select [AUTO] or [MANUAL] as appropriate, then press the **ENT** key.

[AUTO] : Automatically restart heading output when the signal is restored.

[MANUAL] : When the heading signal is lost, an alert message and audible alert are released. If the heading signal output is restored, the message "HDG DATA OUTPUT HAS BEEN RESTARTED." is shown. Press the **ENT** key to resume the signal output.

**Note:** The default setting is [AUTO]. Select [MANUAL] depending on connected equipment.

6. Close the [MENU].

### 2.15.6 How to change the speed reference (Non-IMO types only)

The speed reference is used in the VHW sentence for speed data output to external equipment.

1. Open the [MENU].
2. Select [I/O], then press the **ENT** key.
3. Select [MISCELLANEOUS], then press the **ENT** key.
4. Select [STW] (Speed Through Water), then press the **ENT** key. An options pop up window appears.
5. Select [VECTOR] or [SCALAR] as appropriate, then press the **ENT** key.
  - [VECTOR] : Speed is calculated based on own ship vector.
  - [SCALAR] : Speed is calculated based on SOG (Speed Over Ground).
6. Close the [MENU].

## 2.16 SENSOR Menu

The [SENSOR] menu contains settings for the connected sensors. Some settings in this menu require service level access and are not changeable by the user.

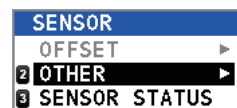

To access this menu, open the [MENU], then select [SENSOR].

**Note:** The [OFFSET] menu is reserved for technical personnel only.

### 2.16.1 OTHER menu

1. Open the [MENU].
2. Select [SENSOR], then press the **ENT** key.
3. Select [OTHER], then press the **ENT** key.

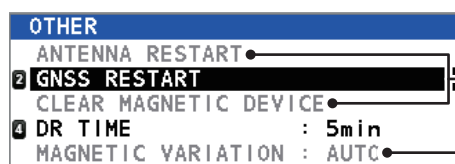

For technical personnel only

Not available for IMO types

4. Select the appropriate menu item, then press the **ENT** key.
  - [GNSS RESTART]: Restarts the GNSS cores. A confirmation message appears; select [YES] to reset the GNSS cores or select [NO] to cancel the reset.
  - [DR TIME]: Set the Dead Reckoning time. Available options are [1 min], [2 min], [3 min], [4 min] and [5 min] (default setting). Select the required time, then press the **ENT** key.
  - [MAGNETIC VARIATION]: Select whether to adjust for magnetic variation automatically ([AUTO]) or manually ([MANUAL]). If you selected [MANUAL], the [INPUT MAGNETIC VARIATION] pop up window appears. Enter the variation amount, select [ENTER], then press the **ENT** key.

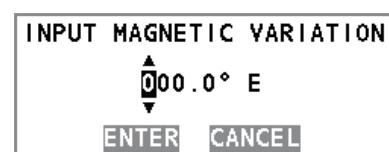

**Note:** The [MAGNETIC VARIATION] menu item is not available for IMO types.

5. Close the [MENU].

### 2.16.2 SENSOR STATUS menu

You can check the status of your sensors from this menu. Select [SENSOR STATUS] from the [SENSOR] menu to show the window below.

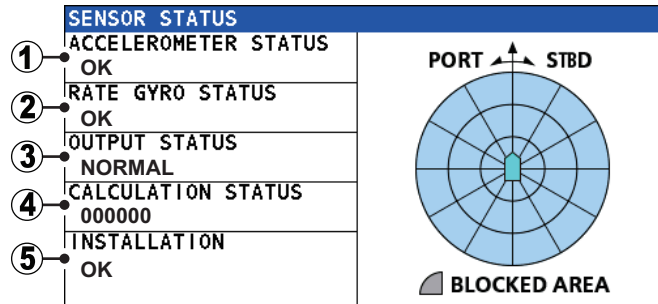

Possible statuses for each item are listed in the table below.

No.	Possible status
1	<ul style="list-style-type: none"> <li>"OK": Sensor is functioning normally.</li> <li>"NG (axis)": The sensor is not functioning normally on the axis shown. For example, "NG X,Y" means the X and Y axis are not functioning normally.</li> </ul>
2	<ul style="list-style-type: none"> <li>"OK": Sensor is functioning normally.</li> <li>"NG (axis)": The sensor is not functioning normally on the axis shown. For example, "NG X,Y" means the X and Y axis are not functioning normally.</li> </ul>
3	<ul style="list-style-type: none"> <li>"NORMAL": Sensor is functioning normally.</li> <li>"DR": Dead Reckoning in use.</li> <li>"OUTPUT STOPPED": Sensor output has stopped.</li> <li>"NOT EXPECTED": An unexpected error has occurred.</li> </ul>
4	Hexadecimal code is displayed.
5	<ul style="list-style-type: none"> <li>"OK": Sensor is functioning normally.</li> <li>"BLOCKED": One or more sensors' line of view is blocked.</li> <li>"VIBRATED": One or more sensors are in a location which is subject to excessive vibrations.</li> </ul>

### 2.17 SYSTEM Menu

The SYSTEM menu contains settings for your SC-70/ SC-130 system. To access this menu, open the [MENU] then select [SYSTEM].

**Note 1:** The [USB FLASH DRIVE] menu item is selectable only when a USB Flash Memory is connected to the Junction Box.

**Note 2:** The [NETWORK] menu item is reserved for technical personnel only and require password level access from the [SERVICE] menu.

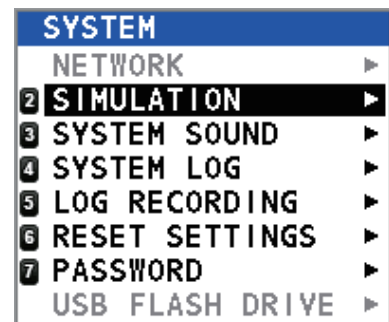

## 2.17.1 Simulation mode

Simulation mode uses data from the internal memory to provide a simulation of the systems functions. To use the simulation mode, several settings are required, as listed in the procedure below.

1. Open the [MENU].
2. Select [SYSTEM], then press the **ENT** key.
3. Select [SIMULATION], then press the **ENT** key.

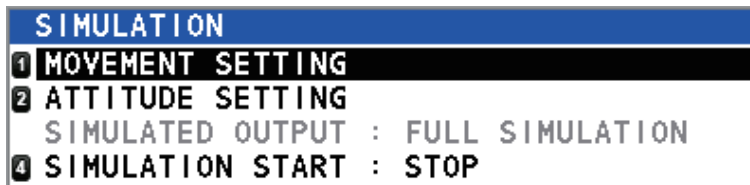

4. Select [MOVEMENT SETTING], then press the **ENT** key. The [SIMULATION(MOVEMENT) SETTING] window appears.

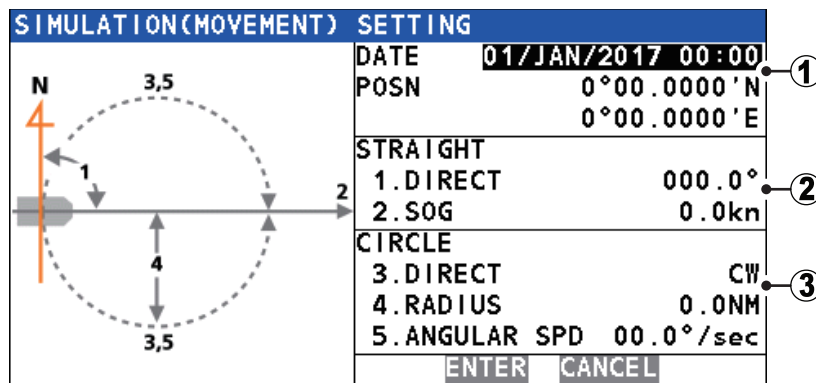

No.	Menu item	Description
1	<ul style="list-style-type: none"> <li>• [DATE]</li> <li>• [POSN]</li> </ul>	<ul style="list-style-type: none"> <li>• Sets the date for the simulation.</li> <li>• Sets the position (coordinates) for the simulation.</li> </ul>
2	<ul style="list-style-type: none"> <li>• [STRAIGHT]</li> <li>• [DIRECT]</li> <li>• [SOG]</li> </ul>	<ul style="list-style-type: none"> <li>• Sets a simulated course in a straight line.</li> <li>• Sets the heading for the simulation.</li> <li>• Sets the SOG (Speed Over Ground) for the simulation.</li> </ul>
3	<ul style="list-style-type: none"> <li>• [CIRCLE]</li> <li>• [DIRECT]</li> <li>• [RADIUS]</li> <li>• [ANGULAR SPD]</li> </ul>	<ul style="list-style-type: none"> <li>• Sets a simulated course in a circle.</li> <li>• Sets the direction of the circle. ([CW]: Clockwise; [CCW]:Counter-clockwise)</li> <li>• Sets the radius of the circle, in Nautical Miles.</li> <li>• Sets the speed at which to turn during the simulation.</li> </ul>

5. Referring to the figure and table above, select a parameter to set for the simulation, then press the **ENT** key. A settings pop up window appears.
6. Press the CursorPad to move the cursor and adjust the settings for the selected parameter. When the settings for the selected parameter are complete, select **ENTER**, at the bottom of the window, then press the **ENT** key. The [SIMULATION(MOVEMENT) SETTING] window appears.
7. When all parameter settings are complete, select **ENTER**, at the bottom of the [SIMULATION(MOVEMENT) SETTING] window, then press the **ENT** key. The [SIMULATION] menu appears.

- Select [ATTITUDE SETTING], then press the **ENT** key. The [SIMULATION(ATTITUDE) SETTING] window appears.

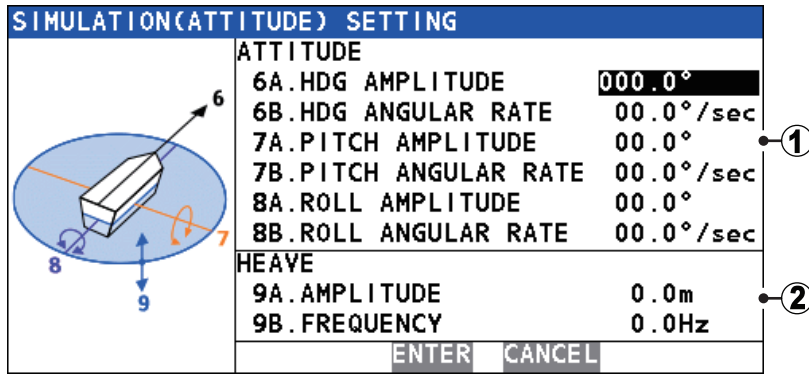

No.	Menu item	Description
1	[ATTITUDE] • [HDG AMPLITUDE] • [HDG ANGULAR RATE] • [PITCH AMPLITUDE] • [PITCH ANGULAR RATE] • [ROLL AMPLITUDE] • [ROLL ANGULAR RATE]	Attitude settings for heading, pitch and roll. • Sets the heading angle. • Sets the rate at which the heading changes. • Sets the pitch angle. • Sets the rate at which the pitch changes. • Sets the roll angle. • Sets the rate at which the roll changes.
2	[HEAVE] • [AMPLITUDE] • [FREQUENCY]	Settings for heave. • Sets the distance for heave. • Sets the frequency (Hz) for heave.

- Referring to the figure and table above, select a parameter to set for the simulation, then press the **ENT** key. A settings pop up window appears.
- Press the CursorPad to move the cursor and adjust the settings for the selected parameter. When the settings for the selected parameter are complete, select **ENTER**, at the bottom of the window, then press the **ENT** key. The [SIMULATION(ATTITUDE) SETTING] window appears.
- When all parameter settings are complete, select **ENTER**, at the bottom of the [SIMULATION(ATTITUDE) SETTING] window, then press the **ENT** key. The [SIMULATION] menu appears.
- Select [SIMULATION], then press the **ENT** key. The start/stop options window appears.
- Select [START]. A confirmation window appears. Select [YES] to start the simulation, or select [NO] to cancel.  
If you select [YES], the system restarts. When the restart is completed, the system operates in simulation mode and the simulation indicator is shown at the top-right of the display.

### How to stop the simulation

You can stop the simulation at any time from the menu.

- Referring to the steps 1 to 3 of the above procedure, open the [SIMULATION] menu.
- Select [SIMULATION], then press the **ENT** key. The start/stop options window appears.
- Select [STOP]. A confirmation window appears. Select [YES] to start the simulation, or select [NO] to cancel.  
If you select [YES], the system restarts. When the restart is completed, the system operates in normal mode and the simulation indicator is not shown at the top-right of the display.

### 2.17.2 SYSTEM SOUND menu

When a key is pressed the system releases a “key beep”. You can turn the key beeps on or off, to suit your preference.

1. Open the [MENU].
2. Select [SYSTEM], then press the **ENT** key.
3. Select [SYSTEM SOUND], then press the **ENT** key. The [SYSTEM SOUND] menu appears.



4. [KEY BEEP] is already selected, press the **ENT** key. The settings options window appears.  
**Note:** The [NOTIFICATION SOUND] menu item is reserved for technical personnel and is not selectable.
5. Select [ON] or [OFF] as appropriate, then press the **ENT** key.
6. Close the [MENU].

### 2.17.3 SYSTEM LOG menu

If a USB Flash Memory is connected to the Junction Box, you can save a system log file to the USB. To save a log file, do the following:

1. Open the [MENU].
2. Select [SYSTEM], then press the **ENT** key.
3. Select [SYSTEM LOG], then press the **ENT** key. The [SYSTEM LOG] menu appears.



4. [RECORDING] is already selected, press the **ENT** key. The settings options window appears.  
**Note:** The [LOG LEVEL] menu item is reserved for technical personnel and is not selectable.
5. Select [ON] or [OFF] as appropriate, then press the **ENT** key.
6. Close the [MENU].

### 2.17.4 How to save a sensor log

You can save a log file for your GNSS, sensor or offline (both GNSS and sensor) data.

1. Open the [MENU].
2. Select [SYSTEM], then press the **ENT** key.
3. Select [LOG RECORDING], then press the **ENT** key. The [LOG RECORDING] menu appears.
4. Select [LOG TYPE], then press the **ENT** key. An options pop up window appears.
5. Select the appropriate option, then press the **ENT** key.
  - [OFF]: No log data is saved.
  - [GNSS ONLY]: Only GNSS core log data is saved.
  - [SENSOR ONLY]: Only sensor log data is saved.
  - [OFFLINE DATA]: Both GNSS and sensor log data is saved as offline data.
6. Select [DESTINATION], then press the **ENT** key. An options pop up window appears.
7. Select the appropriate option, then press the **ENT** key.
  - [USB]: Log data is saved to the USB Flash Memory.
  - [MP]: Log data is saved to the device connected via the Remote Maintenance port.
8. Close the [MENU].



### 2.17.5 How to clear display settings and GPS memory

You can reset the display settings and clear the GNSS (GPS) memory.

1. Open the [MENU].
2. Select [SYSTEM], then press the **ENT** key.
3. Select [RESET SETTING], then press the **ENT** key. The [RESET SETTINGS] menu appears.
4. Select the appropriate option, then press the **ENT** key. A confirmation window appears.
 

**Note:** The [FACTORY DEFAULT] menu item is reserved for technical personnel and is not selectable.
5. Select [YES] to reset the settings, or [NO] to cancel.



## 2.18 ROTI Display Operations (RD-50/RD-20, option)

The optional RD-50/RD-20 Remote Display Unit is available as a remote display for ROTI data only. Operations and settings for the RD-50 are outlined in the RD-50 operator's manual (OME-44530-x; x denotes the manual version), supplied with the RD-50.



# 3. MAINTENANCE, TROUBLE-SHOOTING

## 3.1 Preventative Maintenance

Regular maintenance is necessary to maintain performance. A monthly maintenance program should be established and should at least include the items listed in the table below.

Item	Check point
Connectors	Check that all connectors on the rear panel of the Junction Box and display unit are firmly connected.
Cabling	Check cabling for damage. Replace if damaged.
Ground terminal	Check the ground terminal on the display unit and Junction Box for rust. Clean if necessary.
Ground wire	Check that the ground wire on the display unit and Junction Box is firmly fastened.
Display unit, Junction Box.	Dirt and dust should be removed from units with a soft, dry cloth. For the LCD, wipe it carefully to prevent scratching, using tissue paper and an LCD cleaner. To remove dirt or salt deposits, use an LCD cleaner, wiping slowly with tissue paper so as to dissolve the dirt or salt. Change paper frequently so the salt or dirt will not scratch the LCD. Do not use solvents such as thinner, acetone or benzene for cleaning any unit; they can remove paint and marks and deform the equipment.

## 3.2 Replacement of Fuse

### **WARNING**

**Use the proper fuse.**

Use of a wrong fuse can damage the equipment or cause fire.

The Junction Box (SC-701) contains fuses which protects the equipment from over-voltage, reverse polarity and equipment fault. If power cannot be turned on, check if the fuse has blown.

Only a qualified technician should change the fuse, contact your dealer and quote the fuse details listed below.

Used for	Fuse type	Code No.
SC-701	FBGO-A 125V 3A PBF	000-155-850-10
SC-702	FGMB 125V 0.3A PBF	000-176-821-10

### 3.3 Basic Troubleshooting

This section provides basic troubleshooting which the user may follow to restore normal operation. If the problem is not rectified, contact your dealer for advice.

Symptom	Possible cause and remedy
Cannot turn the power on.	Power cables may be damaged or corroded. Check the cables for corrosion or damage; replace as necessary.
	Power cable may be loose or disconnected. Check the cable connections are fastened firmly.
	Blown fuse. Check the fuses. If blown, contact your dealer for replacement.
	Ship battery may have low voltage. Check that the battery voltage is within rating.
Display screen is blank.	Brilliance level may be too low. Press the <b>BRILL</b> key to adjust the brilliance.
No position fix.	Antenna cable may be loose or disconnected. Check the antenna cable is fastened firmly.
	Unable to see more than two satellites. Check that there are no large obstructions preventing a clear view to the sky.
	GPS needs to be restarted. From the main menu, select [SYSTEM]→[RESET SETTINGS]→[CLEAR GNSS]→[YES].
Large error between actual and indicated location.	Positioning system may be incorrect or sensor is faulty. From the main menu, select [GNSS]. Confirm that the settings for [POSN. SYSTEM] and [MODE] are correct.
Heading indication changes randomly when the vessel is anchored or does not change when the vessel is moving.	Antenna may be poorly located or unable to obtain a positioning fix. 1) Check that the antenna has a clear view to the sky. 2) Check that the installation location is not subjected to excessive vibrations. 3) Check that there the antenna is not subject to interference from nearby equipment
	Sensor may be faulty. 1) Check the sensor status from the [SENSOR] menu. 2) Run a [DIAGNOSTIC TEST] from the [MAINTENANCE] menu. If one or more sensors are faulty, contact your dealer for advice.
Data output from the SC-70/SC-130 does not appear on external equipment.	Connection between the SC-70/SC-130 and external equipment is loose or damaged. Check connection, replace or reconnect/refasten as necessary.
	Output settings are incorrect. From the main menu, select [I/O], then select the output port. Confirm that the settings are correct.
	Sensor may be faulty. 1) Check the sensor status from the [SENSOR] menu. 2) Run a [DIAGNOSTIC TEST] from the [MAINTENANCE] menu. If one or more sensors are faulty, contact your dealer for advice.
	External equipment not set correctly. 1) Check the external equipment data input settings. 2) Output data and input data connection should set as follows: SC70/SC-130=TD-A ←connection→ external equipment=RD-A SC70/SC-130=TD-B ←connection→ external equipment=RD-B
The external equipment can not received CANbus (NMEA2000) data from SC-70/SC-130.	Turn on the CANbus network (NMEA2000) before the SC-70/SC-130. If the SC-70/SC-130 is turned on before the CANbus network (NMEA2000), reboot the SC-70/SC-130.

## 3.4 Maintenance Menu

The [MAINTENANCE] menu contains items such as diagnostic tests, unit information and other maintenance-specific menus. You can also save or load your user settings from this menu.

To access the [MAINTENANCE] menu, open the [MENU], then select [MAINTENANCE]. The [MAINTENANCE] menu appears.



### 3.4.1 How to find unit information

You can view your equipment's details from the [INFORMATION] menu. The displayed details include handy information such as program numbers and serial numbers.

1. From the [MAINTENANCE] menu, select [INFORMATION], then press the **ENT** key.
2. Select the unit whose information you want to view, then press the **ENT** key.
3. Select the part of the unit whose information you want to view, then press the **ENT** key.  
Items shown in gray are either not selectable, or have no information to view. Press **▲** or **▼** to scroll through the displayed information.

### 3.4.2 How to Backup User Settings

If a USB Flash Memory is connected at installation (see section 1.5.5), the SC-70/SC-130 can import or export user settings via external USB flash memory. This allows you to apply the same settings to multiple units, or recover settings if they are accidentally changed.

**Note:** The menu is inoperable while importing or exporting settings. Also, the import/export procedure cannot be stopped once it starts. For safety, conduct these operations while moored safely.

To import or export settings, do the following:

1. Open the [MENU].
2. Select [MAINTENANCE], then press the **ENT** key.
3. Select [IMPORT/EXPORT], then press the **ENT** key.
4. Select [IMPORT USER SETTINGS] or [EXPORT USER SETTINGS] as appropriate, then press the **ENT** key. A confirmation pop up window appears.
5. Select [YES] to import/export the user settings, [NO] to cancel the import/export. If [YES] is selected, a progress window appears, showing the overall progress of the import/export.  
If an error occurs during the import/export, an error message appears. Referring to the table on the following page, take the appropriate action.

### 3. MAINTENANCE, TROUBLESHOOTING

Error message	Meaning	Recommended action
"NO USB!"	No USB flash memory is connected to this unit.	Press the <b>MENU ESC</b> key to close the pop up. Check the connection. If a flash memory is connected, the USB connector/cable may be damaged, contact your dealer.
"ERROR DETECTED IN SETTINGS TRANSFER! RESTORING PREVIOUS SETTINGS."	Data transfer to/from the USB flash memory was interrupted/stopped. This unit will restore the settings used prior to import.	Press the <b>ACK</b> key to close the pop up and start restoring the settings.
"NOT ENOUGH SPACE ON USB."	USB flash memory does not have enough space to save the settings.	Delete unnecessary files from the USB or use a USB with sufficient memory.
"NO FILE FOUND ON USB."	There is no settings file saved on the connected USB.	Connect the correct USB.
"OTHER BACKUP PROCESS IS RUNNING."	Import/export was attempted while a separate backup (or log) is in progress.	Wait for the other backup/log to complete, then try again.

6. When the import/export is complete the progress window is replaced with a pop up window displaying the message "IMPORT COMPLETE" or "EXPORT COMPLETE".
7. Press the **ENT** key. The last used display screen appears.
8. Open the [MENU].
9. Select [SYSTEM], then press the **ENT** key.
10. Select [USB FLASH DRIVE], then press the **ENT** key.
11. Select [UNMOUNT], then press the **ENT** key.
12. Close the [MENU].

#### **How to remove the USB Flash Memory**

To remove the USB Flash Memory, open the MENU, then select [SYSTEM] → [USB FLASH DRIVE] → [UNMOUNT]. When the process is completed, the message "YOU CAN REMOVE THE USB SAFELY" appears. Remove the USB Flash Memory.

## 3.5 Diagnostic Tests

The [DIAGNOSTICS] menu has several diagnostic tests which may help find the cause of a problem. To access the [DIAGNOSTICS] menu, do the following:

1. Press the **MENU ESC** key to access the menu.
2. Select [MAINTENANCE], then press the **ENT** key.
3. Select [DIAGNOSTICS], then press the **ENT** key.

The following tests are available:

[MEMORY] TEST	: See section 3.5.1.
[KEY TEST]	: See section 3.5.2.
[LCD TEST]	: See section 3.5.3.
[AUTOMATIC TEST]	: See section 3.5.4.
[MANUAL TEST]	: For technical personnel only.
[SOUND TEST]	: See section 3.5.5.

4. Select the appropriate test, then press the **ENT** key.
5. Close the [MENU].

### 3.5.1 Memory test

The [MEMORY] test checks RAM, ROM, USB, LAN ports and data ports for the Junction Box (SC-701), the display unit (SC-702) and the antenna unit (SC-703/SC-1303).

Tested unit name appears here

SC-701	RAM	: OK	ETHERNET	: OK
	ROM	: OK	CANbus	: OK
	DATA 1	: OK	AD-10	: OK
	DATA 2	: OK	USB MEMORY	: OK
	DATA 3	: OK		
	DATA 4	: OK		
	DATA 5	: OK		
	INTERNAL LAN	: OK		
[BACK] [ENT] [RETRY TEST] [PREV] [NEXT]				

Press the ▲ or ▼ to cycle through the test result for each tested unit.

Press the **MENU ESC** key to close the results screen and return to the [SELF TEST] menu, or press the **ENT** key to repeat the test.

### 3.5.2 Keyboard test

The [KEYBOARD] test checks that the keys are functioning correctly.

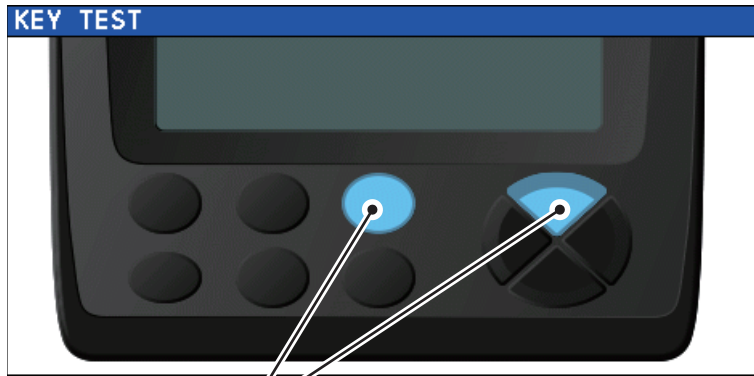

Keys are highlighted when the corresponding key is pressed. Press the key again and the highlight is removed.

If a key is malfunctioning, contact your dealer.

To close this test screen, press the **MENU ESC** key three times.

### 3.5.3 LCD test

The [TEST PATTERN] test checks the LCD display colors and patterns. This test changes the display color and shows patterns.

The test start screen shows operational guidance for the LCD test, as shown in the figure below.

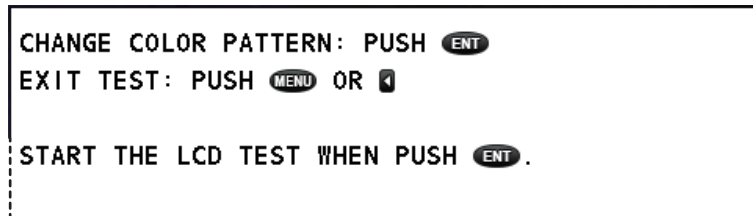

Press the **ENT** key to continue the test, or press the **MENU ESC** key to abort the test.

The colors and patterns appear in the order shown below.

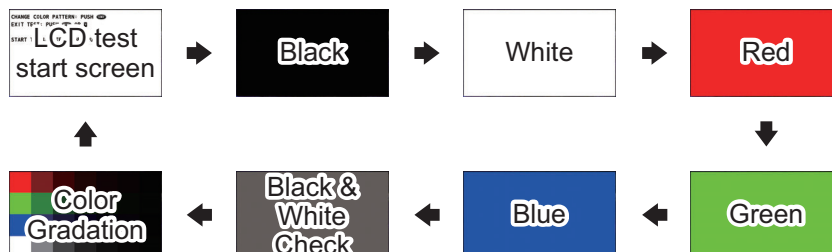

If the colors are not displayed correctly, or show signs of LCD damage, contact your dealer.

### 3.5.4 Automatic Test

The [AUTOMATIC TEST] conducts a brief test on the LCD, keyboard (SC-702) and memory (SC-701, SC-702 and SC-703).

This saves you the time it takes to conduct each test individually. If an error is detected during any of the automatic tests, the test stops. Check the item in question and consult your dealer if necessary.

The [AUTOMATIC TEST] does the following in numerical order:

- 1) Displays the PC board version numbers and program version numbers for the display unit, junction box and the connected antenna. Results are displayed for approximately five seconds, then step 2 is initiated.
- 2) Tests RAM/ROM and data input/output. (See section 3.5.1.) Results are displayed for approximately five seconds, then step 3 is initiated.
- 3) Tests the SC-702 keys. (See section 3.5.2.) Proceeds to step 4 if no key is pressed within five seconds.
- 4) Tests the LCD. (See section 3.5.3.) Displayed test screens changes after two seconds until the “checkered flag” screen appears. Proceeds to step 5 if no key is pressed within five seconds.
- 5) Tests screen brilliance. Press the **BRILL** key to cycle through the brilliance settings in the following order:

Maximum brilliance → Medium brilliance → Minimum brilliance  
 ↑-----|

Repeats the tests from step 1 if no key is pressed within five seconds.  
 To exit this test, press the **MENU ESC** key.

**Note:** The SC-70/SC-130 continues data output while this test is active.

### 3.5.5 Sound test

Use the sound test to check the buzzer. Press ▲ or ▼ to change the buzzer’s sound frequency.

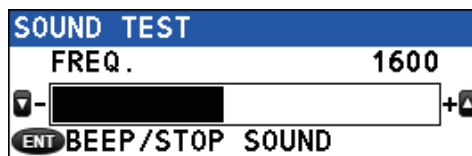

The frequency range is 1400 (Hz) to 1850 (Hz).

**Note:** The settings used for the sound test are not saved.

### 3. MAINTENANCE, TROUBLESHOOTING

This page is intentionally left blank.



# APPENDIX 1 MENU TREE

---

## Main menu

- | 1 DISPLAY ***Bold Italic*** : Default
- | 2 GNSS
- | 3 ALERT
- | 4 MAINTENANCE
- | 5 I/O
- | 6 SENSOR **\***: Requires password access. For technical personnel only.
- | 7 SYSTEM
- | 8 SERVICE\*

## 1 DISPLAY

- | 1 BKGD COLOR (***WHITE***, BLACK)
- | 2 UNIT
  - | 1 DISTANCE (***NM***, KM, SM)
- | 3 SMOOTHING
  - | 1 VTG (***0000s*** to 9999s)
  - | 2 6DoF (***0000s*** to 9999s)
  - | 3 OS SPEED(X,Y)\***6** (***0000s*** to 9999s) **\*6: Non-IMO only, fixed for IMO**
  - | 4 ROT (00s to 30s, default: ***04s***)
- | 4 DECIMAL ROUNDING
  - | 1 VTG (***1***, 2, 3)
  - | 2 VBW\***6** (***1***, 2, 3)
  - | 3 HDG (***1***, 2, 3)
  - | 4 ROLL, PITCH (***1***, 2, 3)
- | 5 DATUM (***WGS84***, WGS72, PZ90, CK42, CK95, OTHERS)
- | 6 TRIP SETTING\***6**
  - | 1 CLEAR
- | 7 TIME
  - | 1 LOCAL TIME (***UTC***, LOCAL)
  - | 2 SUMMER TIME (ON, ***OFF***)
- | 8 LANGUAGE
  - | 1 ***ENGLISH***
  - | 2 日本語 (Japanese)

## 2 GNSS

- | 1 POSN. SYSTEM
  - | 1 GPS
- | 2 MODE (***AUTO(2D/3D)***, 2D) (For technical personnel only. Do not use.)
- | 3 POSN. CONDITION
  - | 1 QZSS (***ON***, OFF)
  - | 2 ELEVATION MASK (***5°*** to 90°) (For technical personnel only. Do not use.)
  - | 3 IGNORED GNSS
    - | 1 QZSS
    - | 2 GPS
    - | 3 GLONASS
    - | 4 GALILEO
- | 4 DGPS/SBAS
  - | 1 DIFFERENTIAL (GNSS, GNSS+SBAS, GNSS+EXTERNAL, ***AUTO***)
  - | 2 SBAS SEARCH (***AUTO***, MANUAL)
  - | 3 IGNORED SBAS
  - | 4 BEACON SETUP (***AUTO***, MANUAL)
- | 5 RAIM
  - | 1 RAIM FOR GPS
    - | 1 SETTING (***ON***, OFF)
    - | 2 ACCURACY LEVEL (001m to 999m, default: ***100m***)
- | 6 ROLL OVER (2000 to 2099, default: ***2016***)
- | 7 SETUP\***1** **\*1: Requires password access. For service personnel only.**

Continued on page AP-2

APPENDIX 1 MENU TREE

Continued from page AP-1

3 ALERT

- | 1 ALERT LIST
- | 2 REMOTE ACK I/F (**ACK**, BUZZER STOP)\*7
- | 3 SOUND (OFF, SHORT, **LONG**, CONTINUOUS)\*5     \*5: Non-IMO types only.
- | 4 ALERT LOG     Fixed for IMO types.

4 MAINTENANCE

- | 1 INFORMATION     \*7: Available on when Alert Mode is set to Legacy.
  - | 1 DISPLAY UNIT
    - | 1 MAIN PCB
    - | 2 LCD
  - | 2 ANTENNA UNIT
    - | 1 MAIN PCB
    - | 2 SUB IMU (Not available where there is no SUB\_IMU board)
    - | 3 LAN\_CNV PCB
    - | 4 GNSS\_LNA 1
    - | 5 GNSS\_LNA 2
    - | 6 GNSS\_LNA 3 (Available only for SC-130 systems)
  - | 3 JUNCTION BOX
    - | 1 MAIN PCB
    - | 2 LAN\_CNV PCB
    - | 3 TB\_PWR PCB
- | 2 DIAGNOSTICS
  - | 1 MEMORY TEST
  - | 2 KEY TEST
  - | 3 LCD TEST
  - | 4 AUTOMATIC TEST
  - | 5 MANUAL TEST (For technical personnel only. Do not use.)
  - | 6 SOUND TEST
- | 3 IMPORT/EXPORT
  - | IMPORT USER SETTING
  - | EXPORT USER SETTING

5 I/O

- | 1 DATA 1
  - | 1 DATA OUTPUT (**IEC/NMEA**, RTCM\*2)     \*2: Selectable for DATA5 only
  - | 2 OUTPUT FORMAT (**IEC61162-1 ED.4**, IEC61162-1 ED.3, NMEA0183 V2.0, NMEA0183 V1.5)
  - | 3 TALKER\*3 (GP, GL, GA, GN, **HE**, HN, HC) \*3: Non-IMO only, fixed for IMO
  - | 4 BAUD RATE (4800bps, 9600bps, 19200bps, **38400bps**) \*3 \*4
  - | 5 SENTENCES     \*4: Default for IEC61162-2 is 38400bps
- | 2 DATA 2
  - | 1 DATA OUTPUT (**IEC/NMEA**, RTCM\*2)
  - | 2 OUTPUT FORMAT (**IEC61162-1 ED.4**, IEC61162-1 ED.3, NMEA0183 V2.0, NMEA0183 V1.5)
  - | 3 TALKER (GP, GL, GA, GN, **HE**, HN, HC)
  - | 4 BAUD RATE (**4800bps**, 9600bps, 19200bps, 38400bps)
  - | 5 SENTENCES
- | 3 DATA 3 (Same as DATA 2)
- | 4 DATA 4 (Same as DATA 2)
- | 5 DATA 5 (Same as DATA 2)
- | 6 NETWORK
  - | 1 TALKER\*6 (GP, GL, GA, GN, **HE**, HN, HC)     \*6: Non-IMO only, fixed for IMO
  - | 2 SENTENCES
  - | 3 IP ADDRESS/PORT
- | 7 DATA SOURCE
  - | 1 HDG (**INTERNAL LAN**, DATA 1, DATA 2, DATA 3, DATA 4, DATA 5, USER PRIORITY)
  - | 2 EXT. STW\*6 (DATA 1, DATA 2, DATA 3, DATA 4, DATA 5, **USER PRIORITY**)
- | 8 I/O LOGS
  - | 1 DATA 1(Shows TX/RX log)
  - | 2 DATA 2(Shows TX/RX log)
  - | 3 DATA 3(Shows TX/RX log)
  - | 4 DATA 4(Shows TX/RX log)
  - | 5 DATA 5(Shows TX/RX log)
  - | 6 ETHERNET
  - | 7 CANbus
  - | 8 LAN ERROR LOG
- | 9 MISCELLANEOUS
  - | 1 HDG OUTPUT RESTART (**AUTO**, MANUAL)
  - | 2 STW\*6 (**VECTOR**, SCALAR)

Continued on page AP-3

Continued from page AP-2

## 6 SENSOR

- | 1 OFFSET (For technical personnel only. Do not use.)
  - | 1 HDG OFFSET (-180°000' to +180°000', default: **+0.000°**)
  - | 2 PITCH OFFSET (-10°000' to +10°000', default: **+0.000°**)
  - | 3 ROLL OFFSET (-10°000' to +10°000', default: **+0.000°**)
  - | 4 POSITION OFFSET
  - | 5 DIMENSIONS/CCRP
  - | 6 SOG OFFSET -12.5% to +12.5%, default: **+00.0%** )
  - | 7 ATM OFFSET (-99.9hPa to +99.9hPa, default: **00.0hPa**)
  - | 8 TEMP OFFSET (-99.9°C to +99.9°C, default: **+00.0°C**)
- | 2 OTHER
  - | 1 ANTENNA RESTART (For technical personnel only. Do not use.)
  - | 2 GNSS RESTART
  - | 3 CLEAR MAGNETIC DEVICE(For technical personnel only. Do not use.)
  - | 4 DR TIME (1min, 2min, 3min, 4min, **5min**)
  - | 5 MAGNETIC VARIATION\*6 (**AUTO** , MANUAL)
- | 3 SENSOR STATUS \*6: Non-IMO only, fixed for IMO

## 7 SYSTEM

- | 1 NETWORK (For technical personnel only. Do not use.)
  - | 1 ETHERNET
  - | 2 EQUIPMENT ID (001 to 999, default: **1**)
  - | 3 MP PORT (**ENABLE** , DISABLE)
  - | 4 MP IP ADDRESS/PORT
  - | 5 SFI
- | 2 SIMULATION
  - | 1 MOVEMENT SETTING
  - | 2 ATTITUDE SETTING
  - | 3 SIMULATED OUTPUT (**FULL SIMULATION** , FIX, DIFFERENTIAL FIX, ESTIMATION (DR), MANUAL INPUT, NO FIX) (For technical personnel only. Do not use.)
  - | 4 SIMULATION START (START, **STOP**)
- | 3 SYSTEM SOUND
  - | 1 KEY BEEP (**ON** , OFF)
  - | 2 NOTIFICATION SOUND (OFF, **ON** , CONTINUOUS) (For technical personnel only. Do not use.)
- | 4 SYSTEM LOG
  - | RECORDING (ON, **OFF**)
  - | LOG LEVEL (For technical personnel only. Do not use.)
- | 5 LOG RECORDING
  - | 1 LOG TYPE (**OFF** , GNSS ONLY, SENSOR ONLY, OFFLINE DATA)
  - | 2 DESTINATION (**USB** , MP)
- | 6 RESET SETTINGS
  - | 1 CLEAR DISPLAY SETTINGS
  - | 2 CLEAR GNSS
  - | 3 FACTORY DEFAULT (For service personnel only. Do not use.)
- | 7 PASSWORD
  - | 1 LOGOUT \*7: Shown only if a USB device is connected.
  - | 2 CHANGE
- | 8 USB FLASH DRIVE (**UNMOUNT**) \*7

8 SERVICE — EDIT (**LOCK** , UNLOCK) (Password protected. For technical personnel only.)

# APPENDIX 2 ALERT LIST

The table below shows the alert no., alert name, text, priority, meaning and remedy for each alert. The alerts table is grouped by device mode. Alerts are not shared between device modes.

**Note 1:** "Inst." in the following tables denotes "Instance number" for the alert.

**Note 2:** "GNSS CORE(4) FAULT" appears only if SC-1303 is connected to the system.

No.	Inst.	Alert name	Text	Priority/Category	Meaning
<b>GPS mode alerts</b>					
210	1	HDOP EXCEEDED	HDOP EXCEEDED	Caution/B	The value of HDOP (Horizontal Dilution of Precision) is 4 or above. HDOP threshold being permanently set to 4.
Remedy: If the same state continues for five minutes, contact your dealer.					
212	1	LOSS OF POSITION	GNSS CORE(1) FAULT	Warning/B	GNSS module may be faulty.
	5		TOO FEW TRACKING SATELLITES		Not enough satellites available to fix position.
	6		ANTENNA UNIT CONNECTION LOST		Data connection to the antenna has been interrupted or the physical connection is disconnected.
Remedy: If the same state continues for five minutes, contact your dealer.					
<b>THD mode alerts</b>					
440301	1	DEAD RECKONING	DEAD-RECKONING	Caution/B	The heading is calculated using ROT, not GPS position.
Remedy: If this alert occurs frequently, contact your dealer.					
440302	2	OUTPUT STOPPED (HDG)	GNSS CORE(2) FAULT	Warning/B	GNSS module may be faulty.
	3		GNSS CORE(3) FAULT		GNSS module may be faulty.
	4		GNSS CORE(4) FAULT		GNSS module may be faulty. <b>Note:</b> Shown only for system configuration with SC-1303 included.
	5		TOO FEW TRACKING SATELLITES		Not enough satellites available to fix position.
	6		ANTENNA UNIT CONNECTION LOST		Data connection to the antenna has been interrupted or the physical connection is disconnected.
	7		RATE GYRO BROKEN DOWN		Rate gyro may be faulty.
	8		ACCELEROMETER BROKEN DOWN		Accelerometer may be faulty
Remedy: If the same state continues for five minutes, contact your dealer.					

No.	Inst.	Alert name	Text	Priority/ Category	Meaning
<b>ROTI mode alerts</b>					
440303	2	OUTPUT STOPPED (ROT)	GNSS CORE(2) FAULT	Warning/ B	GNSS module may be faulty.
	3		GNSS CORE(3) FAULT		GNSS module may be faulty.
	4		GNSS CORE(4) FAULT		GNSS module may be faulty. <b>Note:</b> Shown only for system configuration with SC-1303 included.
	5		TOO FEW TRACKING SATELLITES		Not enough satellites available to fix position.
	6		ANTENNA UNIT CONNECTION LOST		Data connection to the antenna has been inter- rupted or the physical connection is discon- nected.
	7		RATE GYRO BROKEN DOWN		Rate gyro may be faulty.
	8		ACCELEROM- ETERBROKEN DOWN		Accelerometer may be faulty
	Remedy: If the same state continues for five minutes, contact your dealer.				
<b>SPD mode alerts</b>					
440311	2	OUTPUT STOPPED (SPD)	GNSS CORE(2) FAULT	Warning/ B	GNSS module may be faulty.
	3		GNSS CORE(3) FAULT		GNSS module may be faulty.
	4		GNSS CORE(4) FAULT		GNSS module may be faulty.
	5		TOO FEW TRACKING SATELLITES		Not enough satellites available to fix position.
	6		ANTENNA UNIT CONNECTION LOST		Data connection to the antenna has been inter- rupted or the physical connection is discon- nected.
	7		RATE GYRO BROKEN DOWN		Rate gyro may be faulty.
	8		ACCELEROM- ETERBROKEN DOWN		Accelerometer may be faulty
	Remedy: If the same state continues for five minutes, contact your dealer.				

# APPENDIX 3 ABBREVIATIONS AND UNITS





Term	Meaning	Term	Meaning
<b>Numerical:</b>			
2D	Two Dimensional Positioning	3D	Three Dimensional Positioning
<b>A:</b>			
ACK	Acknowledge	APR	April
ADR	Address	ARPA	Automatic Radar Plotting Aid
AIS	Automatic Identification System	ATM	Atmospheric Pressure
ALARM	Alarm	AUG	August
ANT	Antenna	Auto	Automatic
<b>B:</b>			
BAM(S)	Bridge Alert Management (System)	BRG	Bearing
BKGD	Background	BRILL	Brilliance
BL	BaseLine	bps	Bits Per Second
<b>C:</b>			
CAN	Controlled Area Network	CNV	Converter
CALC	GPS baseline calculation	COM.	Common
CCRP	Consistent Common Reference Point	COG	Course Over Ground
CLR	Clear	CPU	Central Processing Unit
<b>D:</b>			
DEC	December	DR	Dead Reckoning
deg	Degree(s)	DST	Destination
deg/min	Degree(s) per minute	D2D	Differential + 2D
DISP	Display	D3D	Differential + 3D
DGPS	Differenetal GPS		
<b>E:</b>			
E	East	ENT	Enter
ECDIS	Electronic Chart Display and Information System	EXT.	External
EGNOS	European Geostationary Navigational Overlay System		
<b>F:</b>			
FEB	February	FREQ	Frequency
FIX	Fix		
<b>G:</b>			
GLONASS	Global Opening Navigation Satellite System	GNSS	Global Navigation Satellite System
GND	Ground	GPS	Global Positioning System
GP-3D	GPS used for position fix.	GP-D3D	GPS differential used for position fix.
<b>H:</b>			
HDG	Heading	hPa	Hectopascal
HDOP	Horizontal Dilution of Position		
<b>I:</b>			
ID	Identification	INFO	Information
I/F	Interface	INIT	Initial
IEC	International Electrotechnical Commission	I/O	Input/Output
IMO	International Maritime Organization	IP	Internet Protocol
IMU	Inertial Measurement Unit		
<b>J:</b>			
JAN	January	JUN	June
JUL	July		
<b>L:</b>			
L	Local (time)	L/L	Latitude/Longitude
LAN	Local Area Network	LOC	Location
LEN	Load Equivalency Number	LOG	Log
LCD	Liquid Crystal Display		

APPENDIX 3 ABBREVIATIONS AND UNITS

<b>M:</b>			
MAR	March	MP	Management Profile
MAY	May	MSAS	Multi-Functional Satellite Augmentation System
MENU	Menu		
<b>N:</b>			
N	North	NMEA	National Marine Electronics Association
N/A	Not Available	NOV	November
NG	Not Good	NO.	Number
<b>O:</b>			
OCT	October	ON	On
OFFSET	Offset	OS	Own Ship
<b>P:</b>			
PC	Printed Circuit	PGN	Parameter Group Number
PCB	Printed Circuit Board	PORT	Port
PDOP	Positional Dilution Of Precision	PRN	Pseudo-Random Noise
POSN	Position		
<b>Q:</b>			
QZSS	Quasi-Zenith Satellite System		
<b>R:</b>			
RAM	Random Access Memory	ROM	Read Only Memory
RAIM	Receiver Autonomous Integrity Monitoring	ROT	Rate Of Turn
RECT	Rectified	ROTI	Rate Of Turn Indicator
RMS	Root Mean Square	RTCM	Radio Technical Commission for Marine Service
RNG	Range	RX	Receive
<b>S:</b>			
S	South	SOG	Speed Over Ground
SAT	Satellite	SPD	Speed
SBAS	Satellite Base Argument System	SRC	Source
SC	Satellite Compass	SS	Signal Sensitivity
SEP	September	STBD	Starboard
SET	Set (i.e. set and drift, or setting a value)	STW	Speed Through the Water
SFI	System Function ID	SV	Space Vehicle
SIM	Simulation	SYS	System
SN	Signal to Noise	S2D	SBAS + 2D
SNR	Signal to Noise Ratio	S3D	SBAS + 3D
<b>T:</b>			
T	TRUE	THD	Transmitting Heading Device
TEST	Test	TIME	Time
TEMP	Temperature	TX	Transmit
<b>U:</b>			
U/UTC	Universal Time, Coordinated	USB	Universal Serial Bus
<b>W:</b>			
W	West	WGS	World Geodetic System
WAAS	Wide Area Augmentation System	WGS84	World Geodetic System 84
<b>Units of measurement</b>			
Unit	Meaning	Unit	Meaning
°	Degree(s)	m/s	Meter(s) per second
°/min	Degree(s) per minute	ms	Milisecond(s)
dB	Decibel(s)	NM	Nautical Mile(s)
kHz	Kilohertz	Ω	Ohm(s)
KM	Kilometer(s)	s	Second(s)
m	Meter(s)	SM	Statue Mile(s)
min or '	Minute(s)		







# APPENDIX 4 ICONS AND SYMBOLS

## Standard icons and their meanings

Icon	Meaning	Icon	Meaning
 See note below.	Excessive vibrations detected at the antenna installation location. Check the antenna installation location and change if necessary.	 Shown in light blue for IMO types, dark-blue for non-IMO types.	Blue indication rotates in a clock-wise direction, indicating that the equipment is functioning correctly. If this indication is not moving, the system may be frozen. Restart the system. If the problem recurs, contact your dealer.
 See note below.	Indicates that five or more satellites are under use for calculating velocity and own ship's movement.		Simulation icon. The system is currently operating in simulation mode.

**Note:** Icon background color changes according to the SC-702 background color.

## Alert icons and their meanings

Icons	Meaning	Icons	Meaning
	Active, unacknowledged warning		Active, responsibility transferred warning
	Silenced warning		Active, acknowledged warning
	Rectified, unacknowledged warning		Caution



# APPENDIX 5 GEODETIC CHART CODES

001: WGS84		
002: WGS72		
003: TOKYO	: Mean Value (Japan, Korea & Okinawa)	
004: NORTH AMERICAN 1927	: Mean Value (CONUS)	
005: EUROPEAN 1950	: Mean Value	
006: AUSTRALIAN GEODETIC 1984	: Australia & Tasmania	
007: ADINDAN	: Mean Value (Ethiopia & Sudan)	
008: ADINDAN	: Ethiopia	
009: ADINDAN	: Mali	
010: ADINDAN	: Senegal	
011: ADINDAN	: Sudan	
012: AFG	: Somalia	
013: AIN EL ABD 1970	: Bahrain Is.	
014: ANNA 1 ASTRO 1965	: Cocos Is.	
015: ARC 1950	: Mean Value	
016: ARC 1950	: Botswana	
017: ARC 1950	: Lesotho	
018: ARC 1950	: Malawi	
019: ARC 1950	: Swaziland	
020: ARC 1950	: Zaire	
021: ARC 1950	: Zambia	
022: ARC 1950	: Zimbabwe	
023: ARC 1960	: Mean Value (Kenya & Tanzania)	
024: ARC 1960	: Kenya	
025: ARC 1960	: Tanzania	
026: ASCENSION IS. 1958	: Ascension Is.	
027: ASTRO BEACON "E"	: Iwo Jima Is.	
028: ASTRO B4 SOR. ATOLL	: Tern Is.	
029: ASTRO POS 71/4	: St. Helena Is.	
030: ASTRONOMIC STATION 1952	: Marcus Is.	
031: AUSTRALIAN GEODETIC 1966	: Australia & Tasmania	
032: BELLEVUE (IGN)	: Efate & Erromango Is.	
033: BERMUDA 1957	: Bermuda Is.	
034: BOGOTA OBSERVATORY	: Columbia	
035: CAMPO INCHAUSPE	: Argentina	
036: CANTON IS. 1966	: Phoenix Is.	
037: CAPE	: South Africa	
038: CAPE CANAVERAL	: Mean Value (Florida & Bahama Is.)	
039: CARTHAGE	: Tunisia	
040: CHATHAM 1971	: Chatham Is. (New Zealand)	
041: CHUAA ASTRO	: Paraguay	
042: CORREGO ALEGRE	: Brazil	
043: DJAKARTA (BATAVIA)	: Sumatra Is. (Indonesia)	
044: DOS 1968	: Gizo Is. (New Georgia Is.)	
045: EASTER IS. 1967	: Easter Is.	
046: EUROPEAN 1950 (Cont'd)	: Western Europe	
047: EUROPEAN 1950 (Cont'd)	: Cyprus	
048: EUROPEAN 1950 (Cont'd)	: Egypt	
049: EUROPEAN 1950 (Cont'd)	: England, Scotland, Channel & Shetland Is.	
050: EUROPEAN 1950 (Cont'd)	: England, Ireland, Scotland & Shetland Is.	
051: EUROPEAN 1950 (Cont'd)	: Greece	
052: EUROPEAN 1950 (Cont'd)	: Iran	
053: EUROPEAN 1950 (Cont'd)	: Italy, Sardinia	
054: EUROPEAN 1950 (Cont'd)	: Italy, Sicily	
055: EUROPEAN 1950 (Cont'd)	: Norway & Finland	
056: EUROPEAN 1950 (Cont'd)	: Portugal & Spain	
057: EUROPEAN 1979	: Mean Value	
058: GANDAJIKA BASE	: Republic of Maldives	
059: GEODETIC DATUM 1949	: New Zealand	
060: GUAM 1963	: Guam Is.	
061: GUX 1 ASTRO	: Guadalcanal Is.	
062: HJORSEY 1955	: Iceland	
063: HONG KONG 1963	: Hong Kong	
064: INDIAN	: Thailand & Vietnam	
065: INDIAN	: Bangladesh, India & Nepal	
066: IRELAND 1965	: Ireland	
067: ISTS 073 ASTRO 1969	: Diego Garcia	
068: JOHNSTON IS. 1961	: Johnston Is.	
069: KANDAWALA	: Sri Lanka	
070: KERGUELEN IS.	: Kerguelen Is.	
071: KERTAU 1948	: West Malaysia & Singapore	
072: LA REUNION	: Mascarene Is.	
073: L. C. 5 ASTRO	: Cayman Brac Is.	
074: LIBERIA 1964	: Liberia	
075: LUZON	: Philippines (excl. Mindanao Is.)	
076: LUZON	: Mindanao Is.	
077: MAHE 1971	: Mahe Is.	
078: MARCO ASTRO	: Salvage Islands	
079: MASSAWA	: Eritrea (Ethiopia)	
080: MERCHICH	: Morocco	
081: MIDWAY ASTRO 1961	: Midway Is.	
082: MINNA	: Nigeria	
083: NAHRWAN	: Masirah Is. (Oman)	
084: NAHRWAN	: United Arab Emirates	
085: NAHRWAN	: Saudi Arabia	
086: NAMIBIA	: Namibia	
087: MAPARIMA, BWI	: Trinidad & Tobago	
088: NORTH AMERICAN 1927	: Western United States	
089: NORTH AMERICAN 1927	: Eastern United States	
090: NORTH AMERICAN 1927	: Alaska	
091: NORTH AMERICAN 1927	: Bahamas (excl. San Salvador Is.)	
092: NORTH AMERICAN 1927	: Bahamas, San Salvador Is.	
093: NORTH AMERICAN 1927 (Cont'd)	: Canada (incl. Newfoundland Is.)	
094: NORTH AMERICAN 1927 (Cont'd)	: Alberta & British Columbia	
095: NORTH AMERICAN 1927 (Cont'd)	: East Canada	
096: NORTH AMERICAN 1927 (Cont'd)	: Manitoba & Ontario	
097: NORTH AMERICAN 1927 (Cont'd)	: Northwest Territories & Saskatchewan	
098: NORTH AMERICAN 1927 (Cont'd)	: Yukon	
099: NORTH AMERICAN 1927 (Cont'd)	: Canal Zone	
100: NORTH AMERICAN 1927 (Cont'd)	: Caribbean	
101: NORTH AMERICAN 1927 (Cont'd)	: Central America	
102: NORTH AMERICAN 1927 (Cont'd)	: Cuba	
103: NORTH AMERICAN 1927 (Cont'd)	: Greenland	
104: NORTH AMERICAN 1927 (Cont'd)	: Mexico	
105: NORTH AMERICAN 1983	: Alaska	
106: NORTH AMERICAN 1983	: Canada	
107: NORTH AMERICAN 1983	: CONUS	
108: NORTH AMERICAN 1983	: Mexico, Central America	
109: OBSERVATORIO 1966	: Corvo & Flores Is. (Azores)	
110: OLD EGYPTIAN 1930	: Egypt	
111: OLD HAWAIIAN	: Mean Value	
112: OLD HAWAIIAN	: Hawaii	
113: OLD HAWAIIAN	: Kauai	
114: OLD HAWAIIAN	: Maui	
115: OLD HAWAIIAN	: Oahu	
116: OMAN	: Oman	
117: ORDNANCE SURVEY OF GREAT BRITAIN 1936	: Mean Value	
118: ORDNANCE SURVEY OF GREAT BRITAIN 1936	: England	
119: ORDNANCE SURVEY OF GREAT BRITAIN 1936	: England, Isle of Man & Wales	
120: ORDNANCE SURVEY OF GREAT BRITAIN 1936	: Scotland & Shetland Is.	
121: ORDNANCE SURVEY OF GREAT BRITAIN 1936	: Wales	
122: PICO DE LAS NIVIES	: Canary Is.	
123: PITCAIRN ASTRO 1967	: Pitcairn Is.	
124: PROVISIONAL SOUTH CHILEAN 1963	: South Chile (near 53°S)	
125: PROVISIONAL SOUTH AMERICAN 1956	: Mean Value	
126: PROVISIONAL SOUTH AMERICAN 1956	: Bolivia	
127: PROVISIONAL SOUTH AMERICAN 1956	: Chile-Northern Chile (near 19°S)	
128: PROVISIONAL SOUTH AMERICAN 1956	: Chile-Southern Chile (near 43°S)	
129: PROVISIONAL SOUTH AMERICAN 1956	: Columbia	
130: PROVISIONAL SOUTH AMERICAN 1956	: Ecuador	
131: PROVISIONAL SOUTH AMERICAN 1956	: Guyana	
132: PROVISIONAL SOUTH AMERICAN 1956	: Peru	
133: PROVISIONAL SOUTH AMERICAN 1956	: Venezuela	
134: PUERTO RICO	: Puerto Rico & Virgin Is.	
135: QATAR NATIONAL	: Qatar	
136: QORNOQ	: South Greenland	
137: ROME 1940	: Sardinia Is.	
138: SANTA BRAZ	: Sao Miguel, Santa Maria Is. (Azores)	
139: SANTO (DOS)	: Espirito Santo Is.	
140: SAPPER HILL 1943	: East Falkland Is.	
141: SOUTH AMERICAN 1969	: Mean Value	
142: SOUTH AMERICAN 1969	: Argentina	
143: SOUTH AMERICAN 1969	: Bolivia	
144: SOUTH AMERICAN 1969	: Brazil	
145: SOUTH AMERICAN 1969	: Chile	
146: SOUTH AMERICAN 1969	: Columbia	
147: SOUTH AMERICAN 1969	: Ecuador	
148: SOUTH AMERICAN 1969	: Guyana	
149: SOUTH AMERICAN 1969	: Paraguay	
150: SOUTH AMERICAN 1969	: Peru	
151: SOUTH AMERICAN 1969	: Trinidad & Tobago	
152: SOUTH AMERICAN 1969	: Venezuela	
153: SOUTH ASIA	: Singapore	
154: SOUTHEAST BASE	: Porto Santo & Madeira Is.	
155: SOUTHWEST BASE	: Faial, Graciosa, Pico, Sao Jorge & Terceira Is.	
156: TIMBALAI 1948	: Brunei & East Malaysia (Sarawak & Sabah)	
157: TOKYO	: Japan	
158: TOKYO	: Korea	
159: TOKYO	: Okinawa	
160: TRISTAN ASTRO 1968	: Tristan da Cunha	
161: VITI LEVU 1916	: Viti Levu Is. (Fiji Is.)	
162: WAKE-ENIWETOK 1960	: Marshall Is.	
163: ZANDERIJ	: Surinam	
164: BUKIT RIMPAH	: Bangka & Belitung Is. (Indonesia)	
165: CAMP AREA ASTRO	: Camp Marmuro Area, Antarctica	
166: G. SEGARA	: Kalimantan Is. (Indonesia)	
167: HERAT NORTH	: Afghanistan	
168: HU-TZU-SHAN	: Taiwan	
169: TANANARIVE OBSERVATORY 1925	: Madagascar	
170: YACARE	: Uruguay	
171: RT-90	: Sweden	
172: CK42 (PULKOVO 1942)	: Russia	
173: FINNISH KKKJ	: Finland	
174: PZ90	: Russia	
175: CK95	: Russia	

# APPENDIX 6 WHAT IS SBAS?

A satellite based augmentation system, or SBAS (Satellite Based Augmentation System), is an augmentation system that uses additional messages from satellite broadcasts to support regional and wide area augmentation. SBAS provides GPS signal corrections to SBAS users, for even better position accuracy, through the GPS error corrections that are widely broadcast from the geostationary satellite.

SBAS is used in America, Europe, Japan and India.

- America: WAAS (Wide Area Augmentation System)
- Europe: EGNOS (Euro Geostationary Navigation Overlay Service)
- Japan: MSAS (Multi-Functional Satellite Augmentation System)
- India: GAGAN (GPS And GEO Augmented Navigation)

These four systems have interoperability. The illustration below shows the coverage area for each provider. This manual uses "SBAS" for these four providers generically.

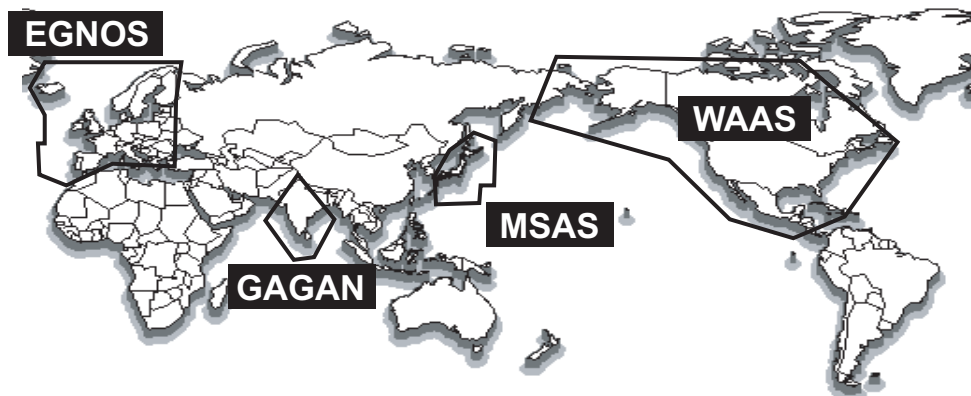

Provider	Satellite type	Longitude	Satellite No.
WAAS	Intelsat Galaxy XV	133°W	135
	TeleSat Anik F1R	107.3°W	138
	Inmarsat-4-F3	98°W	133
EGNOS	Inmarsat-3-F2/AOR-E	15.5°W	120
	Inmarsat-4-F2	25°E	126
	SES-5	5°E	136
MSAS	MTSAT-1R	140°E	129
	MTSAT-2	145°E	137
GAGAN	GSAT-8	55°E	127
	GSAT-10	83°E	128

As of March 6th, 2014

# APPENDIX 7 DIGITAL INTERFACE (IEC 61162-1 EDITION 4(2010-11))

## Serial data sentences

**Input:** ACK, ACN (ACM), HBT, HDT\*<sup>1</sup>, MSK, MSS, THS, VBW\*<sup>2</sup>, VDR\*<sup>2</sup>

**Output:** ALC, ALF, ALR, ARC, DTM, GBS, GGA, GLL, GNS, GRS, GSA, GST, GSV, HBT, HDG\*<sup>2</sup>, HDM\*<sup>2</sup>, HDT\*<sup>1</sup>, HRM\*<sup>2</sup>, MSK, POS, RMC, ROT, THS, VBW\*<sup>2</sup>, VDR\*<sup>2</sup>, VHW\*<sup>2</sup>, VLW\*<sup>2</sup>, VTG, XDR\*<sup>2</sup>, ZDA

## Ethernet sentences

**Input:** ACK, ACN (ACM), HBT

**Output:** ALC, ALF, ALR, ARC, DTM, GBS, GLL, GNS, GRS, GSA, GST, GSV, HBT, HDG, HDM, HDT\*<sup>1</sup>, HRM\*<sup>2</sup>, POS, RMC, ROT, THS, VBW\*<sup>2</sup>, VDR\*<sup>2</sup>, VHW\*<sup>2</sup>, VLW\*<sup>2</sup>, VTG, XDR\*<sup>2</sup>, ZDA

\*<sup>1</sup>: Not used for new SOLAS vessels.

\*<sup>2</sup>: For Non-IMO types only.

## Transmission Interval

Sentence	Available intervals
DTM*/GBS/GGA/GLL/GNS/GRS/GSA/GST/GSV/RMC/VBW/VDR/VHW/VLW/VTG/XDR/ZDA	0s, 1s, 2s
HDT/ROT/THS/HDG/HDM/HRM	20ms, 25ms, 100ms, 200ms, 1s, 2s
ALC/ALF/ALR/ARC/MSK	Fixed (Not changeable).

\*: Fixed for IMO type vessels.

## Load requirements as listener

Isolation: Photo coupler

Input impedance: 470 ohms

Max. voltage:  $\pm 15$  V

Threshold: 3 mA (in case of connection with FURUNO device talker)

## Data transmission

Data is transmitted in serial asynchronous form in accordance with the standard referenced in IEC 61162-1 and IEC 61162-2. The first bit is a start bit and is followed by data bits.

The following parameters are used:

Baud rate: 4800 for IEC 61162-1, 38400 for IEC 61162-2

Data bits: 8, parity = none

Stop bits: 1

Schematic diagrams

**Data ports 2 through 5**

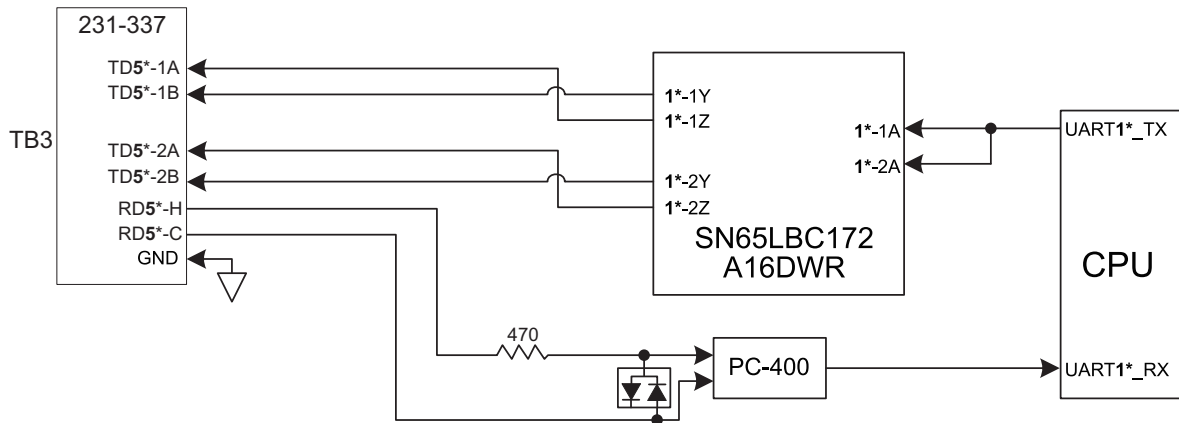

\*: Numerals in bold change as follows, with their respective terminal blocks.  
 TB4: **4**; TB5: **3**; TB6: **2**

**Data port 1**

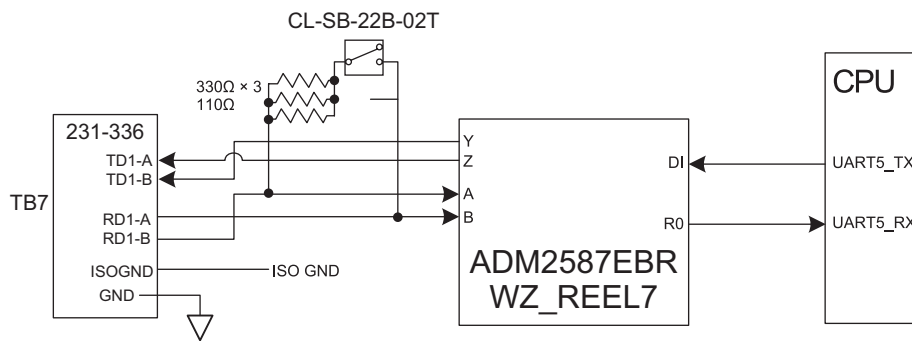

Sentence description (Input)

- ACK: Acknowledge Alarm  
 \$\*\*ACK,xxx,\*hh<CR><LF>  
     1  
 1. Local alarm number (identifier) (000 to 999)
- ACN (ACM): Alert Command  
 \$\*\*ACN,hhmmss.ss,aaa,x.x,x.x,c,a\*hh<CR><LF>  
     1      2  3  4  5  6  
 1. Time (UTC,unused)  
 2. Manufacturer mnemonic code (3 digits)  
 3. Alert Identifier (000 - 999999)  
 4. Alert Instance (1 - 999999,unused)  
 5. Alert command (A,Q,O,S)  
     A=acknowledge  
     Q=request/repeat information  
     O=responsibility transfer  
     S=silence  
 6. Sentence status flag(C) (fixed)

- HBT: Heartbeat Supervision Sentence

```
$**HBT,x.x,A,x*hh<CR><LF>
  1 2 3
```

1. Configured repeat interval (1 to 999(s))
2. Equipment status (A=Normal V=System fail)
3. Sequential sentence identifier (0 to 9)

- HDT: Heading, true

```
$**HDT,xxx.x,T*hh<CR><LF>
  1 2
```

1. Heading, degrees (0.0 to 360.0)
2. True (T)

- MSK: Receiver Interface Command

```
$**MSK,x.x,a,x.x,a,x.x,x,a *hh<CR><LF>
  1 2 3 4 5 6 7
```

1. Beacon frequency, kHz (283.45 to 325.04)
2. Auto/Manual frequency (See note 2) (A=Auto, M=Manual)
3. Beacon bit rate, bits/s (25, 50, 100, 150, 200)
4. Auto/Manual beacon bit rate (See note 2) (A=Auto, M=Manual)
5. Interval for sending \$\*\*MSS (status) in seconds (See note 1) (1 to 99, null)
6. Channel number (See note 3) (Fixed at 1)
7. Sentence status flag (See note 4) (R, C) (R= Sentence status is a report of current settings (use for a reply to a query, C= Sentence is a configuration command to change settings. A sentence without "C" is not a command.)

Notes:

- 1) When status data is not to be transmitted this field is "null".
- 2) If Auto is specified the previous field value is ignored.
- 3) Set equal to "1" or null for single channel receiver.
- 4) This field is used to indicate a sentence that is a status report of current settings or a configuration command changing settings. This field should not be null.

- MSS: MSK Receiver Signal Status

```
$**MSS,x.x,x.x,x.x,x.x,x *hh<CR><LF>
  1 2 3 4 5
```

1. Signal strength (SS), dB/(1 $\mu$ V/m) (0.0 to 999.94)
2. Signal-to-noise ratio (SN), dB (0.0 to 999.94)
3. Beacon frequency, kHz (283.5 to 325.04)
4. Beacon bit rate, bits/s (25, 50, 100, 200)
5. Channel number (1,null)(Set to "1" or "null" for single channel receivers.)

- THS: True Heading And Status

```
$**THS,x.x,a*hh<CR><LF>
  1 2
```

1. Heading, degrees True (0.0 to 360.0)
2. Mode indicator (A=Autonomous, S=Simulator)

- VBW: Dual Ground/water Speed

\$\*\*VBW,x.x,x.x,a,x.x,x.x,a,x.x,a,x.x,a\*hh<CR><LF>  
 1 2 3 4 5 6 7 8 9 10

1. Longitudinal water speed, knots (-999.994 to 999.994, null)
2. Transverse water speed, knots (-999.994 to 999.994, null)
3. Status: water speed (A=Data valid)
4. Longitudinal ground speed, knots (unused)
5. Transverse ground speed, knots (unused)
6. Status: ground speed, (A=Data valid, V=Data invalid)
7. Stern transverse water speed, knots (-999.994 to 999.994, null)
8. Status: stern water speed (A=Data valid)
9. Stern transverse ground speed, knots (unused)
10. Status: stern ground speed, (A=Data valid, V=Data invalid)

- VDR: Set and Drift

\$\*\*VDR,x.x,T,x.x,M,x.x,N\*hh <CR><LF>  
 1 2 3 4 5 6

1. Direction, degrees True (0.0 to 360.0,null)
2. T=True (fixed)
3. Direction, degrees Magnetic (0.0 to 360.0,null)
4. M=Magnetic (fixed)
5. Current speed (0 to 99.99)
6. N=Knots (fixed)

- Proprietary sentences: GPatt, GPhve, llals, pireq.

### Sentence description (Output)

- ALC: Cyclic Alert List

\$\*\*ALC,xx,xx,xx,x.x,aaa,x.x,x.x,x.x,\*\*\*\*\*hh<CR><LF>  
 1 2 3 4 5 6 7 8 9

1. Total number of sentences this message (01 to 99)
2. Sentence number (01 to 99)
3. Sequential message identifier (00 to 99)
4. Number of alert entries (0 to 2)
5. Manufacturer mnemonic code (FEC, null)
6. Alert identifier (000 to 999999)
7. Alert instance (1 to 999999)
8. Revision counter (1 to 99)
9. Additional alert entries (same as 5 to 8)

- ALF: Alert Sentence

\$\*\*ALF,x.x,x,hhmmss.ss,a,a,a,aaa,x.x,x.x,x.x,c--c\*hh<CR><LF>  
 1 2 3 4 5 6 7 8 9 10 11 12 13

1. Total number of ALF sentences this message (1, 2)
2. Sentence number (1, 2)
3. Sequential message identifier (0 to 9)
4. Time of last change (hh=00 to 23, mm=00 to 59, ss.ss=00.00 to 59.99), null
5. Alert category (B=Alert category B.), null when #2 is 2.
6. Alert priority (W=Warning, C=Caution), null when #2 is 2.
7. Alert state (V=Not ACKed, S=Silence, A=ACKed, O/U=Resolved, Not ACKed, N=Normal state), null when #2 is 2.
8. Manufacturer mnemonic code (FEC, null)
9. Alert identifier (000 to 999999)
10. Alert instance (1 to 999999)
11. Revision counter (1 to 99)
12. Escalation counter (0 to 9)
13. Alert text (when #2 =1: max. 16 characters; when #2=2: max. characters according to regulation)

- ALR: Set Alarm State

```
$**ALR,Hhmmss.ss,xxx,A,A,c—c*hh<CR><LF>
      1      2 3 4 5
```

1. Time of alarm condition change, UTC (000000.00 to 235959.99), null
2. Unique alarm number (identifier) at alarm source (000 to 999),null
3. Alarm condition (A=threshold exceeded, V=threshold not exceeded)
4. Alarm acknowledge state (A=acknowledged, V=not acknowledged)
5. Alarm description text (alphanumeric), null

- ARC: Alert Command Refused

```
$**ARC,hhmmss.ss,aaa,x.x,x.x,c*hh<CR><LF>
      1      2 3 4 5
```

1. Release time of the Alert Command Refused (UTC)
2. Used for proprietary alerts, defined by the manufacturer (FEC,null)
3. The alert identifier (000 to 999999)
4. The alert instance (1 to 999999)
5. Refused Alert Command(A, Q, O, S)  
A=acknowledge  
Q=request/repeat information  
O=responsibility transfer  
S=silence

- DTM: Datum Reference

```
$**DTM,ccc,a,x.x,a,x.x,a,x.x,ccc*hh<CR><LF>
      1 2 3 4 5 6 7 8
```

1. Local datum (W84:WGS84; W72:WGS72; P90:PZ90; User defined:999, IHO datum code)
2. Local datum subdivision code (null or one character)
3. Lat offset, minutes (0 to 59.9999)
4. N/S
5. Lon offset, min (0 to 59.9999)
6. E/W
7. Altitude offset, meters (null)
8. Reference datum (W84:WGS84; W72:WGS72; P90:PZ90)

- GBS: GNSS Satellite Fault Detection

```
$**GBS, hhmmss.ss, x.x, x.x, x.x, xx, x.x, x.x, x.x, h, h *hh<CR><LF>
      1      2 3 4 5 6 7 8 9 10
```

1. UTC time of GGA or GNS fix associated with this sentence (000000.00 to 235959.99),null
2. Expected error in latitude (0.00 to 999.99),null
3. Expected error in longitude (0.00 to 999.99),null
4. Expected error in altitude (0.00 to 999.99),null
5. ID number of most likely failed satellite (1 to 255),null
6. Probability of missed detection for most likely failed satellite (0.00 to 100.00),null
7. Estimate of bias in meters on most likely failed satellite (-999.99 to 999.99),null
8. Standard deviation of bias estimate (0.00 to 999.99), null
9. GNSS system ID (1 to F)
10. GNSS signal ID (0 to F)

- GGA - Global Positioning System Fix Data

\$\*\*GGA,hhmmss.ss,llll.lll,a,yyyyy.yyy,a,x,xx,x.x,x.x,M,x.x,M,x.x,xxxx\*hh<CR><LF>  
                   1      2  3      4      5 6 7  8   9 10 11 12 13 14

1. UTC of position (000000.00 to 235959.99)
2. Latitude (0000.0000 to 9000.00000)
3. N/S
4. Longitude (0000.0000 to 18000.00000)
5. E/W
6. GPS quality indicator (0 to 8)
7. Number of satellite in use (00 to 99)
8. Horizontal dilution of precision (0.0 to 99.9)
9. Antenna altitude above/below mean sea level (-9999 to 9999)
10. Unit, (Fixed at m)
11. Geoidal separation (-9999 to 9999)
12. Unit, (Fixed at m)
13. Age of differential GPS data (0 to 299) ,null
14. Differential reference station ID (0000 to 1023),null

- GLL: Geographic Position - Latitude/Longitude

\$\*\*GLL,llll.lll,a,yyyyy.yyy,a,hhmmss.ss,a,x\*hh<CR><LF>  
                   1  2      3      4      5      6 7

1. Latitude (0000.0000 to 9000.0000)
2. N/S
3. Longitude (0000.0000 to 18000.0000)
4. E/W
5. UTC of position (000000.00 to 235959.99)
6. Status (A=data valid V=data invalid)
7. Mode indicator (A=Autonomous, D=Differential, E=Estimated (dead reckoning), M=Manual input, S=Simulator, N=Data not valid )

- GNS: GNSS Fix Data

\$\*\*GNS,hhmmss.ss,llll.lll,a,lllll.lll,a,c--c,xx,x.x,x.x,x.x,x.x,x.x,a\*hh<CR><LF>  
                   1      2  3  4   5 6  7  8  9 10 11 12 13

1. UTC of position (000000.00 to 235959.99)
2. Latitude (0000.0000 to 9000.0000)
3. N/S
4. Longitude (0000.0000 to 18000.0000)
5. E/W
6. Mode indicator  
 N=No fix A=Autonomous D=Differential P=Precise R=Real Time Kinematic  
 F=Float RTK E=Estimated Mode M=Manual Input Mode S=Simulator Mode
7. Total number of satellites in use (00 to 99)
8. HDOP (0.0 to 50.0)
9. Antenna altitude, meters (-9999 to 9999)
10. Geoidal separation (-9999 to 9999)
11. Age of differential data (0 to 99)
12. Differential reference station ID (0000 to 1023)
13. Navigational status indicator  
 S=Safe C=Caution U=Unsafe V=Navigational status not valid



• GRS: GNSS Range Residual

\$\*\*GRS,hhmmss.ss,x,xx,xx,xx,xx,xx,xx,xx,xx,xx,xx,xx,h,h\*hh<CR><LF>

1. UTC time of GGA/GNS fix
2. Mode: 0=Residuals were used to calculate the position given in the matching GGA or GNS sentence; 1=Residuals were recomputed after the GGA or GNS position was computed
3. Range residuals in meters for satellites used in the navigation solution (-99 to 99, null) See notes 1&2.
- 4 to 14. Same as #3.
15. GNSS System ID (1 to F; 1=GP, 2=GL, 3=GA, 4 to F=RESERVED)
16. Signal ID (0 to F)

**Notes:**

- 1) If the range residual exceeds +99.9 meters, then the decimal part is dropped, resulting in an integer (-13.7 becomes -13). The maximum value for this field is +99.
- 2) The sense or sign of the range residual is determined by the order of parameters used in the calculation.  
The expected order is as follows: range residual = calculated range - measured range.
- 3) When multiple GRS sentences are being sent then their order of transmission must match the order of corresponding GSA sentences.  
Listeners shall keep track of pairs of GSA and GRS sentences and discard data if pairs are incomplete.
- 4) Signal ID identifies the actual ranging signal according to the Table below.
- 5) System ID according to Table below.

GRS Table

System	System ID	Satellite ID	Signal ID	Signal Channel
GPS	1 (GP)	1 to 99 1 to 32 is reserved for GPS 33 to 64 is reserved for SBAS 65 to 99 is undefined	0	All Signals
			1	L1 C/A
			2	L1 P(Y)
			3	L1 M
			4	L2 P(Y)
			5	L2C-M
			6	L2C-L
			7	L5-I
			8	L5-Q
	9 to F	Reserved		
GLONASS	2 (GL)	1 to 99 1 to 32 is undefined 33 to 64 is reserved for SBAS 65 to 99 is reserved for GLONASS	0	All Signals
			1	G1 C/A
			2	G1 P
			3	G2 C/A
			4	GLONASS (M) G2 P
	5 to F	Reserved		
GALILEO	3 (GA)	1 to 99 1 to 36 is reserved for Galileo SVs 37 to 64 is reserved for Galileo SBAS 65 to 99 is undefined	0	All Signals
			1	E5a
			2	E5b
			3	E5 a+b
			4	E6-A
			5	E6-BC
			6	L1-A
			7	L1-BC
	8 to F	Reserved		
Reserved	4 to F			

- GSA: GNSS DOP and Active Satellites

\$--GSA,a,x,xx,xx,xx,xx,xx,xx,xx,xx,xx,xx,x,x,x,x,x,h \*hh<CR><LF>  
 1 2 3 4 5 6 7

1. Mode (M=manual, forced to operate in 2=2D 3=3D mode  
 A=automatic, allowed to automatically switch 2D/3D)
2. Mode (1=fix not available 2=2D 3=3D)
3. ID number of satellites used in solution (01 to 96, null)
4. PDOP (0.0 to 50.0),null
5. HDOP (0.0 to 50.0),null
6. VDOP (0.0 to 50.0),null
7. GNSS System ID (See GRS table:System ID)

- GST: GNSS Pseudorange Error Statistics

\$\*\*GST,hhmmss.ss,x,x,x,x,x,x,x,x,x,x,x,x \*hh<CR><LF>  
 1 2 3 4 5 6 7 8

1. UTC time fo the GGA or GNS fix. (000000.00 to 235959.99)
2. RMS value of the standard deviation of the range inputs to the navigation process. Range inputs include pseudoranges & DGNSS corrections. (1 to 999, null)
3. Standard deviation of semi-major axis of error ellipse (meters) (0 to 655.34, null)
4. Standard deviation of semi-minor axis of error ellipse (meters) (0 to 655.34, null)
5. Orientation of semi-major axis of error ellipse (degrees from true north) (0 to 180, null)
6. Standard deviation of latitude error (meters) (0 to 999.9, null)
7. Standard deviation of longitude error (meters) (0 to 999.9, null)
8. Standard deviation of altitude error (meters) (0 to 999.9, null)

- GSV: GNSS Satellites in View

\$\*\*GSV,x,x,xx,xx,xx,xxx,xx,\_\_\_\_\_,xx,xx,xxx,xx, h \*hh<CR><LF>  
 1 2 3 4 5 6 7 8 9 10

1. Total number of messages (1 to 4)
2. Message number (1 to 4)
3. Total number of satellites in view (00 to 14)
4. Satellite ID number (01 to 96),null
5. Elevation, degrees (00 to 90),null
6. Azimuth, degrees true (000 to 359),null
7. SNR(C/No) (00 to 99(dB-Hz), null when not tracking)
8. Second and third SVs
9. Fourth SV
10. Signal ID (See GRS table:Signal ID)

- HBT - Heartbeat Supervision Sentence

\$\*\*HBT,x,x,A,x\*hh<CR><LF>  
 1 2 3

1. Configured repeat interval (50.0(s))(+1)
2. Equipment status (A=Normal)
3. Sequential sentence identifier (0 to 9)

- HDG: Heading, Deviation and Variation

\$\*\*HDG,x,x,x,x,a,x,x,a\*hh<CR><LF>  
 1 2 3 4 5

1. Magnetic sensor heading, degrees (0.0 to 359.9)
2. Magnetic deviation, degrees (0.0 to 180.0)
3. E/W
4. Magnetic variation, degrees (0.0 to 180.00)
5. E/W

- HDM: Heading, Magnetic

```
$**HDM,x.x,M*hh<CR><LF>
  1 2
```

1. Heading, degrees (0.0 to 359.9)
2. Magnetic (M)

- HDT: Heading, True

```
$**HDT,xxx.x,T*hh<CR><LF>
  1 2
```

1. Heading, degrees (0.0 to 359.9)
2. True (T)

- HRM: Heel Angle, Roll Period and Roll Amplitude Measurement Device

```
$**HRM,hhmmss.ss,x.x,x.x,x.x,A,x.x,x.x,hhmmss.ss,x.x,x.x *hh<CR><LF>
  1 2 3 4 5 6 7 8 9 10
```

1. Actual heel angle, degrees (-89.999 to 89.999, null)
2. Roll period, seconds (0 to 99.9, null)
3. Roll amplitude, port side, degrees (0 to 89.999, null)
4. Roll amplitude, starboard side, degrees (0 to 89.999, null)
5. Status (A/V) A=Data valid, V=Data invalid
6. Roll peak hold value, port side, degrees (null)
7. Roll peak hold value, starboard side, degrees (null)
8. Peak hold value reset time (fixed at null)
9. Peak hold value reset day (fixed at null)
10. Peak hold value reset month (fixed at null)

- MSK: Receiver Interface Command

```
$**MSK,x.x,a,x.x,a,x.x,x,a *hh<CR><LF>
  1 2 3 4 5 6 7
```

1. Beacon frequency, kHz (283.5 to 325.0, null)
2. Auto/Manual frequency (See note 2) (A=Auto, M=Manual)
3. Beacon bit rate, bits/s (25, 50, 100, 150, 200, null)
4. Auto/Manual beacon bit rate (See note 2) (A=Auto, M=Manual)
5. Interval for sending \$\*\*MSS (status) in seconds (See note 1) (Fixed at 5)
6. Channel number (See note 3) (Fixed at 1)
7. Sentence status flag (See note 4) (C - Sentence is a configuration command to change settings. A sentence without "C" is not a command.)

Notes:

- 1) When status data is not to be transmitted this field is "null".
- 2) If Auto is specified the previous field value is ignored.
- 3) Set equal to "1" or null for single channel receiver.
- 4) This field is used to indicate a sentence that is a status report of current settings or a configuration command changing settings. This field should not be null.

- POS: Device Position and Ship Dimensions Report or Confirmation Command

\$\*\*POS,cc,xx,a,x.x,x.x,x.x,a,x.x,x.x,a\*hh<CR><LF>

1 2 3 4 5 6 7 8 9 10

1. Equipment ID (GP, GL, GA, GN, HE, HN, HC)
2. Equipment number (01 to 99)
3. Position validity flag (A=Valid V=Invalid)
4. Position X-coordinate (-999.9 to 999.9)
5. Position Y-coordinate (0 to 999.9)
6. Position Z-coordinate (0 to 999.9)
7. Ship's width and length (A=Valid)
8. Ship's width (000.0 to 999.9)
9. Ship's length (000.0 to 999.9)
10. Sentence status flag (R=Sentence is status report of current settings)

- RMC: Recommended Minimum Specific GNSS Data

\$\*\*RMC,hhmmss.ss,A,llll.ll,a,yyyy.yy,a,x.x,x.x,ddmmyy,x.x,a,a\*hh<CR><LF>

1 2 3 4 5 6 7 8 9 10 11 12 13

1. UTC of position fix (000000.00 to 235959.99)
2. Status (A=data valid, V=navigation receiver warning)
3. Latitude (0000.0000 to 9000.0000)
4. N/S
5. Longitude (0000.0000 to 18000.0000)
6. E/W
7. Speed over ground, knots (0.000 to 9999.999)
8. Course over ground, degrees true (0.0 to 359.9)
9. Date (010100 to 311299)
10. Magnetic variation, degrees (0.0 to 180.0,null)
11. E/W (E/W,null)
12. Mode indicator (A= Autonomous mode, D=Differential mode, E=Estimated (DR), S= Simulator, M=Manual, N=Data not valid, P=Precise)
13. Navigational status indication (S=Safe C=Caution U=Unsafe V=Navigational status not valid)

- ROT: Rate of Turn

\$\*\*ROT,x.x,A \*hh<CR><LF>

1 2

1. Rate of turn, deg/min, "-"=bow turns to port (-9999.9 - 9999.9,null)
2. Status (A=data valid, V=data invalid)

- THS: True Heading & Status

\$\*\*THS,x.x,a\*hh<CR><LF>

1 2

1. Heading, degrees True (0.0 to 359.9 null)
2. Mode indicator (A=Autonomous, E=Estimated, M=Manual input, S=Simulator V=Data not valid)

- VBW: Dual Ground/Water Speed

```
$**VBW,x.x,x.x,a,x.x,x.x,a,x.x,a,x.x,a*hh<CR><LF>
  1 2 3 4 5 6 7 8 9 10
```

1. Longitudinal water speed, knots (-999.999 to 999.999),null
2. Transverse water speed, knots (-999.999 to 999.999),null
3. Status: water speed, A=Data valid V=Data invalid
4. Longitudinal ground speed, knots (-999.999 to 999.999),null
5. Transverse ground speed, knots (-999.999 to 999.999),null
6. Status: ground speed, A=Data valid V=Data invalid
7. Stern transverse water speed, knots (-999.999 to 999.999),null
8. Status: stern water speed, A=Data valid V=Data invalid
9. Stern transverse ground speed, knots (-999.999 to 999.999),null
10. Status: stern ground speed, A=Data valid V=Data invalid

- VDR: Set and Drift

```
$**VDR,x.x,T,x.x,M,x.x,N*hh <CR><LF>
  1 2 3 4 5 6
```

1. Direction, degrees (0.0 to 359.9),null
2. T=True (fixed)
3. Direction, degrees (0.0 to 359.9),null
4. M=Magnetic (fixed)
5. Current speed (0 to 99.99),null
6. N=Knots (fixed)

- VHW: Water Speed and Heading

```
$**VHW,x.x,T,x.x,M,x.x,N,x.x,K,*hh <CR><LF>
  1 2 3 4 5 6 7 8
```

1. Heading, degrees (0.000 to 359.999, null)
2. T=True (fixed)
3. Heading, degrees (0.000 to 359.999, null)
4. M=Magnetic (fixed)
5. Speed, knots (-999.999 to 999.999, null)
6. N=Knots (fixed)
7. Speed, km/hr (-999.999 to 999.999, null)
8. K=km/hr (fixed)

- VLW: Dual Ground/Water Distance

```
$**VLW,x.x,N,x.x,N,x.x,N,x.x,N*hh<CR><LF>
  1 2 3 4 5 6 7 8
```

1. Total cumulative water distance (null)
2. N=Nautical miles
3. Water distance since reset (null)
4. N=Nautical miles
5. Total cumulative ground distance (null)
6. N=Nautical miles
7. Ground distance since reset (0.00 to 999999.99)
8. N=Nautical miles

- VTG: Course Over Ground and Ground Speed

\$\*\*VTG,x.x,T,x.x,M,x.x,N,x.x,K,a\*hh <CR><LF>  
 1 2 3 4 5 6 7 8 9

1. Course over ground, degrees (0.0 to 359.9),null
2. T=True (fixed)
3. Course over ground, degrees (0.0 to 359.9),null
4. M=Magnetic (fixed)
5. Speed over ground, knots (0.0 to 999.9),null
6. N=Knots (fixed)
7. Speed over ground (0.0 to 999.9),null
8. K=km/h (fixed)
9. Mode indicator (A=Autonomous, D=Differential, E=Estimated (dead reckoning), M=Manual input, S=Simulator, N=Data not valid, P=Precise)

- XDR: Transducer Measurements

\$\*\*XDR, a, x.x, a, c--c, a, x.x, a, c--c \*hh<CR><LF>  
 1 2 3 4 5 6 7 8

1. Transducer type, transducer no. 1 (C=Celcius, fixed)
2. Measurement data, transducer no. 1 (-50.00 to 99.99)
3. Units of measure (C=Celcuis, fixed)
4. Transducer no.1 ID (AIRT, fixed)
5. Transducer type, transducer no. 2 (P=Pressure, fixed)
6. Measurement data, transducer no. 2 (0.00 to 120000.00)
7. Units of measure (P=Pascal, fixed)
8. Transducer no.2 ID (AIRP, fixed)

- ZDA: Time and date

\$\*\*ZDA, hhmmss.ss, xx, xx, xxxx, xx, xx<CR><LF>  
 1 2 3 4 5 6

1. UTC (000000.00 to 235959.99)
2. Day (01 to 31)
3. Month (01 to 12)
4. Year (UTC, 0000 to 9999)
5. Local zone, hours (-14 to +14)
6. Local zone, minutes (00 to +59)

# APPENDIX 8 PARTS LIST/LOCATION

## Parts List

This equipment contains complex modules in which fault diagnosis and repair down to component level are not practical (IMO A.694(17)/8.3.1). Only some discrete components are used. FURUNO Electric Co., Ltd. believes identifying these components is of no value for shipboard maintenance; therefore, they are not listed in the manual. Major modules can be located on the parts location figures below.

<b>FURUNO</b>	Model	SC-70/SC-130
<b>ELECTRICAL PARTS LIST</b>	Unit	DISPLAY UNIT, JUNCTION BOX,
<b>TYPE, NAME</b>	<b>LOCATION</b>	
<b>PRINTED CIRCUIT BOARD</b>		
20P8200E, MAIN	DISPLAY UNIT SC-702	
05P0894A, C-IF	DISPLAY UNIT SC-702	
20P8232, MAIN	JUNCTION BOX SC-701	
20P8233, TB_PWR	JUNCTION BOX SC-701	
20P8229A, LAN_CNV	JUNCTION BOX SC-701	

PCB locations for SC-701

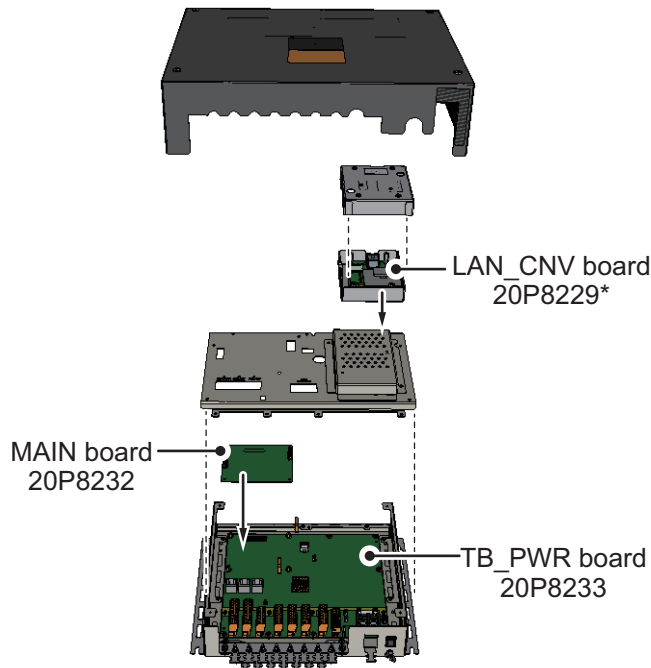

PCB locations for SC-702

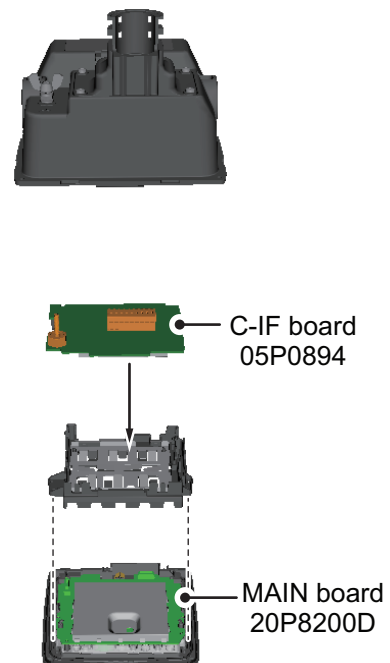

\*: Optional LAN to Coax conversion kit.

Note: SC-701 and SC-702 are not shown to scale in this figure.

<b>FURUNO</b>	Model	SC-703
<b>ELECTRICAL PARTS LIST</b>	Unit	ANTENNA UNIT
TYPE, NAME	LOCATION	
PRINTED CIRCUIT BOARD		
20P8228A, MAIN	ANTENNA UNIT SC-703	
20P8222A, GNSS_LNA	ANTENNA UNIT SC-703	
20P8229B, LAN_CNV	ANTENNA UNIT SC-703	
20P8230, SUB_IMU	ANTENNA UNIT SC-703	

PCB locations for SC-703

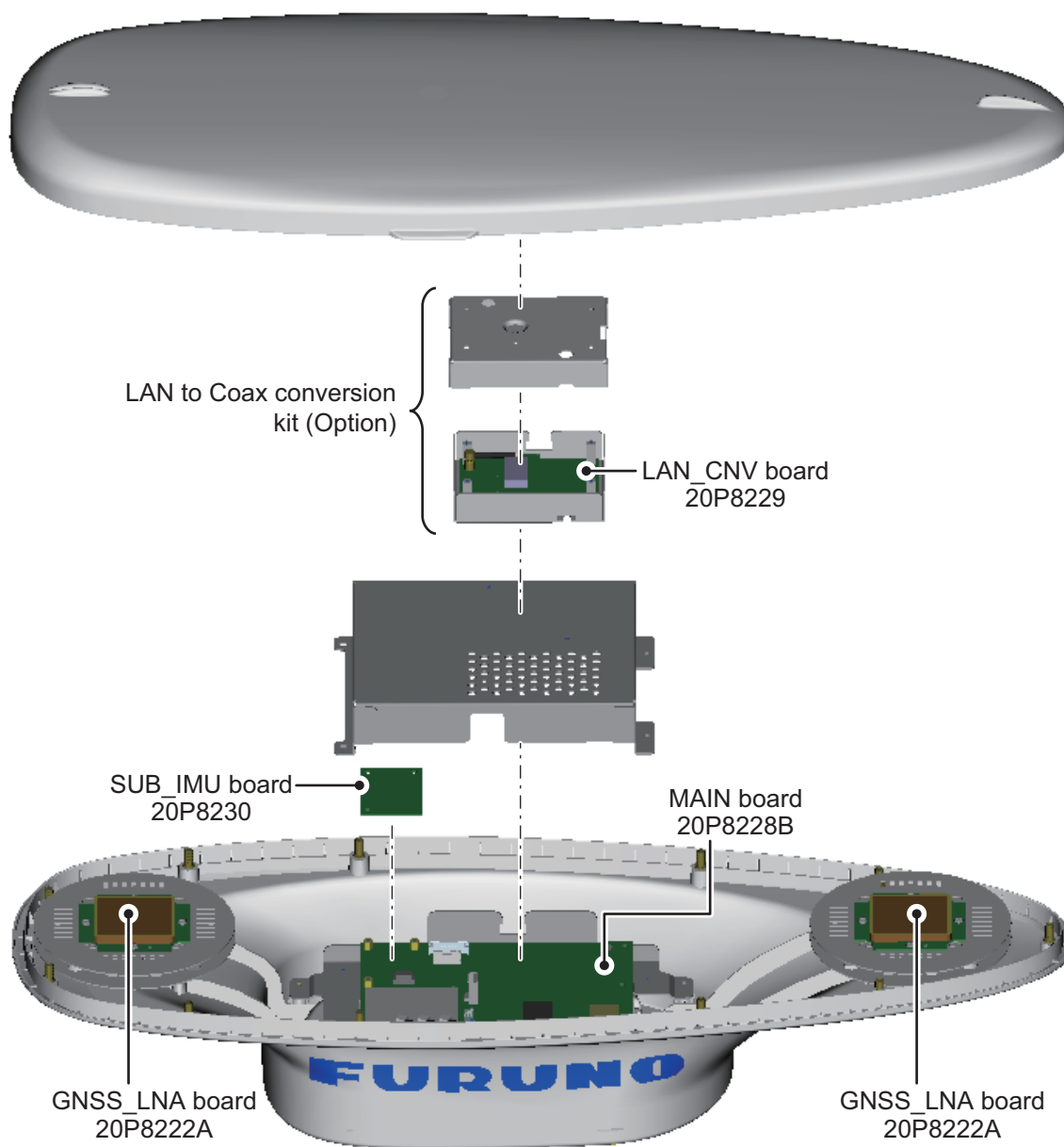



<b>FURUNO</b> ELECTRICAL PARTS LIST	Model	SC-1303
	Unit	ANTENNA UNIT
TYPE, NAME	LOCATION	
PRINTED CIRCUIT BOARD		
20P8228B, MAIN	ANTENNA UNIT SC-1303	
20P8222A, GNSS LNA	ANTENNA UNIT SC-1303	
20P8229B, LAN_CNV	ANTENNA UNIT SC-1303	
20P8230, SUB_IMU	ANTENNA UNIT SC-1303	

PCB locations for SC-1303

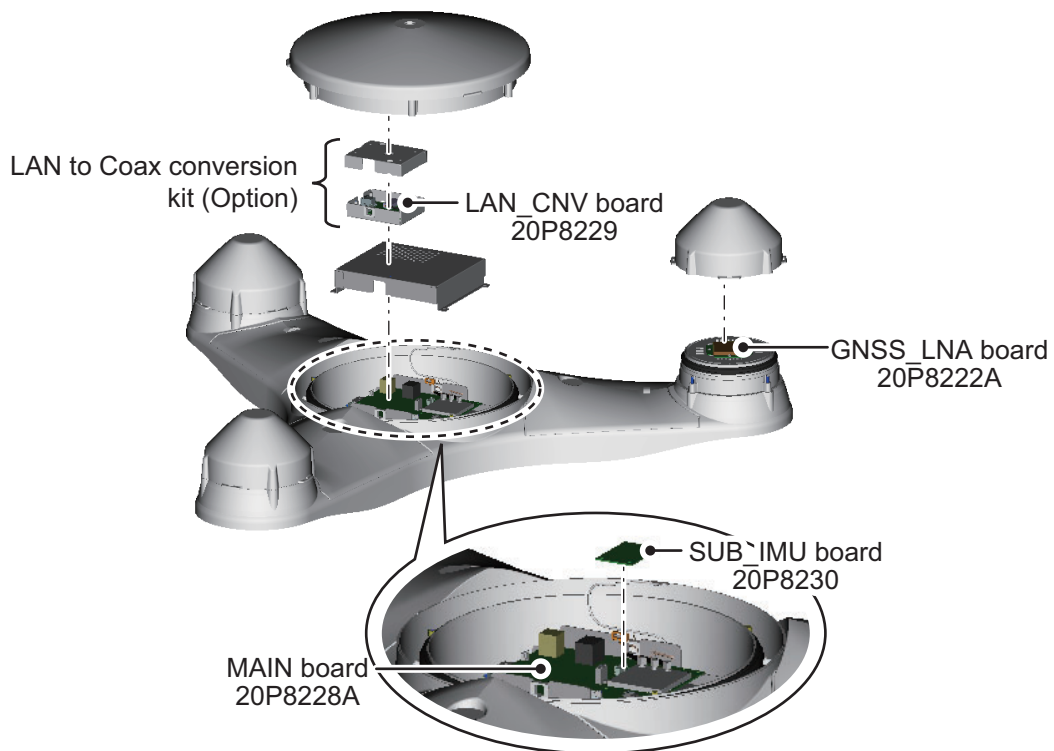

# APPENDIX 9 JIS CABLE GUIDE

Cables listed in the manual are usually shown as Japanese Industrial Standard (JIS). Use the following guide to locate an equivalent cable locally.

JIS cable names may have up to 6 alphabetical characters, followed by a dash and a numerical value (example: DPYC-2.5).

For core types D and T, the numerical designation indicates the *cross-sectional Area (mm<sup>2</sup>)* of the core wire(s) in the cable.

For core types M and TT, the numerical designation indicates the *number of core wires* in the cable.

## 1. Core Type

D: Double core power line

T: Triple core power line

M: Multi core

TT: Twisted pair communications  
(1Q=quad cable)

## 2. Insulation Type

P: Ethylene Propylene

Rubber

## 3. Sheath Type

Y: PVC (Vinyl)

## 4. Armor Type

C: Steel

## 5. Sheath Type

Y: Anticorrosive vinyl sheath

## 6. Shielding Type

S: All cores in one sheath

-S: Individually sheathed cores

SLA: All cores in one shield, plastic tape w/aluminum tape

-SLA: Individually shielded cores, plastic tape w/aluminum tape



EX: <sup>1 2 3 4 5 6</sup> TTYC Y S L A - 4  
 Designation type    # of twisted pairs

EX: <sup>1 2 3 4</sup> M P Y C - 4  
 Designation type    # of cores

The following reference table lists gives the measurements of JIS cables commonly used with Furuno products:

Type	Core Area	Core Diameter	Cable Diameter	Type	Core Area	Core Diameter	Cable Diameter
DPYC-1.5	1.5mm <sup>2</sup>	1.56mm	11.7mm	TTYCS-1	0.75mm <sup>2</sup>	1.11mm	10.1mm
DPYC-2.5	2.5mm <sup>2</sup>	2.01mm	12.8mm	TTYCS-1T	0.75mm <sup>2</sup>	1.11mm	10.6mm
DPYC-4	4.0mm <sup>2</sup>	2.55mm	13.9mm	TTYCS-1Q	0.75mm <sup>2</sup>	1.11mm	11.3mm
DPYC-6	6.0mm <sup>2</sup>	3.12mm	15.2mm	TTYCS-4	0.75mm <sup>2</sup>	1.11mm	16.3mm
DPYC-10	10.0mm <sup>2</sup>	4.05mm	17.1mm	TTYCSLA-1	0.75mm <sup>2</sup>	1.11mm	9.4mm
DPYCY-1.5	1.5mm <sup>2</sup>	1.56mm	13.7mm	TTYCSLA-1T	0.75mm <sup>2</sup>	1.11mm	10.1mm
DPYCY-2.5	2.5mm <sup>2</sup>	2.01mm	14.8mm	TTYCSLA-1Q	0.75mm <sup>2</sup>	1.11mm	10.8mm
DPYCY-4	4.0mm <sup>2</sup>	2.55mm	15.9mm	TTYCSLA-4	0.75mm <sup>2</sup>	1.11mm	15.7mm
MPYC-2	1.0mm <sup>2</sup>	1.29mm	10.0mm	TTYCY-1	0.75mm <sup>2</sup>	1.11mm	11.0mm
MPYC-4	1.0mm <sup>2</sup>	1.29mm	11.2mm	TTYCY-1T	0.75mm <sup>2</sup>	1.11mm	11.7mm
MPYC-7	1.0mm <sup>2</sup>	1.29mm	13.2mm	TTYCY-1Q	0.75mm <sup>2</sup>	1.11mm	12.6mm
MPYC-12	1.0mm <sup>2</sup>	1.29mm	16.8mm	TTYCY-4	0.75mm <sup>2</sup>	1.11mm	17.7mm
TPYC-1.5	1.5mm <sup>2</sup>	1.56mm	12.5mm	TTYCY-4S	0.75mm <sup>2</sup>	1.11mm	21.1mm
TPYC-2.5	2.5mm <sup>2</sup>	2.01mm	13.5mm	TTYCY-4SLA	0.75mm <sup>2</sup>	1.11mm	19.5mm
TPYC-4	4.0mm <sup>2</sup>	2.55mm	14.7mm	TTYCYS-1	0.75mm <sup>2</sup>	1.11mm	12.1mm
TPYCY-1.5	1.5mm <sup>2</sup>	1.56mm	14.5mm	TTYCYS-4	0.75mm <sup>2</sup>	1.11mm	18.5mm
TPYCY-2.5	2.5mm <sup>2</sup>	2.01mm	15.5mm	TTYCYSLA-1	0.75mm <sup>2</sup>	1.11mm	11.2mm
TPYCY-4	4.0mm <sup>2</sup>	2.55mm	16.9mm	TTYCYSLA-4	0.75mm <sup>2</sup>	1.11mm	17.9mm

**SPECIFICATIONS OF SATELLITE COMPASS  
SC-70/130**

**1 GENERAL**

- |      |   |  |
|------|---|--|
| 1.1  | Receiving frequency   | 1575.42 MHz (GPS/GALILEO), 1602.5625 MHz (GLONASS)   |
| 1.2  | Tracking code   | C/A code (GPS), E1B (GALILEO), 10F (GLONASS)   |
| 1.3  | Positional accuracy (dependent on ionospheric activity and multipath) |  |
|      | GPS   | 10 m approx. (2drms, HDOP<4)   |
|      | DGPS  | 5 m approx. (2drms, HDOP<4)  |
|      | WAAS  | 3 m approx. (2drms, HDOP<4)  |
|      | MSAS  | 7 m approx. (2drms, HDOP<4)  |
| 1.4  | Ship's speed accuracy (SOG)   |  |
|      |   | 0.2 kn rms (tracking satellites 3 or 4)  |
|      |   | 0.02 kn rms (tracking satellites 5 or more)  |
| 1.5  | Ship's speed accuracy (VBW, speed on ground)                          |  |
|      |   | 2.0% of ship's speed or 0.2 kn whichever is the greater<br>(tracking satellites 3 or 4)                          |
|      |   | 0.2% of ship's speed or 0.02 kn whichever is the greater<br>(tracking satellites 5 or more, at antenna position) |
|      |   | 0.2% of ship's speed or 0.08 kn rms<br>(tracking satellites 5 or more, at another position)                      |
| 1.6  | Course accuracy   |  |
|      | SC-70   | 0.4° RMS   |
|      | SC-130  | 0.25° RMS  |
| 1.7  | Course resolution   | 0.1°, 0.01° or 0.001° (select from menu)   |
| 1.8  | Attitude resolution   | 0.1°, 0.01° or 0.001° (select from menu)   |
| 1.9  | Rate of turn  | 0.1°/s, 0.01°/s or 0.001°/s (select from menu)   |
| 1.10 | Tracking bearing  | 40°/s  |
| 1.11 | Position fixing time  | 90 s approx. (typical)   |
| 1.12 | Attitude accuracy   | Pitch/ Roll: 0.4° RMS  |

**2 DISPLAY UNIT**

- |     |                  |   |
|-----|------------------|---|
| 2.1 | Screen           | 4.3-inch color LCD, 95.04 mm (W) x 87.12 mm (H)               |
| 2.2 | Resolution       | 480 x 272 dots (WQVGA)  |
| 2.3 | Brilliance       | 600 cd/m <sup>2</sup> typical                                 |
| 2.4 | Contrast         | 17 levels   |
| 2.5 | Display mode     | Heading, Nav data, Rate of turn and Speed (Non-IMO mode only) |
| 2.6 | Visible distance | 0.65 m nominal  |

**3 INTERFACE (JUNCTION BOX)**

- |     |                                |   |
|-----|--------------------------------|---|
| 3.1 | Number of ports (junction box) |   |
|     | IEC61162 (NMEA0183)            | IEC61162-2: 1 port, IEC61162-1: 8 ports (I/O: 4, O: 4)                              |
|     |                                | External beacon input (DATA5 port):<br>RTCM SC-104 V2.3 (RS-485), ITU-R M823        |
|     | CANbus                         | 1 port  |
|     | AD-10                          | 4 ports, for heading output   |
|     | RS-485                         | 1 port, for display unit connection   |
|     | LAN                            | 2 ports, Ethernet, 100Base-TX, RJ45 connector<br>(for IEC61162-450 and maintenance) |

- USB 1 port for maintenance
- 3.2 Data sentences
  - DATA ports
    - Input ACK, ACM, ACN, HBT, HDT, MSK, MSS, THS, VBW\*<sup>2</sup>, VDR\*<sup>2</sup>
    - Output ALC, ALF, ALR, ARC, DTM, GBS, GGA, GLL, GNS, GRS, GSA, GST, GSV, HBT, HDG\*<sup>2</sup>, HDM\*<sup>2</sup>, HDT\*<sup>1</sup>, HRM\*<sup>2</sup>, MSK, POS, RMC, ROT, THS, VBW\*<sup>2</sup>, VDR\*<sup>2</sup>, VHW\*<sup>2</sup>, VLW\*<sup>2</sup>, VTG, XDR\*<sup>2</sup>, ZDA
  - NETWORK port
    - Input ACK, ACM, ACN, HBT
    - Output ALC, ALF, ALR, ARC, DTM, GBS, GGA, GLL, GNS, GRS, GSA, GST, GSV, HBT, HDG, HDM, HDT\*<sup>1</sup>, HRM\*<sup>2</sup>, POS, RMC, ROT, THS, VBW\*<sup>2</sup>, VDR\*<sup>2</sup>, VHW\*<sup>2</sup>, VLW\*<sup>2</sup>, VTG, XDR\*<sup>2</sup>, ZDA
- \*<sup>1</sup>: Not used for new SOLAS vessels.
- \*<sup>2</sup>: for Non-IMO types only.
- 3.3 Output proprietary sentences
  - PFEC GPatt, GPhve, GPimu, pidat, pireq
- 3.4 PGN
  - Input 059392/904, 060928, 061184, 126208/720/996
  - Output 059392/904, 060928, 061184, 065280, 126208/464/720/992/996, 127250/251/252/257/258, 129025/026/029/033/044/291/539/540/545/547, 130310/312/314/316/577/578/822/823/842/843/845/846
- 3.5 IEC61162-450 transmission group
  - Input MISC, SATD, NAVD, PROP
  - Output Arbitrary (default: SATD)
- 3.6 Other network function excepted IEC61162-450
  - NTP, HTTP

## 4 POWER SUPPLY

- 4.1 Junction box 12-24 VDC: 2.1-1.1 A (included antenna unit and display unit)
- 4.2 Rectifier (PR-240, option) 100-115/220-230 VAC, 1 phase, 50/60Hz and 24VDC

## 5 ENVIRONMENTAL CONDITIONS

- 5.1 Ambient temperature
  - Antenna unit -25°C to +55°C (storage: -25°C to +70°C )
  - Display unit/ Junction box -15°C to +55°C
- 5.2 Relative humidity 95% or less at +40°C
- 5.3 Degree of protection
  - Antenna unit IP56
  - Display unit IP22 (IP35: option)
  - Junction box IP20 (IP22: bulkhead mount)
- 5.4 Vibration IEC 60945 Ed.4

## 6 UNIT COLOR

- 6.1 Antenna unit N9.5
- 6.2 Display unit/ Junction box N2.5

# **FURUNO**



This page is intentionally left blank.

# PACKING LIST

2081-X-9857 -2 1/1

SC-703-\*, SC-703-\*\*HK

A-1

NAME	OUTLINE	DESCRIPTION/CODE No.	QTY
ユニット 空中線部 ANTENNA UNIT		SC-703-* 000-030-905-00 **	1
工事材料 INSTALLATION MATERIALS		CP20-04201 001-459-750-00 **	1

コード番号末尾の[\*\*]は、選用品の代表コードを表します。  
CODE NUMBER ENDING WITH "\*\*" INDICATES THE CODE NUMBER OF REPRESENTATIVE MATERIAL.

(略図の寸法は、参考値です。 DIMENSIONS IN DRAWING FOR REFERENCE ONLY.)



C7282-Z07-C

# PACKING LIST

2081-X-9859 -1 1/1

SC-1303-\*, SC-1303-\*\*HK

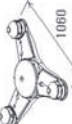
A-2

NAME	OUTLINE	DESCRIPTION/CODE No.	QTY
ユニット 空中線部 ANTENNA UNIT		SC-1303-* 000-030-909-00 **	1
工事材料 INSTALLATION MATERIALS		CP20-04202 001-459-760-00 **	1

コード番号末尾の[\*\*]は、選用品の代表コードを表します。  
CODE NUMBER ENDING WITH "\*\*" INDICATES THE CODE NUMBER OF REPRESENTATIVE MATERIAL.

(略図の寸法は、参考値です。 DIMENSIONS IN DRAWING FOR REFERENCE ONLY.)



C7283-Z01-B

# PACKING LIST

2081-X-9851 -1 1/1

SC-701-\*, SC-701-\*-HK-\*

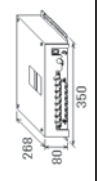
A-3

NAME	OUTLINE	DESCRIPTION/CODE No.	QTY
<b>ユニット UNIT</b>			
接続箱 JUNCTION BOX		SC-701-*	1
<b>予備品 SPARE PARTS</b>			
予備品 SPARE PARTS		SP20-01801	1
<b>工事材料 INSTALLATION MATERIALS</b>			
工事材料 INSTALLATION MATERIALS		CP20-04001	1
000-030-842-00 **			
001-459-600-00 **			

コード番号末尾の[\*\*]は、選用品の代表コードを表します。  
CODE NUMBER ENDING WITH "\*\*" INDICATES THE CODE NUMBER OF REPRESENTATIVE MATERIAL.

(略図の寸法は、参考値です。 DIMENSIONS IN DRAWING FOR REFERENCE ONLY.)



C7282-Z01-B

# PACKING LIST

2081-X-9863 -2 1/1

SC-702-\*, SC-702-\*-HK

A-4

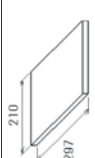
NAME	OUTLINE	DESCRIPTION/CODE No.	QTY
<b>ユニット UNIT</b>			
表示部 DISPLAY UNIT		SC-702-*	1
<b>付属品 ACCESSORIES</b>			
付属品 ACCESSORIES		FP19-01201	1
<b>工事材料 INSTALLATION MATERIALS</b>			
工事材料 INSTALLATION MATERIALS		CP20-04101	1
000-030-882-00 **			
001-033-760-00 **			
<b>図書 DOCUMENT</b>			
取扱説明書 OPERATOR'S MANUAL		000-72820-*	1
000-192-405-1* **			

コード番号末尾の[\*\*]は、選用品の代表コードを表します。  
CODE NUMBER ENDING WITH "\*\*" INDICATES THE CODE NUMBER OF REPRESENTATIVE MATERIAL.

(略図の寸法は、参考値です。 DIMENSIONS IN DRAWING FOR REFERENCE ONLY.)

C7282-Z11-C

# PACKING LIST

2081-X-9854 -2 1/1

SC-702-\*\*-1/3, SC-702-\*\*-1/3-HK

A-5

NAME	UNIT	DESCRIPTION/CODE No.	QTY
<b>ユニット</b>			
表示部 DISPLAY UNIT		SC-702-** 000-030-882-00 **	1
<b>付属品</b>			
付属品 ACCESSORIES		FP19-01201 001-033-760-00 **	1
<b>工事材料</b>			
<b>ケーブル組品</b>			
CABLE ASSEMBLY		Z-#26X2P+0.3S0X1PL10 000-192-276-10	1 (*)
CABLE ASSEMBLY		Z-#26X2P+0.3S0X1PL30 000-192-277-10	1 (*)
<b>工事材料</b>			
<b>INSTALLATION MATERIALS</b>			
取扱説明書 OPERATOR'S MANUAL		01** 72820-** 000-192-405-1* **	1

1.コード番号末尾の(\*\*)は、選用品の代表コードを表します。  
CODE NUMBER ENDING WITH "\*\*" INDICATES THE CODE NUMBER OF REPRESENTATIVE MATERIAL.  
2.(\*)は、それぞれ仕様選用品を表します。  
(\*)INDICATE SPECIFICATION SELECTIVE ITEM.

(略図の寸法は、参考値です。 DIMENSIONS IN DRAWING FOR REFERENCE ONLY.)

C7282-Z04-C

# FURUNO

A-6

CODE NO.	001-514-470-00	2081-X-9410 -0			
TYPE	CP20-04001	1/1			
<b>工事材料表</b>					
<b>INSTALLATION MATERIALS</b>					
番号 NO.	名称 NAME	略図 OUTLINE	型名/規格 DESCRIPTIONS	数量 QTY	用途/備考 REMARKS
1	ケーブルチューブ A INSULATION TUBE		3.0X0.3 YEL *500M* CODE NO. 000-162-841-10	3	
2	+573カギ'ボタ' 1/2 SELF-TAPPING SCREW		5X20 SUS304 CODE NO. 000-162-608-10	4	
3	ケーブルタイ CABLE TIE		CV-150N CODE NO. 000-162-18E-10	32	

(略図の寸法は、参考値です。 DIMENSIONS IN DRAWING FOR REFERENCE ONLY.)

FURUNO ELECTRIC CO., LTD.

ON

C7282-M10-A



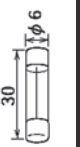
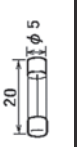

CODE NO.	001-516-680-00	2081-X-9303-0	1/1
TYPE	SP20-01801	BOX NO.	P

SHIP NO.	SPARE PARTS LIST FOR		U S E		REMARKS/CODE NO.	
			PER SET	QUANTITY PER VESSEL		
ITEM NO.	NAME OF PART	DWG. NO. OR TYPE NO.	OUTLINE	WORKING	SPARE	SETS PER VESSEL
1	ガラス GLASS TUBE FUSE	FG60-A 125V 3A PBF		1	3	
2	ガラス GLASS TUBE FUSE	FG6R 125V 0.3A PBF		1	3	
MFR'S NAME	FURUNO ELECTRIC CO., LTD.		DWG NO.	C7282-P02-A CN		1/1

(略図の寸法は、参考値です。 DIMENSIONS IN DRAWING FOR REFERENCE ONLY.)

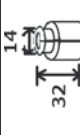

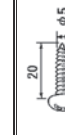
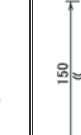

CODE NO.	001-521-480-00	2081-X-9414-0
TYPE	CP20-04101	1/1

工事材料表				数量 QTY	用途/備考 REMARKS
INSTALLATION MATERIALS					
番号 NO.	名称 NAME	略図 OUTLINE	型名/規格 DESCRIPTIONS		
1	F_MOUNT CUSHION		20-032-1064-1	1	
2	ケーブル'ガク' ケーブル CABLE GASKET		100-357-181-10	1	
3	セルフ'タッピン' スクリュー SELF-TAPPING SCREW		3X20 SUS304	4	
4	セルフ'タッピン' スクリュー SELF-TAPPING SCREW		5X20 SUS304	4	
5	ケーブル'ガク' ケーブル CABLE TIE		CV-150B	3	

(略図の寸法は、参考値です。 DIMENSIONS IN DRAWING FOR REFERENCE ONLY.)

CODE NO.	001-514-460-00	2081-X-9411-1	1/1
TYPE	CP20-04201		

## 工事材料表

番号 NO.	名称 NAME	略図 OUTLINE	型名/規格 DESCRIPTIONS	数量 QTY	用途/備考 REMARKS
1	鳥除け BIRD DETERRENT		ZD-024-3101-3 R0HS 100-315-303-10	4	
2	六角ナット 1/2 HEX. NUT		M10 SUS304 000-166-475-10	8	
3	ハネばね SPRING WASHER		M10 SUS304 000-167-233-10	4	
4	平座金 FLAT WASHER		M10 SUS316L 000-167-416-10	4	
5	接着剤袋詰 ADHESIVE		TB5211 50G 001-517-370-00	1	

(略図の寸法は、参考値です。 DIMENSIONS IN DRAWING FOR REFERENCE ONLY.)





FURUNO ELECTRIC CO., LTD.

CN

C7282-M11-B

CODE NO.	001-514-570-00	2081-X-9412-1	1/1
TYPE	CP20-04202		

## 工事材料表

番号 NO.	名称 NAME	略図 OUTLINE	型名/規格 DESCRIPTIONS	数量 QTY	用途/備考 REMARKS
1	鳥除け BIRD DETERRENT		ZD-024-3101-3 R0HS 100-315-303-10	7	
2	六角ナット 1/2 HEX. NUT		M10 SUS304 000-166-475-10	8	
3	ハネばね SPRING WASHER		M10 SUS304 000-167-233-10	4	
4	平座金 FLAT WASHER		M10 SUS316L 000-167-416-10	4	
5	接着剤袋詰 ADHESIVE		TB5211 50G 001-517-370-00	1	

(略図の寸法は、参考値です。 DIMENSIONS IN DRAWING FOR REFERENCE ONLY.)



FURUNO ELECTRIC CO., LTD.

CN

C7283-M02-B

CODE NO.	000-033-318-00	2081-X-9405-0	1/1
TYPE	CP20-04300		

## 工事材料表

INSTALLATION MATERIALS		略 図 OUTLINE	型名/規格 DESCRIPTIONS	数 量 Q T Y	用 途 / 備 考 REMARKS
番 号 NO.	名 称 NAME				
1	モジュール (モ/コナ) MODULAR CONNECTOR	 23	MFSS68-C CODE NO. 000-166-044-10	1	
2	モジュール (モ/コナ) 用 CONNECTOR		FRU-RJ-PLUG-ASSY CODE NO. 000-192-316-10	1	
3	LANケーブル (CAT5E) CABLE ASSEMBLY	 L=30M	DT1G5E50SLABV030T CODE NO. 001-470-330-00	1	



(略図の寸法は、参考値です。 DIMENSIONS IN DRAWING FOR REFERENCE ONLY.)

FURUNO ELECTRIC CO., LTD.

C7282-M05-A

CODE NO.	000-033-319-00	2081-X-9406-0	1/1
TYPE	CP20-04310		

## 工事材料表

INSTALLATION MATERIALS		略 図 OUTLINE	型名/規格 DESCRIPTIONS	数 量 Q T Y	用 途 / 備 考 REMARKS
番 号 NO.	名 称 NAME				
1	モジュール (モ/コナ) MODULAR CONNECTOR	 23	MFSS68-C CODE NO. 000-166-044-10	1	
2	モジュール (モ/コナ) 用 CONNECTOR		FRU-RJ-PLUG-ASSY CODE NO. 000-192-316-10	1	
3	LANケーブル (CAT5E) CABLE ASSEMBLY	 L=40M	DT1G5E50SLABV040T CODE NO. 001-470-940-00	1	



(略図の寸法は、参考値です。 DIMENSIONS IN DRAWING FOR REFERENCE ONLY.)

FURUNO ELECTRIC CO., LTD.

C7282-M06-A

CODE NO.	000-033-320-00	2081-X-9407-0	1/1
TYPE	CP20-04320		

## 工事材料表

INSTALLATION MATERIALS		略図 OUTLINE		型名/規格 DESCRIPTIONS	数量 QTY	用途/備考 REMARKS
番号 NO.	名称 NAME					
1	モジュラー型コネクタ MODULAR CONNECTOR			MFSS68-C CODE NO. 000-166-044-10	1	
2	コネクタ用プラグ CONNECTOR			FRU-RJ-PLUG-ASSY CODE NO. 000-192-316-10	1	
3	LAW-7 用ケーブル CABLE ASSEMBLY			DT1G6S60SLABV0150T CODE NO. 000-470-960-00	1	





(略図の寸法は、参考値です。 DIMENSIONS IN DRAWING FOR REFERENCE ONLY.)

FURUNO ELECTRIC CO., LTD.

C7282-M07-A

CODE NO.		2081-X-9404-2	1/1
TYPE			

## 工事材料表

INSTALLATION MATERIALS		略図 OUTLINE		型名/規格 DESCRIPTIONS	数量 QTY	用途/備考 REMARKS
番号 NO.	名称 NAME					
1	LAW-7 用ケーブル CABLE ASSEMBLY			DT1G6S60SLAN0100T CODE NO. 000-521-000-00	1	選択 TO BE SELECTED
2	LAW-7 用ケーブル CABLE ASSEMBLY			DT1G6S60SLAN0160T CODE NO. 000-521-010-00	1	選択 TO BE SELECTED
3	LAW-7 用ケーブル CABLE ASSEMBLY			EDT1G6S60SLAN0161T CODE NO. 000-470-960-00	1	選択 TO BE SELECTED
4	LAW-7 用ケーブル CABLE ASSEMBLY			EDT1G6S60SLAN0180T CODE NO. 000-470-970-00	1	選択 TO BE SELECTED



(略図の寸法は、参考値です。 DIMENSIONS IN DRAWING FOR REFERENCE ONLY.)

FURUNO ELECTRIC CO., LTD.

C7282-M02-C

CODE NO.	000-033-323-00	2081-X-9408-0	1/1
TYPE	CP20-04350		

## 工事材料表

INSTALLATION MATERIALS			
番号 NO.	名称 NAME	略図 OUTLINE	用途/備考 REMARKS
1	モジュール (モ/コナ) MODULAR CONNECTOR		数量 QTY
		型名/規格 DESCRIPTIONS	1
		MF-S588-C	
		CODE NO.	
		000-166-044-10	
2	モジュール (モ/コナ) 用 CONNECTOR		数量 QTY
		型名/規格 DESCRIPTIONS	1
		FRU-RJ-PLUG-ASSY	
		CODE NO.	
		000-192-316-10	
3	LANケーブル (CAT5E) CABLE ASSEMBLY		数量 QTY
		型名/規格 DESCRIPTIONS	1
		EDT105E56SLAN8.815T	
		CODE NO.	
		000-470-990-00	



(略図の寸法は、参考値です。 DIMENSIONS IN DRAWING FOR REFERENCE ONLY.)

FURUNO ELECTRIC CO., LTD.

C7282-M08-A

CODE NO.	000-033-324-00	2081-X-9409-0	1/1
TYPE	CP20-04360		

## 工事材料表

INSTALLATION MATERIALS			
番号 NO.	名称 NAME	略図 OUTLINE	用途/備考 REMARKS
1	モジュール (モ/コナ) MODULAR CONNECTOR		数量 QTY
		型名/規格 DESCRIPTIONS	1
		MF-S588-C	
		CODE NO.	
		000-166-044-10	
2	モジュール (モ/コナ) 用 CONNECTOR		数量 QTY
		型名/規格 DESCRIPTIONS	1
		FRU-RJ-PLUG-ASSY	
		CODE NO.	
		000-192-316-10	
3	LANケーブル (CAT5E) CABLE ASSEMBLY		数量 QTY
		型名/規格 DESCRIPTIONS	1
		EDT105E56SLAN8.830T	
		CODE NO.	
		000-470-990-00	



(略図の寸法は、参考値です。 DIMENSIONS IN DRAWING FOR REFERENCE ONLY.)

FURUNO ELECTRIC CO., LTD.

C7282-M09-A

CODE NO.	000-035-430-00	2081-X-9417-0	1/1
TYPE	CP20-04370		

## 工事材料表

INSTALLATION MATERIALS		略 図 OUTLINE	型名/規格 DESCRIPTIONS	数 量 Q U A N T I T Y	用 途 / 備 考 R E M A R K S
番 号 NO.	名 称 NAME				
1	LANケーブル (CAT5E) CABLE ASSEMBLY	 L=10M	DT1CG5G0SLABVOT CODE NO. 000-195-119-10	1	
2	コネクタ (モジュラー) CONNECTOR		FRU-RJ-PLUG-ASSY CODE NO. 000-192-316-10	1	
3	コネクタ (モジュラー) MODULAR CONNECTOR	 23 12	MPSS68-C CODE NO. 000-166-044-10	1	



(略図の寸法は、参考値です。 DIMENSIONS IN DRAWING FOR REFERENCE ONLY.)

FURUNO ELECTRIC CO., LTD.

C7282-M16-A

CODE NO.	000-035-431-00	2081-X-9418-0	1/1
TYPE	CP20-04380		

## 工事材料表

INSTALLATION MATERIALS		略 図 OUTLINE	型名/規格 DESCRIPTIONS	数 量 Q U A N T I T Y	用 途 / 備 考 R E M A R K S
番 号 NO.	名 称 NAME				
1	LANケーブル (CAT5E) CABLE ASSEMBLY	 L=15M	DT1CG5G0SLABVOT CODE NO. 000-195-120-10	1	
2	コネクタ (モジュラー) CONNECTOR		FRU-RJ-PLUG-ASSY CODE NO. 000-192-316-10	1	
3	コネクタ (モジュラー) MODULAR CONNECTOR	 23 12	MPSS68-C CODE NO. 000-166-044-10	1	

(略図の寸法は、参考値です。 DIMENSIONS IN DRAWING FOR REFERENCE ONLY.)

FURUNO ELECTRIC CO., LTD.

C7282-M17-A

表1 TABLE 1

寸法区分 (mm) DIMENSION	公差 (mm) TOLERANCE
L ≤ 50	±1.5
50 < L ≤ 100	±2.5
100 < L ≤ 500	±3

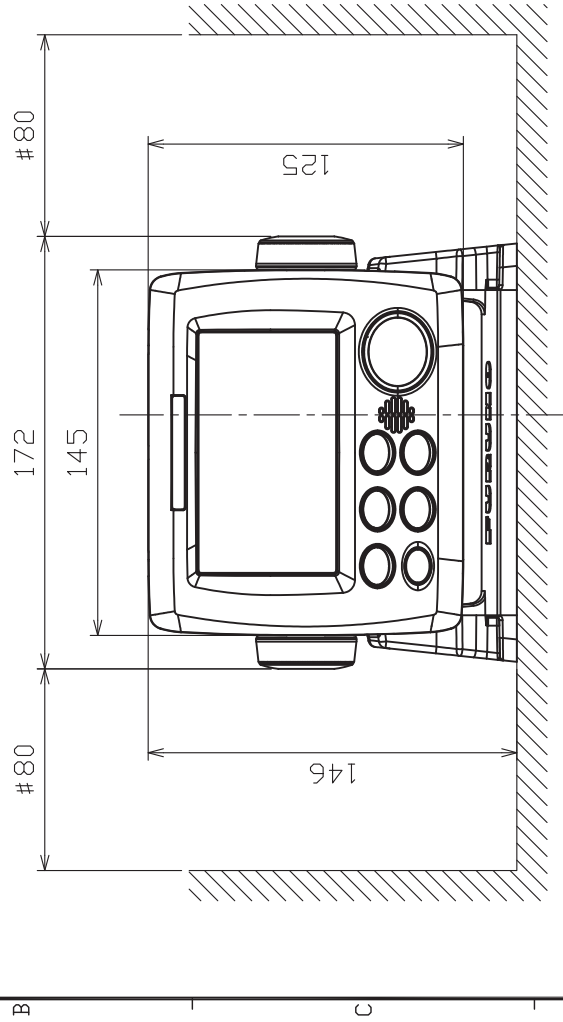
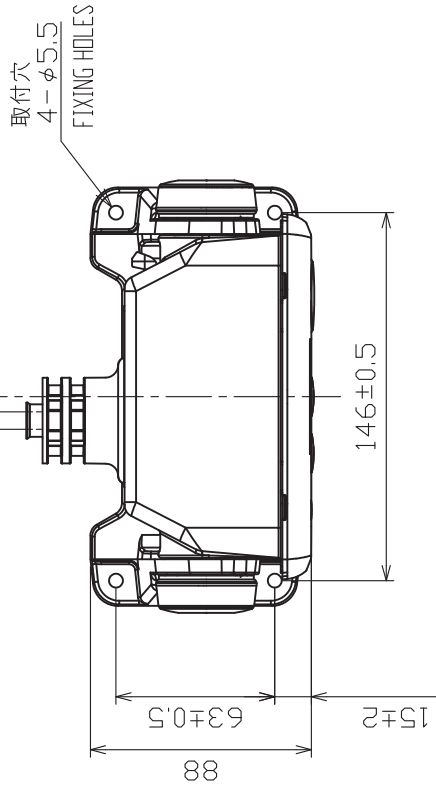
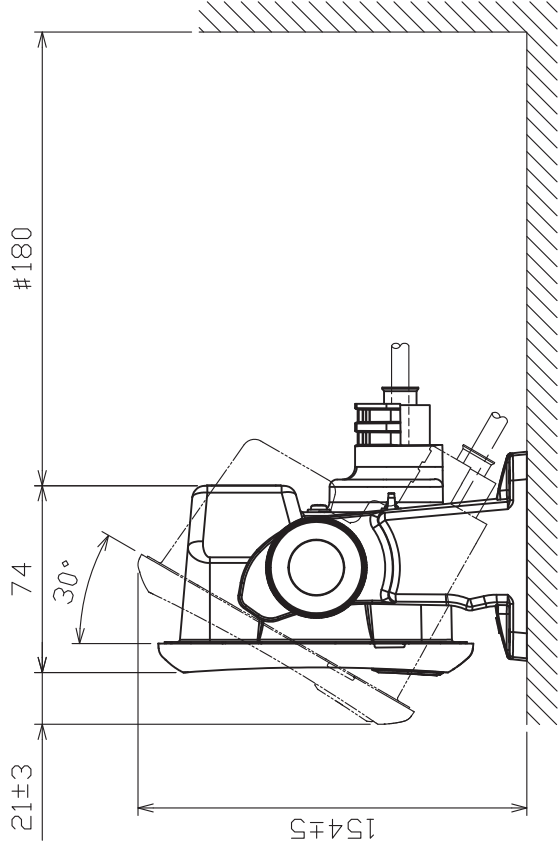
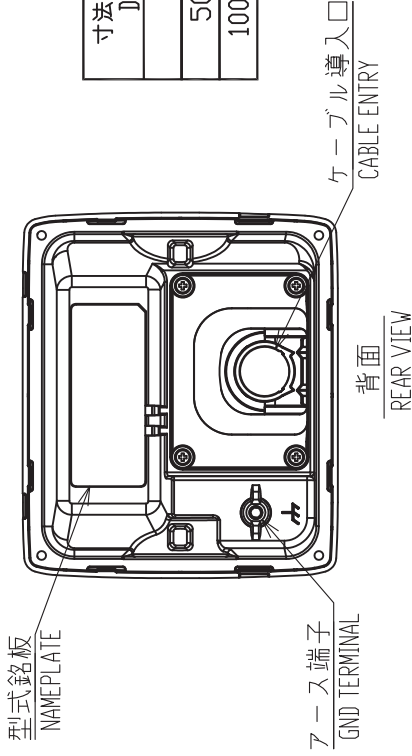

注 記

- 1) 指定外寸法公差は表 1 による。
- 2) # 印寸法は、最小サービスクリアランスとする。
- 3) 取付用ネジはトラスター呼び径5×20を使用のこと。

NOTE

1. TABLE 1 INDICATES TOLERANCE OF DIMENSIONS WHICH IS NOT SPECIFIED.
2. # MINIMUM SERVICE CLEARANCE.
3. USE TAPPING SCREWS φ5×20 FOR FIXING THE UNIT.

DRAWN	26/Dec/2017	I.YAMASAKI	TITLE	SC-702
CHECKED	26/Dec/2017	H.MAKI	名称	表示部 (卓上装備)
APPROVED	27/Dec/2017	H.MAKI	外寸図	
SCALE	1/3	MASS 0.70 kg 質量はケーブルを含みません。 MASS DOES NOT INCLUDE CABLE.	NAME	DISPLAY UNIT (TABLETOP MOUNT)
FIG.No.	C7282-601-B	REF.No.	20-037-200G-3	OUTLINE DRAWING

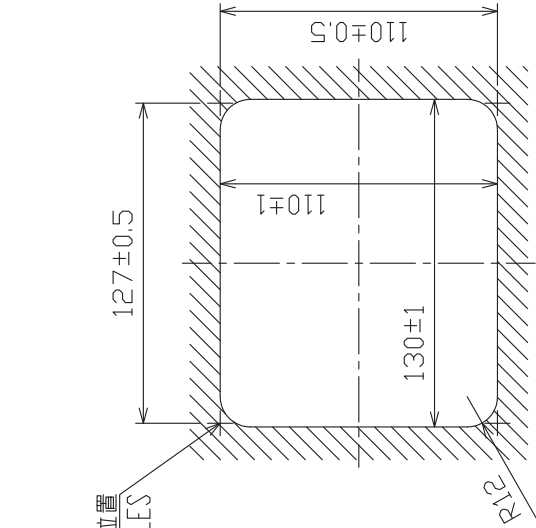

取付穴寸法  
CUTOUT DIMENSIONS



表1 TABLE 1

寸法区分 (mm) DIMENSION	公差 (mm) TOLERANCE
L ≤ 50	±1.5
50 < L ≤ 100	±2.5
100 < L ≤ 500	±3

4-取付穴位置  
PILLOT HOLES

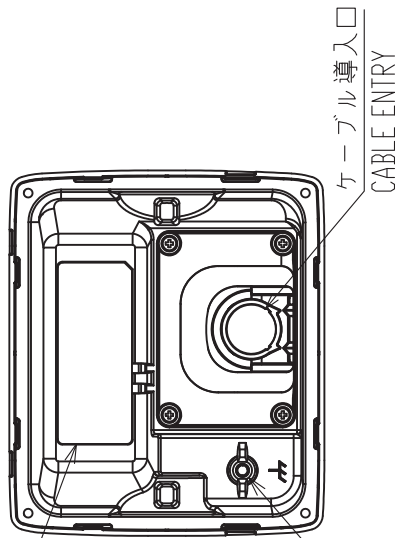
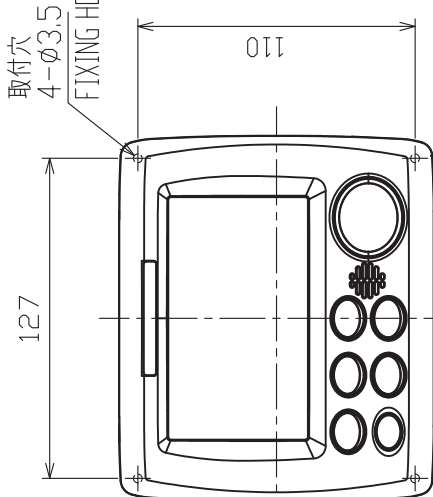
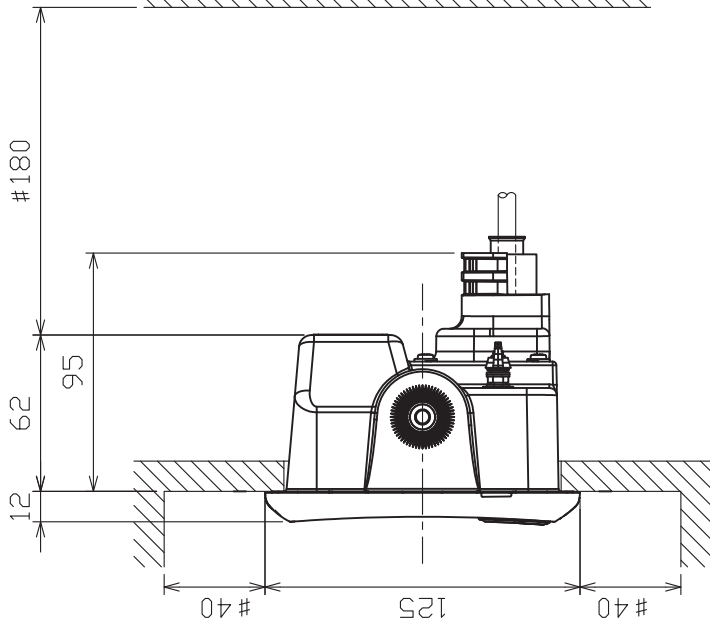

注記

- 1) 指定外寸法公差は表1による。
- 2) #印寸法は、最小サービス空間寸法とする。
- 3) 取付用ネジはナベタツピネジ呼び径3×20を使用のこと。

NOTE

1. TABLE 1 INDICATES TOLERANCE OF DIMENSIONS WHICH IS NOT SPECIFIED.
2. # MINIMUM SERVICE CLEARANCE.
3. USE PAN-HEAD TAPPING SCREWS φ3×20 FOR FIXING THE UNIT.

DRAWN	26/Dec/2017	I. YAMASAKI	TITLE	SC-702
CHECKED	26/Dec/2017	H. MAKI	名称	表示部 (埋込装備)
APPROVED	27/Dec/2017	H. MAKI	外寸図	
SCALE	1/3	質量 0.60 kg 質量はケーブルを含まず。 MASS DOES NOT INCLUDE CABLE.	NAME	DISPLAY UNIT (FLUSH MOUNT)
JWG.No.	C7282-602-B	REF.No.	20-037-201G-3	OUTLINE DRAWING





表1 TABLE 1

寸法区分 (mm) DIMENSION	公差 (mm) TOLERANCE
L ≤ 50	±1.5
50 < L ≤ 100	±2.5
100 < L ≤ 500	±3



取付穴  
4-φ5  
FIXING HOLES

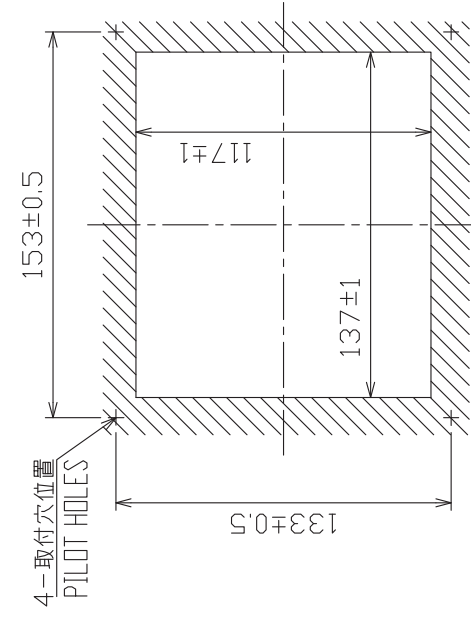
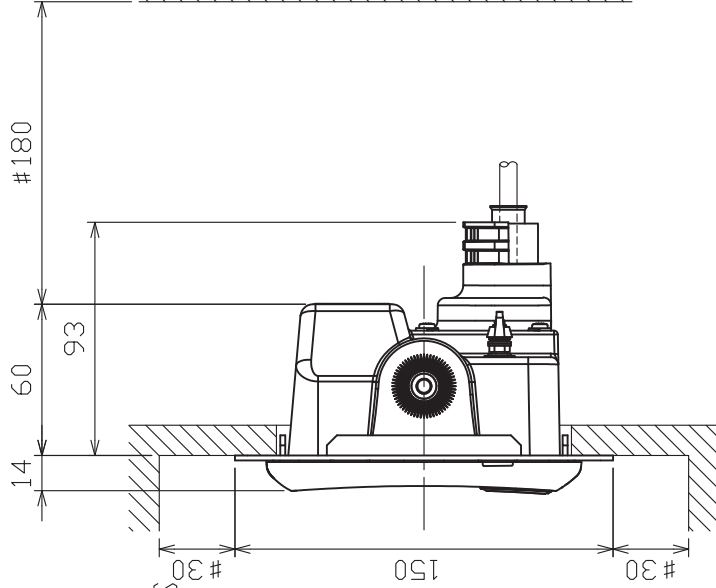
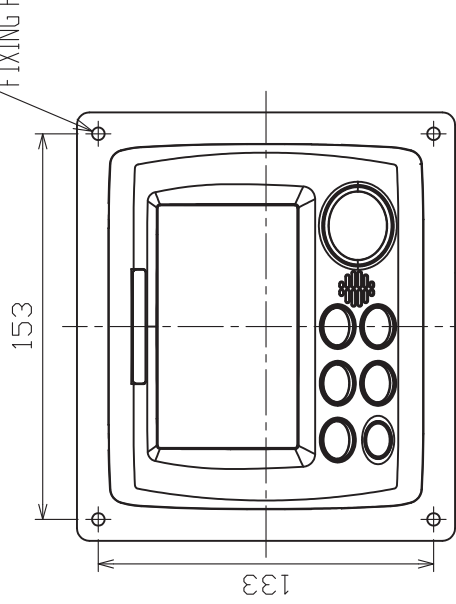

取付穴寸法図  
CUTOUT DIMENSIONS

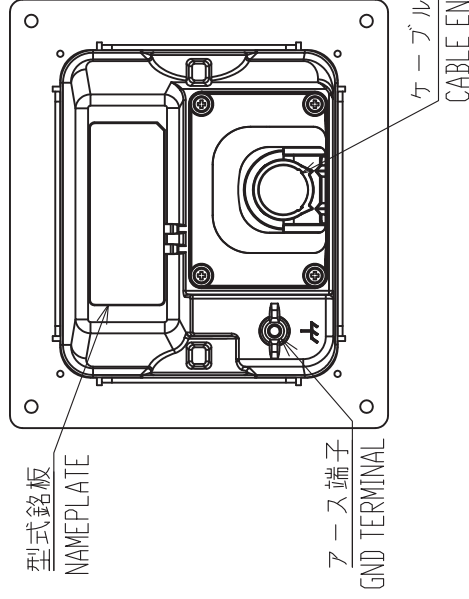

注 記

- 1) 指定外寸法公差は表 1 による。
- 2) # 印寸法は、最小サービス空間寸法とする。
- 3) 取付用ネジはトラススタッピネジ呼び径 4 × 1.6 を使用のこと。

NOTE

1. TABLE 1 INDICATES TOLERANCE OF DIMENSIONS WHICH IS NOT SPECIFIED.
2. # MINIMUM SERVICE CLEARANCE.
3. USE TAPPING SCREWS φ4x1.6 FOR FIXING THE UNIT.

DRAWN	26/Dec/2017	I. YAMASAKI	TITLE	SC-702
CHECKED	26/Dec/2017	H. MAKI	名称	表示部 (パネル装備)
APPROVED	27/Dec/2017	H. MAKI	外寸図	
SCALE	1/3	質量 0.65 kg	NAME	DISPLAY UNIT (PANEL MOUNT)
IMG.No.	C7282-603-B	質量はケーブルを含みません。 MASS DOES NOT INCLUDE CABLE.	OUTLINE DRAWING	
		REF.No.	20-037-202G-3	

表1 TABLE 1

寸法区分 (mm) DIMENSION	公差 (mm) TOLERANCE
L ≤ 50	±1.5
50 < L ≤ 100	±2.5
100 < L ≤ 500	±3

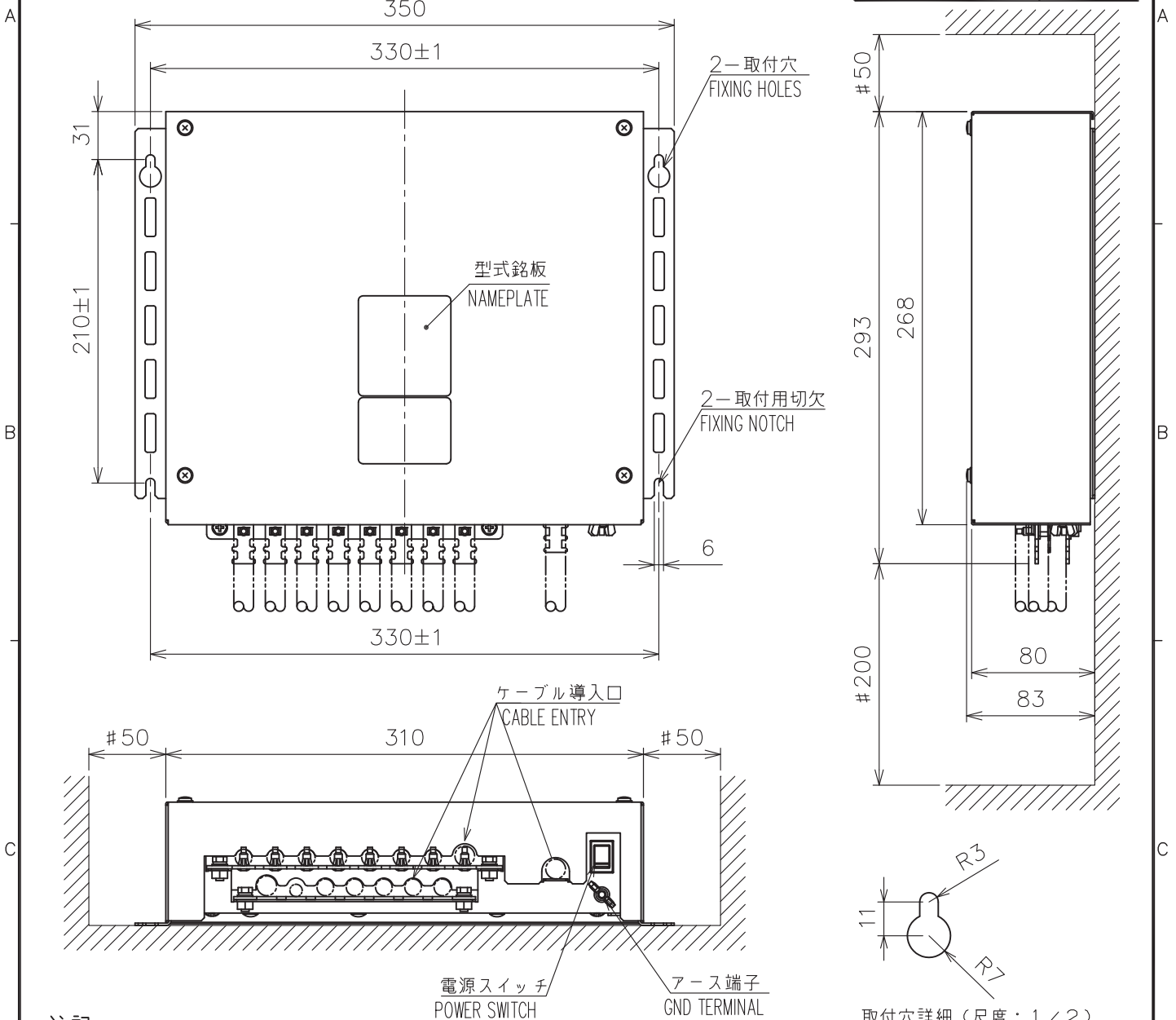

注記

- 1) 指定外の寸法公差は表1による。
- 2) #印寸法は最小サービス空間寸法とする。
- 3) 取付用ネジはタッピンネジM5×20、またはM5ボルトを使用のこと。

NOTE

1. TABLE 1 INDICATES TOLERANCE OF DIMENSIONS WHICH IS NOT SPECIFIED.
2. #: MINIMUM SERVICE CLEARANCE.
3. USE M5 BOLTS OR TAPPING SCREWS M5x20 FOR FIXING THE UNIT.

取付穴詳細 (尺度: 1/2)  
DETAIL FOR FIXING (SCALE: 1/2)

表2 TABLE 2

変換基板 LAN-CNV	質量 (kg±10%) MASS
なし -	2.9
あり YES	3.1

DRAWN	17/Jan/2017 T.YAMASAKI	TITLE	SC-701	
CHECKED	17/Jan/2017 H.MAKI	名称	接続箱	
APPROVED	17/Jan/2017 H.MAKI	SC-70/130	外寸図	
SCALE	1/4	MASS表2参照 SEE TABLE 2	NAME	JUNCTION BOX
DWG. No.	C7282-G04-C	REF. No.	20-037-100G-3	OUTLINE DRAWING

ケーブル導入可能範囲 (底面側)  
CABLE ENTRY (BOTTOM)

ケーブル導入口 (船尾側)  
CABLE ENTRY (STERN)

船首方向  
BOW



表1 TABLE 1

寸法区分 (mm) DIMENSION	公差 (mm) TOLERANCE
L ≤ 50	±1.5
50 < L ≤ 100	±2.5
100 < L ≤ 500	±3
500 < L ≤ 1000	±4

表2 TABLE 2

プラグ PLUG	交換基板 LAN-CONV	質量 MASS (kg±10%)
LAN	なし	2.8
TNC	あり	2.9

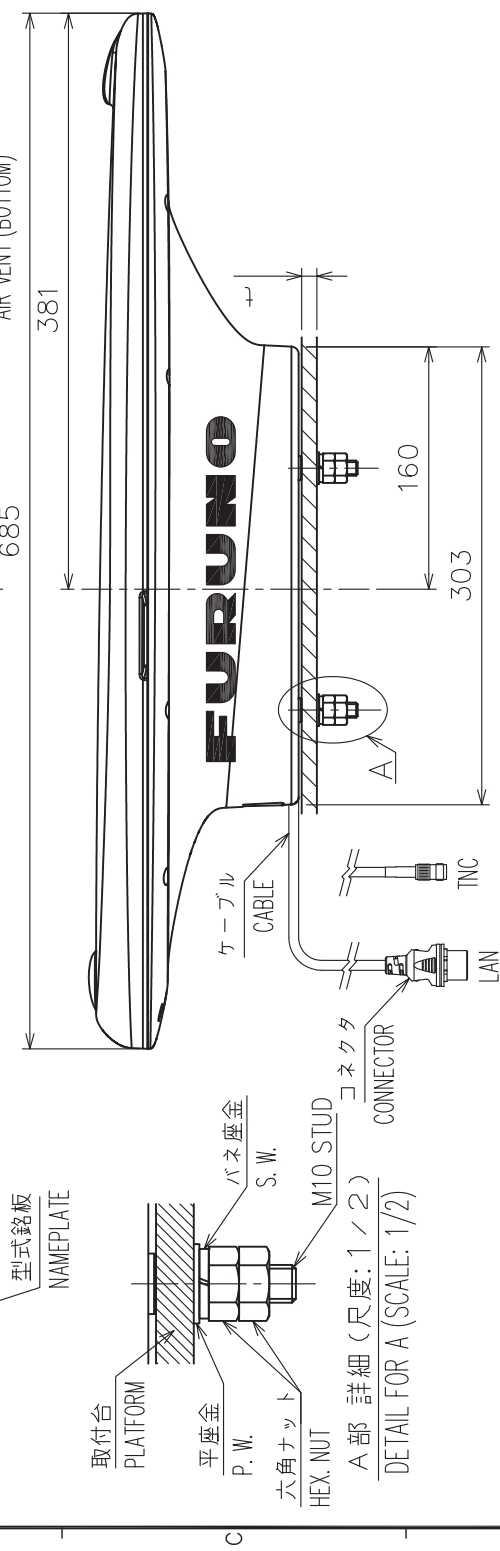
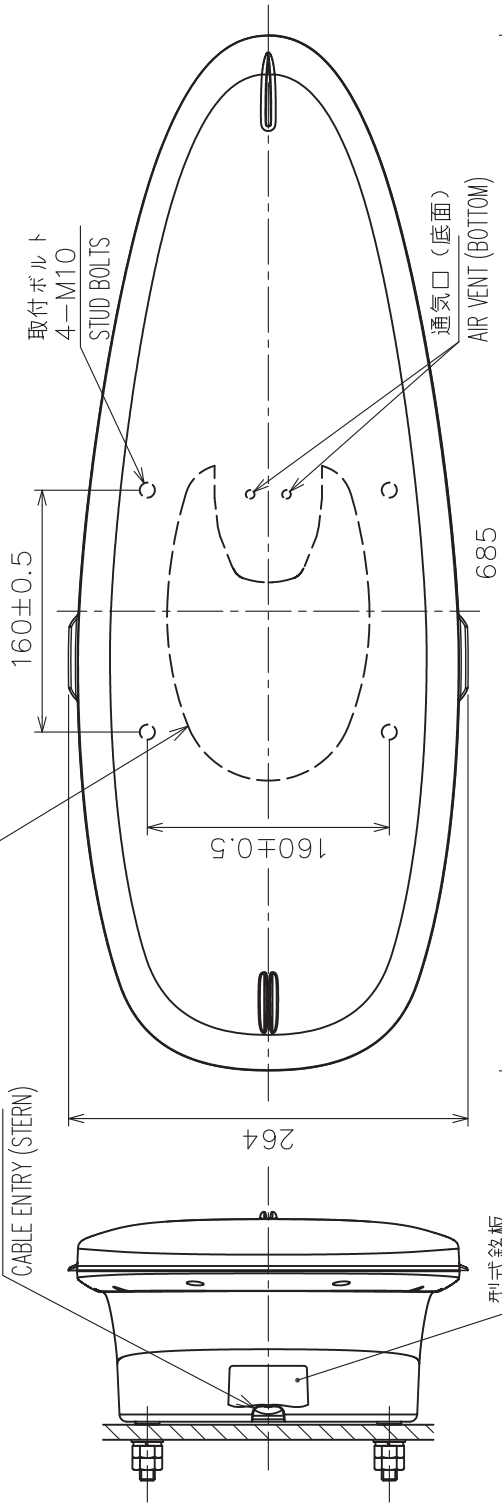
- 注 記
- 1) 指定外の寸法公差は表1による。
  - 2) 取付台の厚さ (t) は、5以上15以下とする。
- NOTE
1. TABLE 1 INDICATES TOLERANCE OF DIMENSIONS WHICH IS NOT SPECIFIED.
  2. THICKNESS OF PLATFORM (t): 5 ≤ t ≤ 15.

DRAWN	25/Jan/2018	I. YAMASAKI	TITLE	SC-703
CHECKED	25/Jan/2018	H. MAKI	各種	空中線部
APPROVED	25/Jan/2018	H. MAKI	外寸図	SC-70
SCALE	1/5	質量はケーブル (0.5m) を含む。 MASS INCLUDES 0.5m CABLE.	NAME	ANTENNA UNIT
DWG.No.	C7282-G05-C	REF.No.	20-037-300G-3	OUTLINE DRAWING



表1 TABLE 1  
A部 詳細 (尺度 1:2)  
DETAIL OF A (SCALE:1/2)

寸法区分 (mm) DIMENSION	公差 (mm) TOLERANCE
$L \leq 50$	$\pm 1.5$
$50 < L \leq 100$	$\pm 2.5$
$100 < L \leq 500$	$\pm 3$
$500 < L \leq 1000$	$\pm 4$
$1000 < L \leq 2000$	$\pm 5$

プラグ PLUG	交換基板 LAN-CONV	質量 MASS (kg±10%)
なし	-	7.1
TNC	あり	7.2

表2 TABLE 2

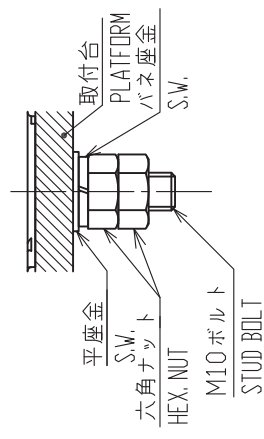
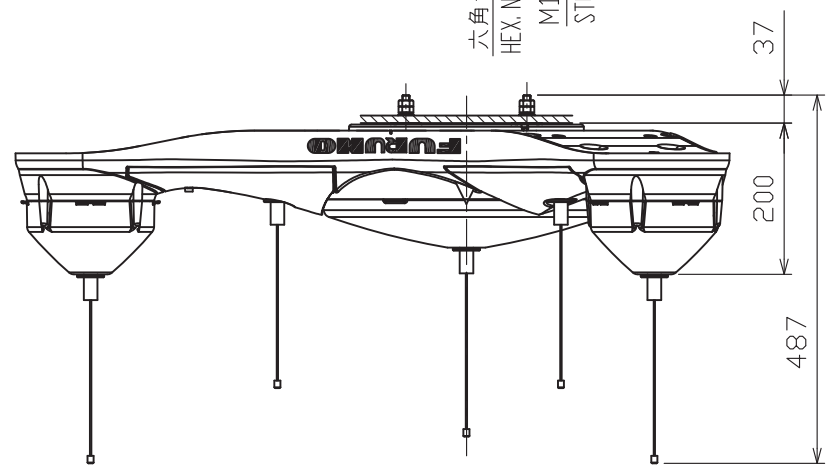
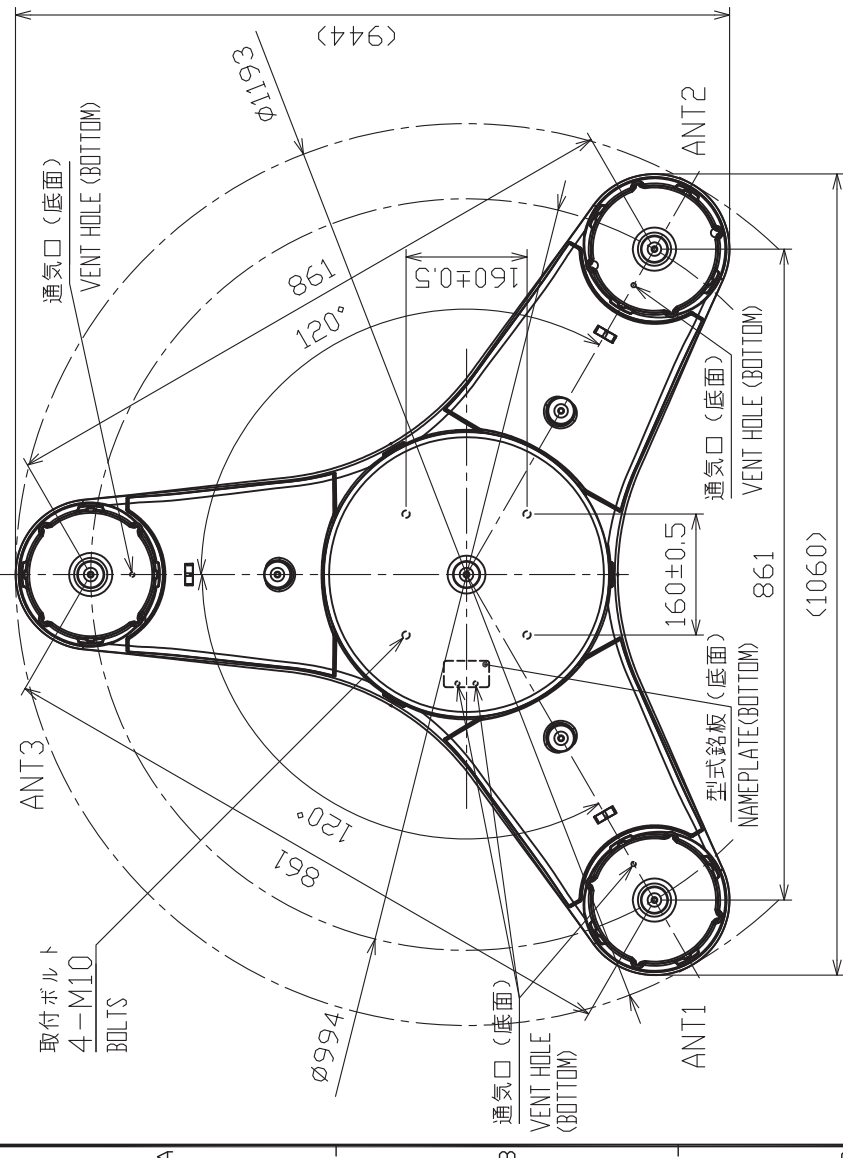
- 注記 1) 指定外の寸法公差は表1による。  
 2) 取付台の厚さ (t) は、5以上15以下とする。  
 3) 取付面は平坦であること。

- NOTE 1. TABLE 1 INDICATES TOLERANCE OF DIMENSIONS WHICH IS NOT SPECIFIED.  
 2. THICKNESS OF PLATFORM (t)  $5 \leq t \leq 15$ .  
 3. PLATFORM SHOULD BE FLAT.

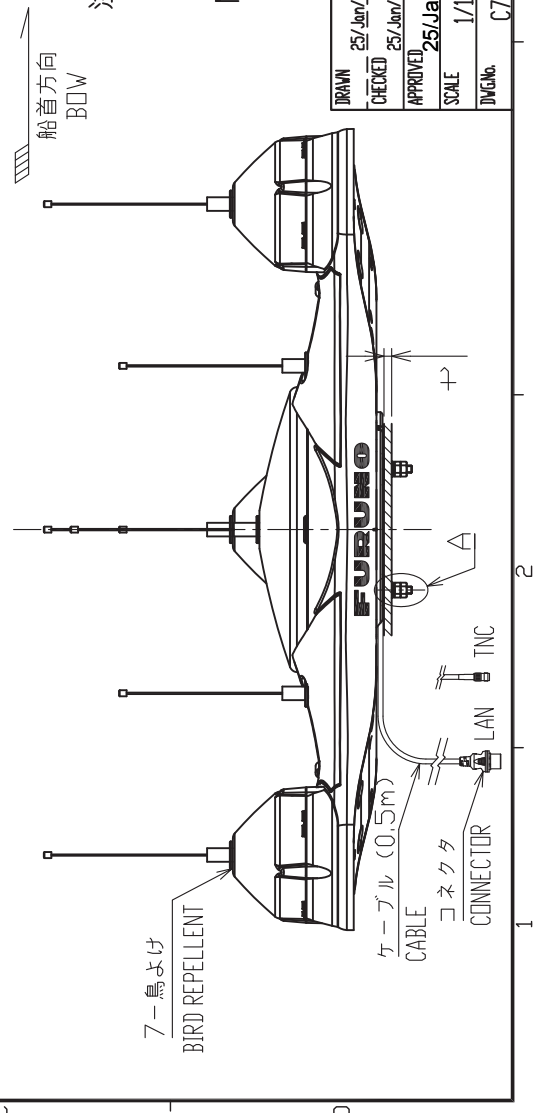

DRAWN	25/Jan/2018	I. YAMASAKI	TITLE	SC-1303
CHECKED	25/Jan/2018	H. MAKI	名称	空中線部
APPROVED	25/Jan/2018	H. MAKI		外寸図
SCALE	1/10	質量は原金・ナットを含まず MASS DOES NOT INCLUDE WASHER/NUT.	WME	ANTENNA UNIT
FIG.No.	C7283-601-D	REF.No.	20-037-350G-3	OUTLINE DRAWING

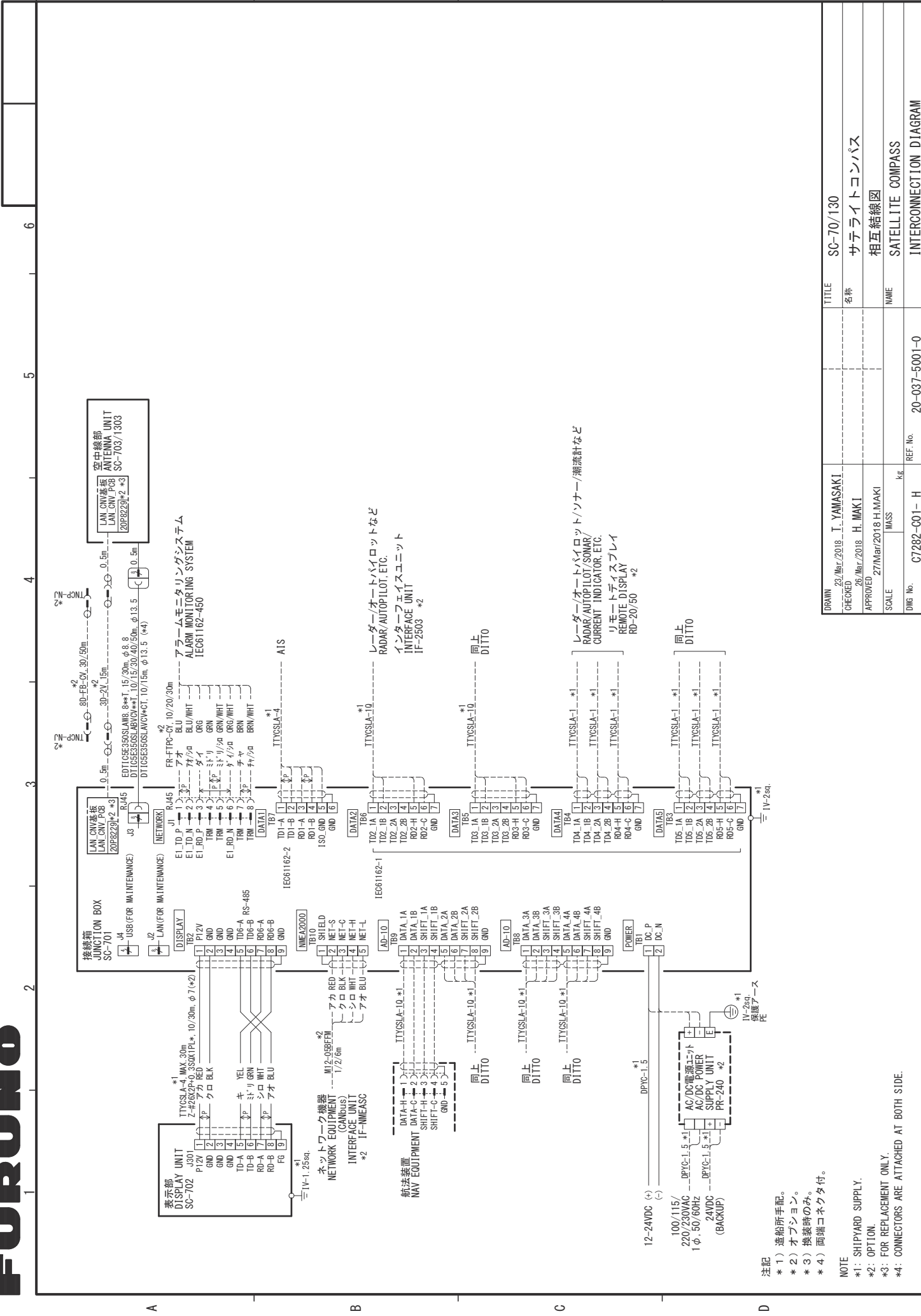

DRAWN	23/Mar./2018	I. YAMASAKI	TITLE	SC-70/130
CHECKED	26/Mar./2018	H. MAKI	名称	サテライトコンパス
APPROVED	27/Mar./2018	H. MAKI	相互結線図	相互結線図
SCALE		1/25	NAME	SATELLITE COMPASS
DWG No.	C7282-001-H	REF. No.	20-037-5001-0	INTERCONNECTION DIAGRAM

- 注記
- \*1) 造船所手配。
  - \*2) オプション。
  - \*3) 換装時のみ。
  - \*4) 両端コネクタ付。
- NOTE
- \*1: SHIPYARD SUPPLY.
  - \*2: OPTION.
  - \*3: FOR REPLACEMENT ONLY.
  - \*4: CONNECTORS ARE ATTACHED AT BOTH SIDE.

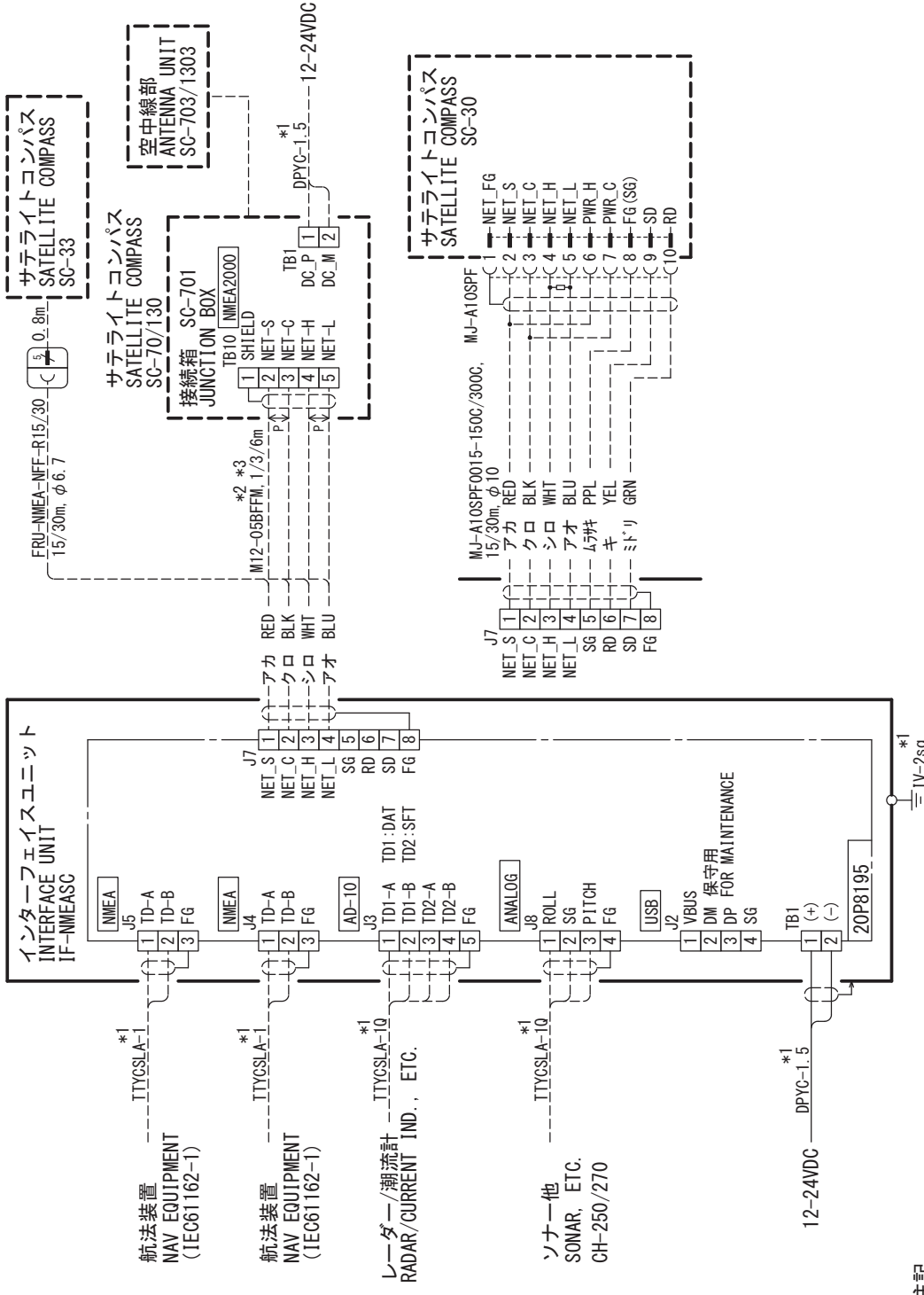

**注記**  
 \* 1) 造船所手配。  
 \* 2) オプション。  
 \* 3) コネクタを取り外して接続する。

**NOTE**  
 \*1: SHIPYARD SUPPLY.  
 \*2: OPTION.  
 \*3: REMOVE THE PLUG FOR FABRICATION.

DRAWN	25/Oct/2017	T. YAMASAKI	TITLE	IF-NMEASC
CHECKED	25/Oct/2017	H. MAKI	名称	インターフェイスユニット
APPROVED	27/Oct/2017	H. MAKI	相互結線図	
SCALE	MASS	kg	INTERFACE UNIT	
DWG. No.	C7265-C02-B	REF. No.	INTERCONNECTION DIAGRAM	

# INDEX

---

## A

Alerts .....	2-15
acknowledge .....	2-16
alert codes .....	AP-4
alert list .....	AP-4
buzzer on/off .....	2-16
list .....	2-17
log .....	2-18

## B

Background color .....	2-20
Backup user settings .....	3-3
Basic troubleshooting .....	3-2

## C

Controls .....	2-1
----------------	-----

## D

Data schematics .....	AP-12
Data sentences .....	AP-11
Data transmission .....	AP-11
Date .....	2-22
DGPS/SBAS settings .....	2-25
Diagnostics .....	3-5
automatic test .....	3-7
keyboard test .....	3-6
LCD test .....	3-6
memory test .....	3-5
sound test .....	3-7
Display	
change mode .....	2-5
GPS mode .....	2-7
icons .....	2-6
indications .....	2-6
navigational data .....	2-15
ROTI mode .....	2-13
SPD mode .....	2-14
THD mode .....	2-10
Display overview .....	2-5

## E

EGNOS .....	AP-10
-------------	-------

## F

Fuse .....	3-1
------------	-----

## G

GAGAN .....	AP-10
Geodetic chart codes .....	AP-9
Geodetic data settings .....	2-22
GNSS settings .....	2-24

## I

I/O settings	
data logs .....	2-30
data sources .....	2-29
HDG output restart .....	2-32

LAN data output .....	2-28
serial data output .....	2-27

## Initial Settings

offsets .....	1-27
OS dimensions .....	1-26

Input sentences .....

AP-12

## Installation

display unit - bulkhead .....	1-8
display unit - desktop .....	1-8
display unit - flushmount .....	1-9
optional waterproofing kit .....	1-22
RD-50 remote display unit .....	1-10
SC-1303 antenna unit .....	1-5
SC-701 junction box .....	1-7
SC-702 display unit .....	1-8
SC-703 antenna unit .....	1-3
waterproofing connections .....	1-14

## Installation considerations

SC-701 junction box .....	1-7
SC-702 display unit .....	1-8
SC-703/SC-1303 antenna units .....	1-1

## J

JIS cable guide .....	AP-26
-----------------------	-------

## L

Language .....	2-23
----------------	------

## M

Maintenance .....	3-1
fuse .....	3-1
Menu tree .....	AP-1
MSAS .....	AP-10

## O

Output sentences .....	AP-14
------------------------	-------

## R

RAIM	
setup .....	2-26

## S

SBAS providers .....	AP-10
SBAS search .....	2-25
Smoothing .....	2-21

## T

Time .....	2-22
Transmission intervals .....	AP-11
Trip meter .....	2-22

## U

Units of measurement .....	2-20
User settings	
backup .....	3-3

## W

WAAS .....	AP-10
Wiring .....	1-11

## INDEX

cable fabrication .....	1-12
display unit .....	1-20
junction box .....	1-17



## Declaration of Conformity



# 0560

We **FURUNO ELECTRIC CO., LTD.**

(Manufacturer)

9-52 Ashihara-Cho, Nishinomiya City, 662-8580, Hyogo, Japan

(Address)

declare under our sole responsibility that the product

**SATELLITE COMPASS SC-70 and SC-130**

(Model name, type number)

to which this declaration relates conforms to the following standard(s) or normative document(s)

IMO Resolution A.526(13)	ISO 20672 Ed.1.0: 2007
IMO Resolution A.694(17)	ISO 22090-3 Ed.2.0: 2014
IMO Resolution MSC.112(73)	IEC 60945 Ed.4.0: 2002
IMO Resolution MSC.116(73)	IEC 61108-1 Ed.2.0: 2003
IMO Resolution MSC.191(79)	IEC 61162-1 Ed.5.0: 2016
IMO Resolution MSC.302(87)	IEC 61162-2 Ed.1.0: 1998
2000 HSC Code 13	IEC 61162-450 Ed.1.0: 2011
	IEC 62288 Ed.2.0: 2014

(title and/or number and date of issue of the standard(s) or other normative document(s))

For assessment, see

- EC type examination (Module B) certificate No. MEDB00001BW, MEDB00001BX and MEDB00001BY issued by DNV GL (0575), Norway.
- Product Quality System (Module D) certificate No. P 112 issued by Telefication, The Netherlands.

This declaration is issued according to the Directive 2014/90/EU of the European Parliament and of the Council on marine equipment, and the amending Directive (EU) 2017/306.

On behalf of Furuno Electric Co., Ltd.

Nishinomiya City, Japan  
September 8, 2017

(Place and date of issue)

Yoshitaka Shogaki  
Department General Manager  
Quality Assurance Department

(name and signature or equivalent marking of authorized person)